

| 1 | 2 | | 3 | | 4 | | 5 | | 6 | | | 7 | | 8 | |
|----------------------|---------------------------------|---------------------------------|----------------------------------|--------------|--|--------------------------------|--|---|----------|----------|-----------------|-------------|--------------------|----------------|-----------------|
| INPUT FLANGE DETAILS | | | | | | | MOUNTING HOLES - BOLT CIRCLE (OFF CENTRES) | | | | | | | | |
| INPUT FLANGE | FLANGE O/DIA. + THICKNESS | SHAFT DIA. | RECESS DIA. | RECESS DEPTH | HOLE DETAILS (45° OFF CENTRES) | KEY DETAILS | ISO 5211 / MSS SP-101 MOUNTING OPTION | HOLE DETAILS (22.5° OFF CENTRES) | STANDARD | MIN BORE | SQ KEY MAX BORE | SQ KEY SIZE | RECT. KEY MAX BORE | RECT. KEY SIZE | SQ BORE MAX |
| ISO F25 | Ø300 x 20 (Ø11.81" x 0.787") | Ø50.00-0.05 (Ø1.969"-0.002") | Ø200.10+0.10 (Ø7.878"+0.004") | 5 (0.20") | 8 x Ø16.5 ON Ø254.0 P.C. (8 x Ø0.65" ON Ø10.00" P.C.) | 14x9x55 (0.55"x0.35"x2.17") | ISO F30* | 8 x M20 x 30 (1.18") DEEP ON Ø298.0 (Ø11.73") P.C. | BS4235 | - | - | - | 157 | 40 x 22 | □ 122.9 (4.84") |
| FA25 | | | | | | | | | BS46 | - | 5.625" | 1.1/2" SQ. | 6.00" | 1.1/2" x 1" | |
| | ANSI B17.1 | - | 5.625" | 1.1/2" SQ. | 6.00" | 1.1/2" x 1" | | | | | | | | | |
| | DIN 6885 | - | - | - | 157 | 40 x 22 | | | | | | | | | |

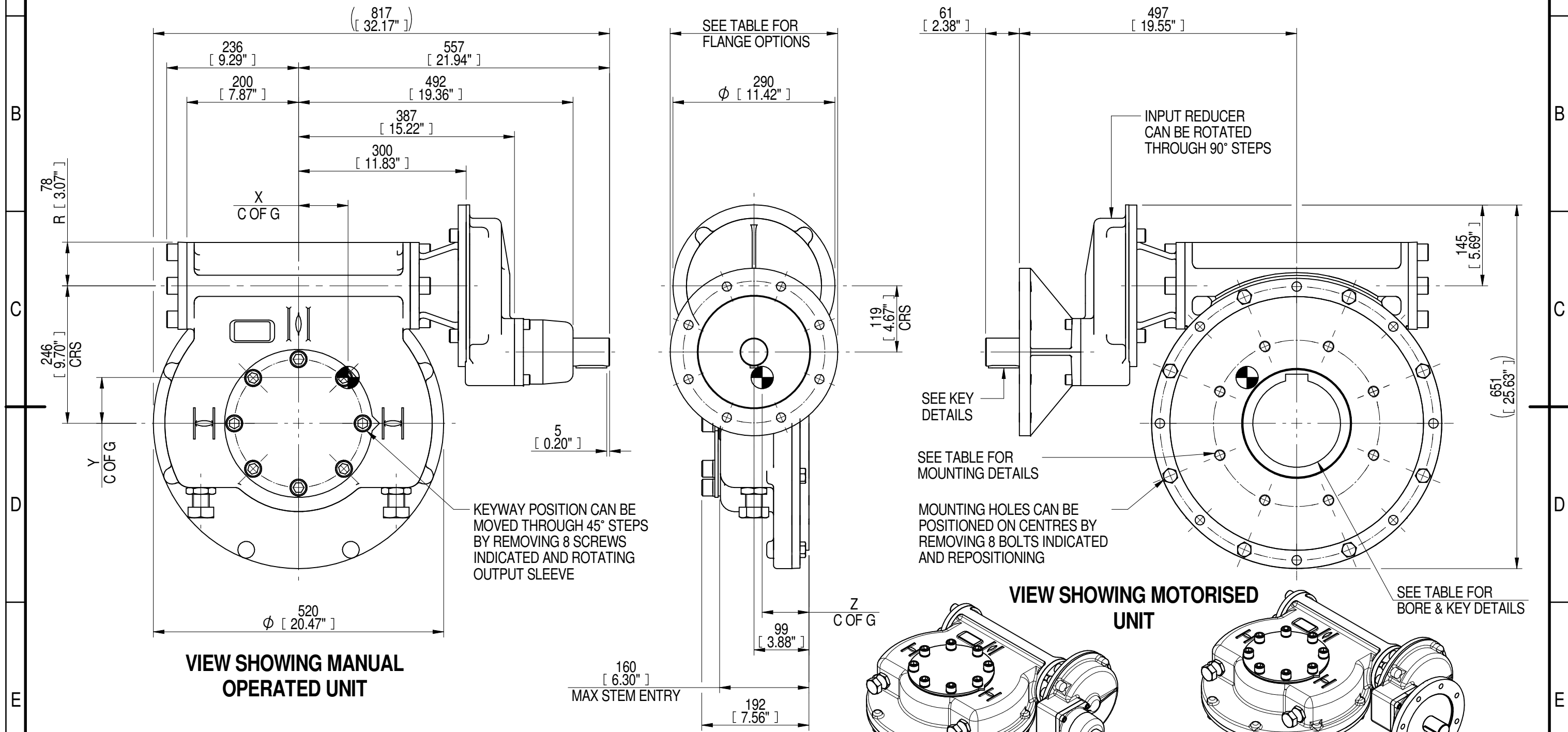

PLAN VIEW OF GEARBOX IN CLOSED POSITION SHOWING STANDARD KEYWAY POSITIONS. ALTERNATIVES AVAILABLE ON REQUEST

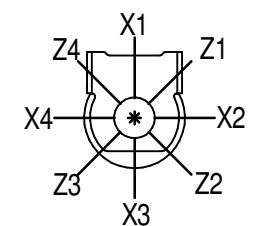

- NOTES:
- * THREAD DEPTH DOES NOT MATCH ISO STANDARD
 - CENTRE OF GRAVITY POSITION IS INDICATIVE FOR STANDARD BUILD WHEN IN POSITION SHOWN

| 360 | 90 | 142 | 185 | 26031 | 183 | 89 | 83 | 84 |
|-------------|----------------|------------|-------------|-----------------|----------------|-------------------|----|----|
| 240 | 60 | 95 | 185 | 26031 | 274 | 89 | 83 | 84 |
| 180 | 45 | 71 | 184 | 26031 | 367 | 89 | 83 | 84 |
| 120 | 30 | 48 | 185 | 26031 | 542 | 89 | 82 | 84 |
| RATIO | TURNS TO CLOSE | M.A. ± 10% | WEIGHT (Kg) | MAX OUTPUT (Nm) | MAX INPUT (Nm) | X | Y | Z |
| DESCRIPTION | | | | TORQUE | | CENTRE OF GRAVITY | | |

AS PART OF CONTINUOUS PRODUCT DEVELOPMENT, ALL DETAILS SUBJECT TO CHANGE WITHOUT PRIOR NOTICE. FOR UP TO DATE DETAILS PLEASE VISIT www.rotork.com

| | | | |
|--|---|--|------------|
| | Document Type PUBLICITY | Title IW/MOW8 QUARTER TURN GEARBOX, 120/180/240/360 : 1, MANUAL, F25/ FA25 INPUT : F30/ FA30 OUTPUT Drawing Number PUB-IW8FBIRS-F25-F30 | Iss. 01 |
| | Dimensions in mm | | |
| LEEDS - UK www.rotork.com | This drawing is confidential and is the property of Rotork Gears and must not be reproduced either wholly or partly. All rights in respect of patents, designs and copyrights are reserved. ©2016 | | |
| Sheet 1 of 1 | | Size A3 | |