

INPUT FLANGE DETAILS							MOUNTING HOLES - BOLT CIRCLE (OFF CENTRES)								
INPUT FLANGE	FLANGE O/DIA. + THICKNESS	SHAFT DIA.	RECESS DIA.	RECESS DEPTH	HOLE DETAILS (45° OFF CENTRES)	KEY DETAILS	ISO 5211 / MSS SP-101 MOUNTING OPTION	HOLE DETAILS (22.5° OFF CENTRES)	STANDARD	MIN BORE	SQ KEY MAX BORE	SQ KEY SIZE	RECT. KEY MAX BORE	RECT. KEY SIZE	SQ BORE MAX
ISO F25	Ø300 x 20 (Ø11.81" x 0.787")	Ø50.00-0.05 (Ø1.969"-0.002")	Ø200.10+0.10 (Ø7.878"+0.004")	5 (0.20")	8 x Ø16.5 ON Ø254.0 P.C. (8 x Ø0.65" ON Ø10.00" P.C.)	14x9x55 (0.55"x0.35"x2.17")	ISO F25*	8 x M16 x 24 (0.94") DEEP ON Ø254.0 (Ø10.00") P.C.	BS4235	-	-	-	157	40 x 22	□ 122.9 (4.84")
FA25							8 x 5/8" UNC x 24 (0.94") DEEP ON Ø254.0 (Ø10.00") P.C.	ANSI B17.1	-	5.625"	1.1/2" SQ.	6.00"	1.1/2" x 1"		
								DIN 6885	-	-	-	157	40 x 22		

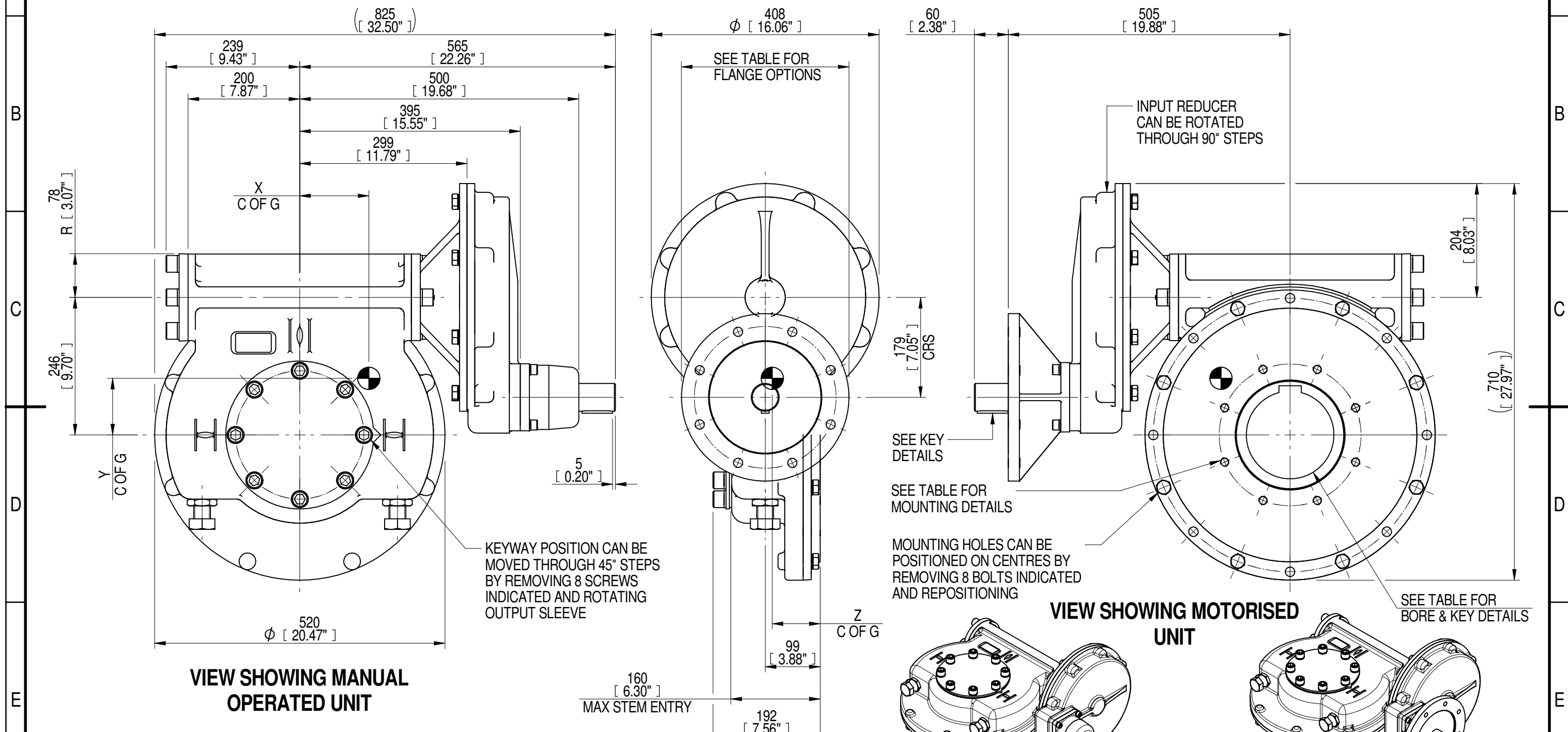

PLAN VIEW OF GEARBOX IN CLOSED POSITION SHOWING STANDARD KEYWAY POSITIONS. ALTERNATIVES AVAILABLE ON REQUEST

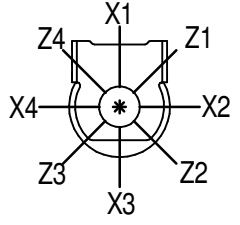

- NOTES:
- * THREAD DEPTH DOES NOT MATCH ISO STANDARD
 - CENTRE OF GRAVITY POSITION IS INDICATIVE FOR STANDARD BUILD WHEN IN POSITION SHOWN

720	180	285	220	37000	130	126	103	87
540	135	214	217	37000	173	124	102	86
480	120	189	217	37000	196	124	101	86
RATIO	TURNS TO CLOSE	M.A. ± 10%	WEIGHT (Kg)	MAX OUTPUT (Nm)	MAX INPUT (Nm)	X	Y	Z
DESCRIPTION				TORQUE		CENTRE OF GRAVITY		

AS PART OF CONTINUOUS PRODUCT DEVELOPMENT, ALL DETAILS SUBJECT TO CHANGE WITHOUT PRIOR NOTICE. FOR UP TO DATE DETAILS PLEASE VISIT www.rotork.com

rotork Gears
LEEDS - UK
www.rotork.com

This drawing is confidential and is the property of Rotork Gears and must not be reproduced either wholly or partly. All rights in respect of patents, designs and copyrights are reserved. ©2016

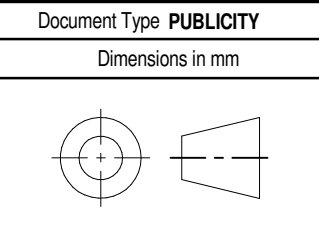

Title IW/MOW82 QUARTER TURN GEARBOX, 480/540/720 : 1, MANUAL, F25/ FA25 INPUT : F25/ FA25 OUTPUT	
Drawing Number PUB-IW82FBIRL-F25-F25	Iss. 01
Sheet 1 of 1	Size A3