

INPUT FLANGE DETAILS							MOUNTING HOLES - BOLT CIRCLE (OFF CENTRES)								
INPUT FLANGE	FLANGE O/DIA. + THICKNESS	SHAFT DIA.	RECESS DIA.	RECESS DEPTH	HOLE DETAILS (45° OFF CENTRES)	KEY DETAILS	ISO 5211 / MSS SP-101 MOUNTING OPTION	HOLE DETAILS (22.5° OFF CENTRES)	STANDARD	MIN BORE	SQ KEY MAX BORE	SQ KEY SIZE	RECT. KEY MAX BORE	RECT. KEY SIZE	SQ BORE MAX
ISO F25	Ø300 x 20 (Ø11.81" x 0.787")	Ø50.00-0.05 (Ø1.969"-0.002")	Ø200.10+0.10 (Ø7.878"+0.004")	5 (0.20")	8 x Ø16.5 ON Ø254.0 P.C. (8 x Ø0.65" ON Ø10.00" P.C.)	14x9x55 (0.55"x0.35"x2.17")	ISO F40*	8 x M36 x 36 (1.42") DEEP ON Ø406.0 (Ø15.98") P.C.	BS4235	-	-	-	157	40 x 22	□ 122.9 (4.84")
FA25							8 x 1.25" UNC x 36 (1.42") DEEP ON Ø406.4 (Ø16.00") P.C.	ANSI B17.1	-	5.625"	1.1/2" SQ.	6.00"	1.1/2" x 1"		
							DIN 6885	-	-	-	-	157	40 x 22		

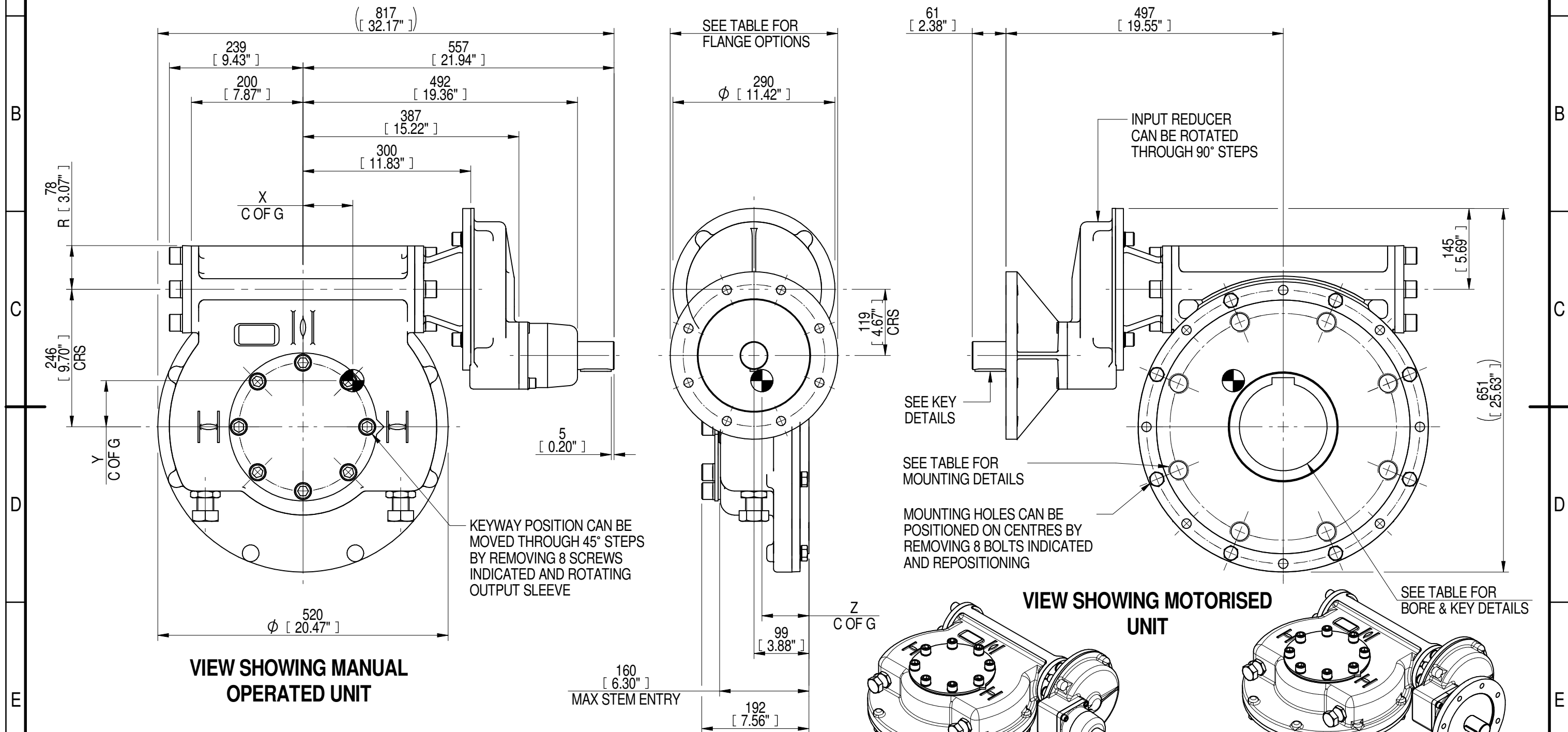

PLAN VIEW OF GEARBOX IN CLOSED POSITION SHOWING STANDARD KEYWAY POSITIONS. ALTERNATIVES AVAILABLE ON REQUEST



NOTES:
 1. * THREAD DEPTH DOES NOT MATCH ISO STANDARD
 2. CENTRE OF GRAVITY POSITION IS INDICATIVE FOR STANDARD BUILD WHEN IN POSITION SHOWN

RATIO	TURNS TO CLOSE	M.A. ± 10%	WEIGHT (Kg)	MAX OUTPUT (Nm)	MAX INPUT (Nm)	X	Y	Z
DESCRIPTION			TORQUE		CENTRE OF GRAVITY			
360	90	142	184	37000	261	90	84	84
240	60	95	184	37000	389	89	84	84
180	45	71	184	37000	521	89	83	84
120	30	48	184	37000	771	89	83	84

AS PART OF CONTINUOUS PRODUCT DEVELOPMENT, ALL DETAILS SUBJECT TO CHANGE WITHOUT PRIOR NOTICE. FOR UP TO DATE DETAILS PLEASE VISIT www.rotork.com

<p>LEEDS - UK www.rotork.com</p>	<p>This drawing is confidential and is the property of Rotork Gears and must not be reproduced either wholly or partly. All rights in respect of patents, designs and copyrights are reserved. ©2016</p>	<p>Document Type PUBLICITY</p>	<p>Title IW/MOW82 QUARTER TURN GEARBOX, 120/180/240/360 : 1, MANUAL, F25/ FA25 INPUT : F40/ FA40 OUTPUT</p>
		<p>Dimensions in mm</p>	
<p>Sheet 1 of 1 Size A3</p>		<p>Iss. 01</p>	