

INPUT FLANGE DETAILS							MOUNTING HOLES - BOLT CIRCLE (OFF CENTRES)								
INPUT FLANGE	FLANGE O/DIA. + THICKNESS	SHAFT DIA.	RECESS DIA.	RECESS DEPTH	HOLE DETAILS (45° OFF CENTRES)	KEY DETAILS	ISO 5211 / MSS SP-101 MOUNTING OPTION	HOLE DETAILS (22.5° OFF CENTRES)	STANDARD	MIN BORE	SQ KEY MAX BORE	SQ KEY SIZE	RECT. KEY MAX BORE	RECT. KEY SIZE	SQ BORE MAX
ISO F16	Ø210 x 20 (Ø8.27" x 0.787")	Ø40.00-0.05 (Ø1.575"-0.002")	Ø130.05+0.15 (Ø5.120"+0.006")	5 (0.20")	4 x Ø20.5 ON Ø165.0 P.C. (4 x Ø0.81" ON Ø6.50" P.C.)	12x8x55 (0.47"x0.31"x2.17")	ISO F35*	8 x M30 x 36 (1.42") DEEP ON Ø356.0 (Ø14.02") P.C.	BS4235	-	-	-	178	45 x 25	□ 132.1 (5.20")
FA16			BS46						-	-	-	6.75"	1.75" x 1.25"		
		Ø126.92+0.18 (Ø4.997"+0.007")				FA35*	8 x 1" UNC x 36 (1.42") DEEP ON Ø355.6 (Ø14.00") P.C.	ANSI B17.1	-	6.50"	1.1/2" SQ.	6.50"	1.5" x 1"		
								DIN 6885	-	-	-	-	178	45 x 25	

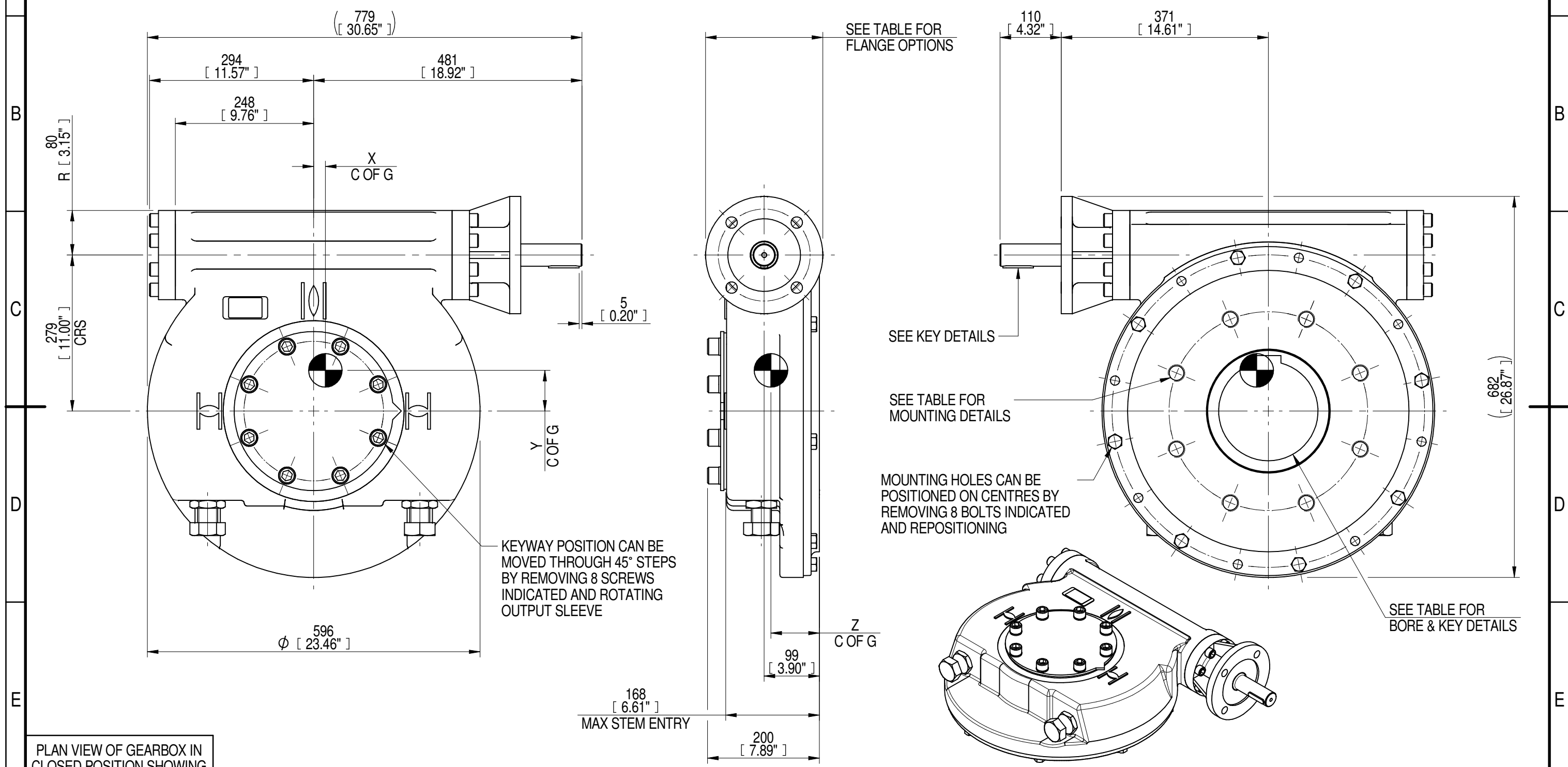

PLAN VIEW OF GEARBOX IN CLOSED POSITION SHOWING STANDARD KEYWAY POSITIONS. ALTERNATIVES AVAILABLE ON REQUEST

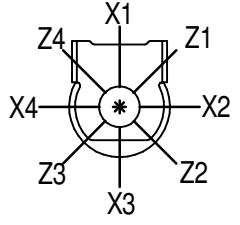

NOTES:
 1. * THREAD DEPTH DOES NOT MATCH ISO STANDARD
 2. CENTRE OF GRAVITY POSITION IS INDICATIVE FOR STANDARD BUILD WHEN IN POSITION SHOWN

60	15	25	230	48809	1952	21	73	87
RATIO	TURNS TO CLOSE	M.A. ± 10%	WEIGHT (Kg)	MAX OUTPUT (Nm)	MAX INPUT (Nm)	X	Y	Z
DESCRIPTION				TORQUE			CENTRE OF GRAVITY	

AS PART OF CONTINUOUS PRODUCT DEVELOPMENT, ALL DETAILS SUBJECT TO CHANGE WITHOUT PRIOR NOTICE. FOR UP TO DATE DETAILS PLEASE VISIT www.rotork.com

rotork Gears
 LEEDS - UK
www.rotork.com

This drawing is confidential and is the property of Rotork Gears and must not be reproduced either wholly or partly. All rights in respect of patents, designs and copyrights are reserved. ©2016

Document Type **PUBLICITY**
 Dimensions in mm

Title
IW/MOW9 QUARTER TURN GEARBOX, 60:1 F16/ FA16 INPUT : F35/ FA35 OUTPUT

Drawing Number
PUB-IW9FB-F16-F35

Sheet 1 of 1 Size A3

Iss. 01