

INPUT FLANGE DETAILS							MOUNTING HOLES - BOLT CIRCLE (OFF CENTRES)								
INPUT FLANGE	FLANGE O/DIA. + THICKNESS	SHAFT DIA.	RECESS DIA.	RECESS DEPTH	HOLE DETAILS (45° OFF CENTRES)	KEY DETAILS	ISO 5211 / MSS SP-101 MOUNTING OPTION	HOLE DETAILS (22.5° OFF CENTRES)	STANDARD	MIN BORE	SQ KEY MAX BORE	SQ KEY SIZE	RECT. KEY MAX BORE	RECT. KEY SIZE	SQ BORE MAX
ISO F10	Ø125 x 15 (Ø4.92" x 0.59")	Ø20.00-0.05 (Ø0.787"-0.002")	Ø70.05+0.15 (Ø2.758"+0.006")	4 (0.16")	4 x Ø10.5 ON Ø102.0 P.C. (4 x Ø0.41" ON Ø4.02" P.C.)	6x6x40 (0.24"x0.24"x1.57")	ISO F30*	8 x M20 x 25 (0.98") DEEP ON Ø298.0 (Ø11.73") P.C.	BS4235	-	-	-	178	45 x 25	□ 132.1 (5.20")
FA10			Ø58.70+0.15 (Ø2.311"+0.006")				FA30*		8 x 3/4" UNC x 25.4 (1.00") DEEP ON Ø298.5 (Ø11.75") P.C.	ANSI B17.1	-	6.50"	1.1/2" SQ.	6.50"	
								DIN 6885	-	-	-	-	178	45 x 25	

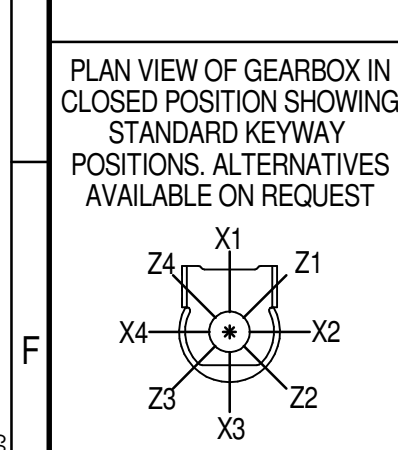
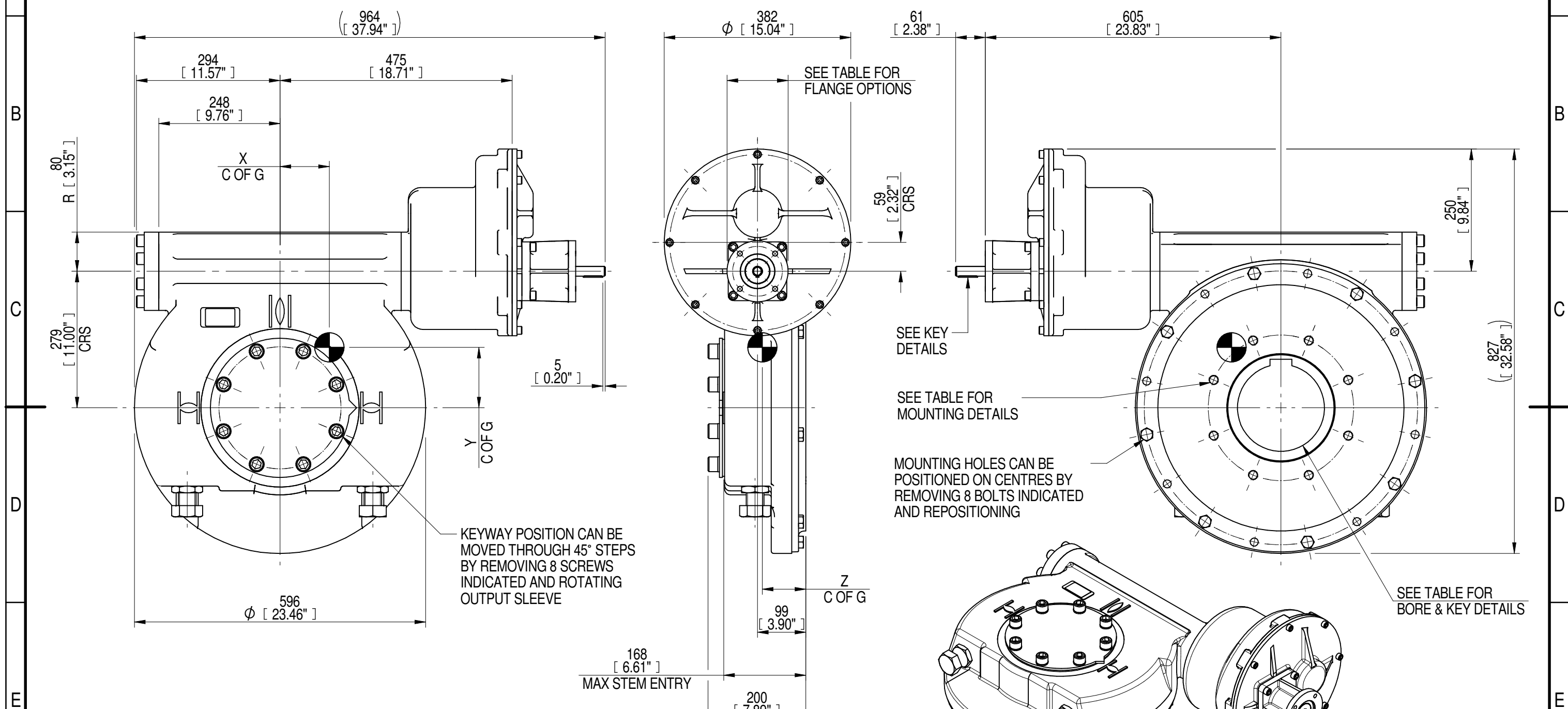

NOTES:
 1. * THREAD DEPTH DOES NOT MATCH ISO STANDARD
 2. CENTRE OF GRAVITY POSITION IS INDICATIVE FOR STANDARD BUILD WHEN IN POSITION SHOWN

RATIO	TURNS TO CLOSE	M.A. ± 10%	WEIGHT (Kg)	MAX OUTPUT (Nm)	MAX INPUT (Nm)	X	Y	Z
3000	750	1188	290	52171	44	101	124	89
2520	630	998	295	52171	52	107	128	89
2160	540	855	289	52171	61	100	123	89
1440	360	570	291	52171	92	101	124	89
1080	270	428	289	52171	122	99	123	89
960	240	380	291	52171	137	101	124	89
DESCRIPTION			TORQUE			CENTRE OF GRAVITY		

AS PART OF CONTINUOUS PRODUCT DEVELOPMENT, ALL DETAILS SUBJECT TO CHANGE WITHOUT PRIOR NOTICE. FOR UP TO DATE DETAILS PLEASE VISIT www.rotork.com

LEEDS - UK
www.rotork.com

This drawing is confidential and is the property of Rotork Gears and must not be reproduced either wholly or partly. All rights in respect of patents, designs and copyrights are reserved. ©2016

Document Type **PUBLICITY**

Dimensions in mm

Title
IW/MOW9 QUARTER TURN GEARBOX, 960/1080/1440/2160/2520/3000 : 1, F10/ FA10 INPUT : F30/ FA30 OUTPUT

Drawing Number
PUB-IW9FBIR3-F10-F30

Iss. 01