

FOR TYPICAL REMOTE CONTROL DETAILS, SEE DOCUMENT **RWS100**

TRANSFORMER TAPPING OPTIONS		
Tap	Nominal 50/60Hz	FUSE FS1
VOLTAGE	50HZ/60HZ	
LOW	115	500mA
HIGH	230	250mA
FUSE FS1 TO BE ANTI SURGE		
CAPACITOR START/RUN (CS/CS2 AND CR/CR2) COMBINATIONS & VALUES		
VARY WITH SUPPLY VOLTAGE & ACTUATOR SIZE.		

REFER TO SHEET 2 FOR NOTES & OPTION PCB'S IF FITTED

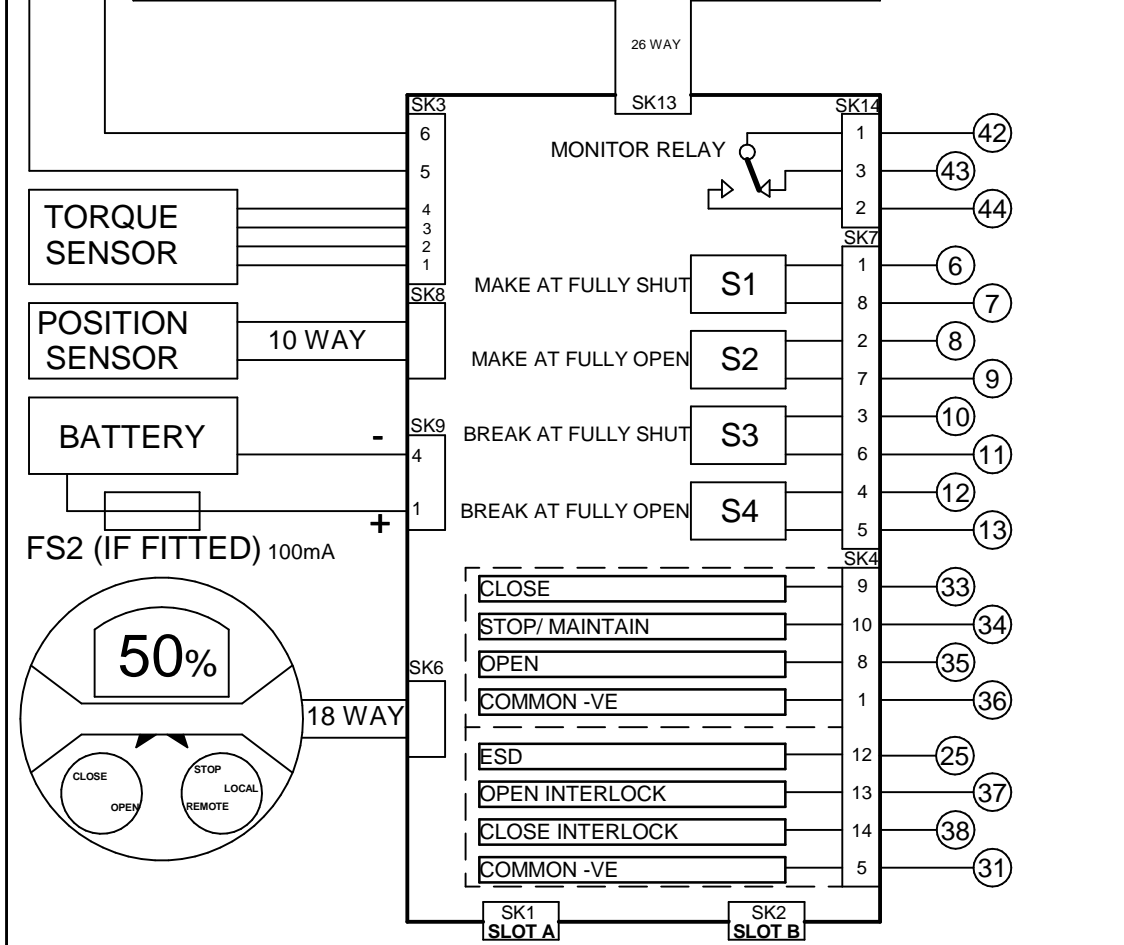

Iss	Date	Chkd	Revision Details
1	210217	JC1	First Issue

www.rotork.com

ROTORK CONTROLS LTD
BATH, BA1 3JQ
ENGLAND
Tel:01225-733200

ROTORK CONTROLS INC
ROCHESTER
NY 14624, USA
Tel:585-247-2304

IQ SINGLE PHASE + SINGLE CHANNEL MODBUS MODULE + ANALOGUE MONITORING		Circuit Diagram Number	Issue No	Sheet
		124M2000	1	1
MI No	Job No	Base WD	Date	Drawn by
---	---	124M2000	210217	PJW

B1	C1	B2	C2						
----	----	----	----	--	--	--	--	--	--

SLOT A

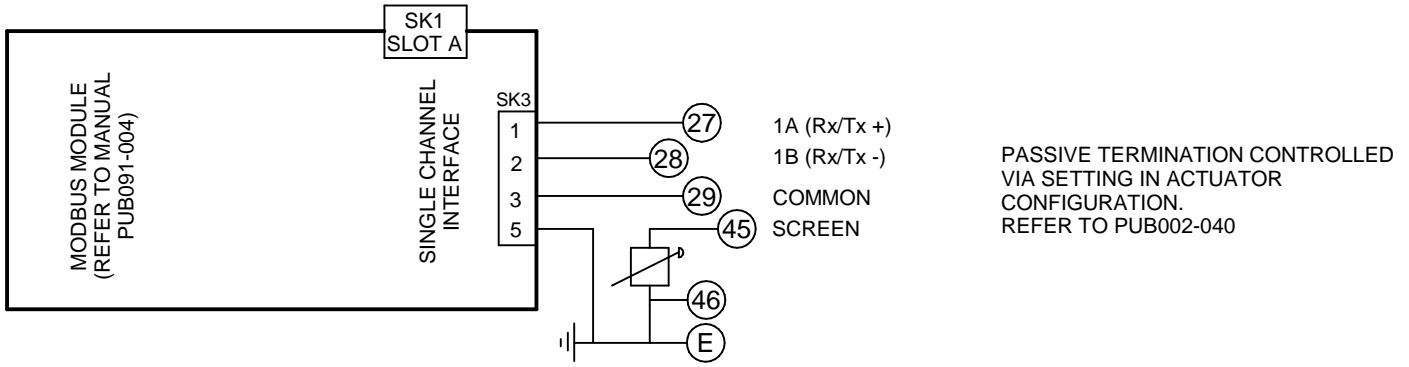

MODBUS RS485 SIGNAL LINES REQUIRE EXTERNAL ACTIVE BIASING TO BE PROVIDED AT ONE LOCATION FOR THE WHOLE BUS SEGMENT. REFER TO PUB091-004.

SLOT B

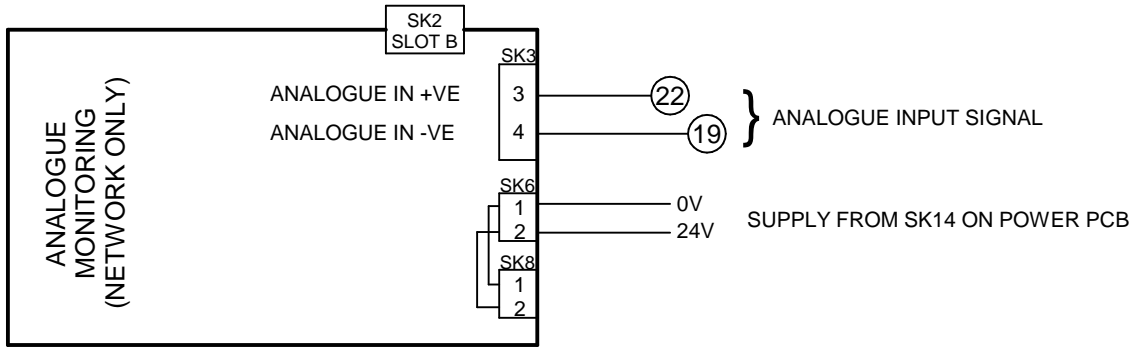

NOTES

1.FUSES:

- PS1 is a self-resetting fuse.
- Refer to publication PUB002-039 for approved fuses FS1 and FS2.
- Actuator rated voltage specified on nameplate. Voltage tolerance +/-10%, applies for rated torque performance; duty cycle is not guaranteed.

2.REMOTE CONTROL:

- For typical remote control circuits refer to:
 - RWS indicated or PUB002-041.
- For DC and AC control, connect -ve/0V to terminal 36.
- (For negative switch / positive common, refer to RWS indicated).
- Control signal threshold voltages:
 - DC: "on" $\geq 16Vdc$ / "off" $\leq 8Vdc$, max 60Vdc.
 - AC: "on" $\geq 60Vac$ / "off" $\leq 40Vac$, max 120Vac.
- Control signal duration to be 300ms minimum.
- Maximum current drawn from remote control signals is:
 - 8mA at 24Vdc or 12mA at 120Vac.
- Supply provided on terminals 4 & 5:
 - Intended for remote control.
 - Max external load 5W at 24Vdc / 5VA at 120Vac

3.INDICATION:

- For typical position, status and alarm indication see PUB002-041.
- “S” contacts are user configurable and are shown in their default setting.
- Refer to PUB002-040 for functions and configuration instructions.
- Monitor Relay indicates actuator availability for remote control (shown “unavailable”). It can be configured to exclude local/remote selection.
- Refer to PUB002-040 for monitored functions and configuration instructions.
- Voltage applied to indication contacts must not exceed 150Vac
- Individual Switch current must not exceed 3.5A inductive, 5A resistive and no more than 8A in total for all 4 contacts.

4.BATTERY:

- Battery maintains local and remote “S” contact indication only.
- Refer to installation manual for approved replacement battery types.