

CIRCUIT DRAWN WITH POWER SUPPLY OFF
 PLUG SELECTED VOLTAGE WIRE INTO TERMINAL "T"
 PLACE TWO REMAINING WIRES INTO POSITIONS "P"
 (ORDER NOT IMPORTANT)

FOR TYPICAL REMOTE CONTROL
 DETAILS, SEE DOCUMENT
RWS100

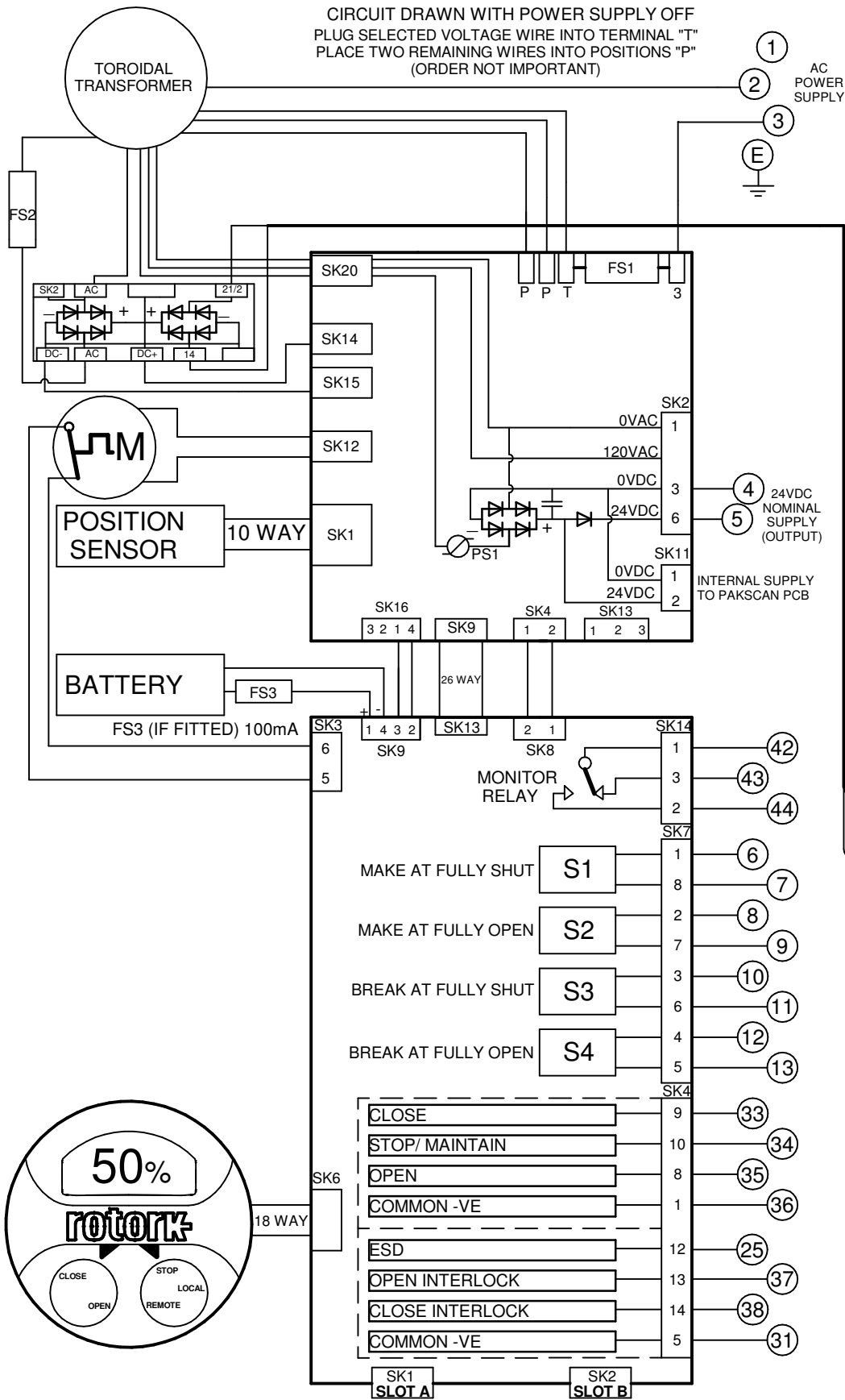

TRANSFORMER VOLTAGE OPTIONS:
 CONNECT CORRESPONDING
 COLOUR TO "T"

TYPE 1		
GREY	100V	FS1 - 5A ANTISURGE
PURPLE	110V	
BROWN	120V	
TYPE 2		
GREY	200V	FS1 - 2.5A ANTISURGE
PURPLE	230V	
BROWN	270V	
TYPE 3		
GREY	380V	FS1 - 2.0A ANTISURGE
PURPLE	400V	
BROWN	415V	
TYPE 4		
GREY	480V	FS1 - 2.0A ANTISURGE
PURPLE	575V	
BROWN	690V	

FS2 - 20A ATO FAST ACTING ALL TYPES

REFER TO SHEET 2 FOR NOTES
 & OPTION PCB'S IF FITTED

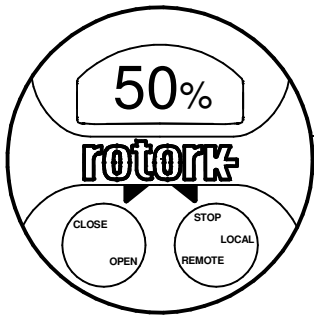
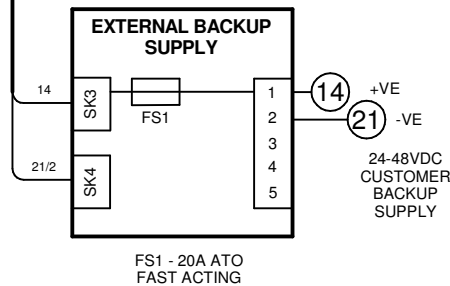

Iss	Date	Chkd	Revision Details
1	070617	JC1	First Issue.
2	270619	PMJ	PUB002-065 WAS -039

www.rotork.com

ROTORK CONTROLS LTD
 BATH, BA1 3JQ
 ENGLAND
 Tel:01225-733200

ROTORK CONTROLS INC
 ROCHESTER
 NY 14624, USA
 Tel:585-247-2304

IQT + PAKSCAN + EXTERNAL BATTERY BACKUP

Drawn by: PJW
 Date : 070617
 Base WD: 380K2000
 Job No : --
 MI No : --

Circuit Diagram Number		Issue No	Sheet
380K2000		2	1 of 2
B1	C1	B2	C2

SLOT A

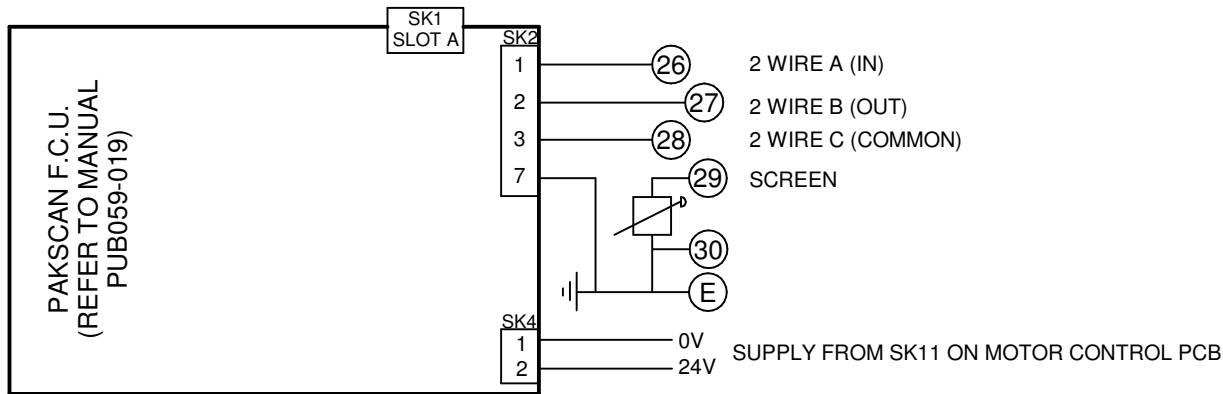

CARE SHOULD BE TAKEN TO ENSURE THAT CIRCUITS CONNECTED TO TERMINALS 4 OR 5 ARE NOT DIRECTLY OR INDIRECTLY CONNECTED TO GROUND.

THE SETTING TOOL ENABLES THE PAKSCAN F.C.U BAUD RATE AND ADDRESS TO BE CONFIGURED

NOTES

1.FUSES:

- PS1 is a self-resetting fuse.
- Refer to publication PUB002-065 for approved fuses FS1 and FS2.
- Actuator rated voltage specified on nameplate. Voltage tolerance +/-10% applies for rated torque performance; duty cycle is not guaranteed.

2.REMOTE CONTROL:

- For typical remote control circuits refer to:
 - RWS indicated or PUB002-041.
- For DC and AC control, connect -ve/0V to terminal 36.
- (For negative switch / positive common, refer to RWS indicated).
- Control signal threshold voltages:
 - DC: "on" $\geq 16\text{Vdc}$ / "off" $\leq 8\text{Vdc}$, max 60Vdc.
 - AC: "on" $\geq 60\text{Vac}$ / "off" $\leq 40\text{Vac}$, max 120Vac.
- Control signal duration to be 300ms minimum.
- Maximum current drawn from remote control signals is:
 - 8mA at 24Vdc or 12mA at 120Vac.
- Supply provided on terminals 4 & 5:
 - Intended for remote control.
 - Max external load 5W at 24Vdc / 5VA at 120Vac

3.INDICATION:

- For typical position, status and alarm indication see PUB002-041.
- "S" contacts are user configurable and are shown in their default setting.
- Refer to PUB002-040 for functions and configuration instructions.
- Monitor Relay indicates actuator availability for remote control (shown "unavailable"). It can be configured to exclude local/remote selection.
- Refer to PUB002-040 for monitored functions and configuration instructions.
- Voltage applied to indication contacts must not exceed 150Vac
- Individual Switch current must not exceed 3.5A inductive, 5A resistive and no more than 8A in total for all 4 contacts.

4.BATTERY:

- Battery maintains local and remote "S" contact indication only.
- Refer to installation manual for approved replacement battery types.