

CIRCUIT DRAWN WITH POWER SUPPLY OFF

FOR TYPICAL REMOTE CONTROL  
DETAILS, SEE DOCUMENT  
**RWS100**

TRANSFORMER TAPPING OPTIONS	
Tap	Nominal 50/60Hz
TYPE 1	
W	220/230
X	380/400
Y	400,415/420
Z	440/460
FUSE FS 1=250mA ANTI-SURGE	
TYPE 2	
W	346/380
X	480/500
Y	240/240
Z	550/575
FUSE FS 1=250mA ANTI-SURGE	

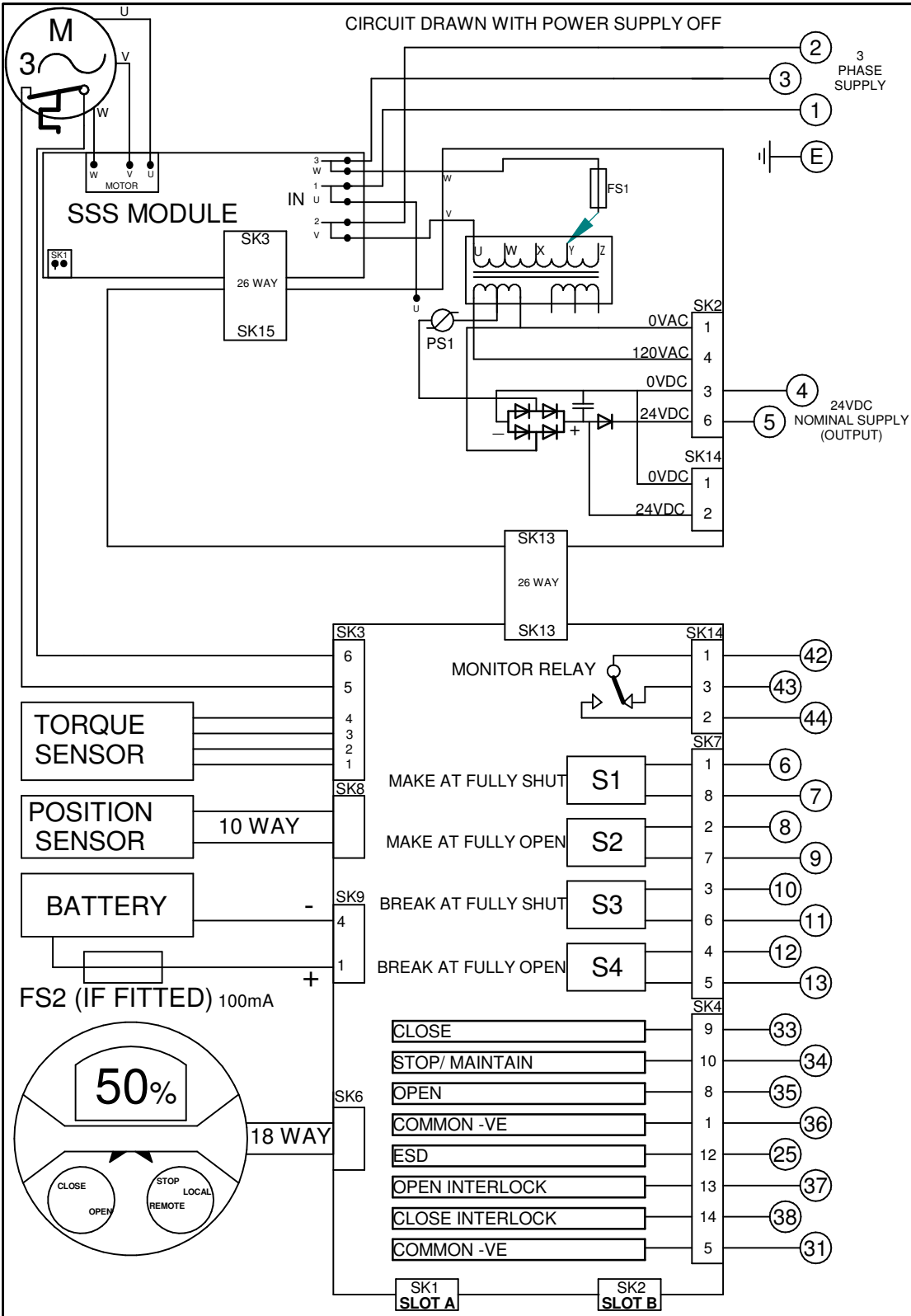

REFER TO SHEET 2 FOR NOTES  
& OPTION PCB'S IF FITTED

THE ACTUATOR MUST BE  
PROTECTED USING SUITABLY  
RATED HIGH SPEED  
SEMI-CONDUCTOR FUSES ON THE  
INCOMING SUPPLY.  
SUGGESTED FUSES :-  
IQ10-20:10 Amp FERRAZ G330010  
IQ25-35:20 Amp FERRAZ K330013  
ALTERNATIVES =  
IQ10-20:10 Amp SIBA 50-179-06/10A  
IQ25-35:20 Amp SIBA 50-179-06/20A  
OR EQUIVALENT PROTECTIVE  
DEVICE.

Iss	Date	Chkd	Revision Details	<b>www.rotork.com</b>	IQM + SINGLE CHANNEL PROFIBUS MODULE + RHS	Circuit Diagram Number <b>200P2006</b>	Issue No <b>2</b>	Sheet <b>1</b> of 2
1	210717	JC1	First Issue.					
2	250718	PJW	PROFIBUS PUB SHT2 UPDATED WAS PUB008-005	ROTORK CONTROLS LTD BATH, BA1 3JQ ENGLAND Tel:01225-733200	ROTORK CONTROLS INC ROCHESTER NY 14624, USA Tel:585-247-2304	Drawn by: PJW Date : 210717 Base WD: 200P2006 Job No : -- MI No : --		

# SLOT A

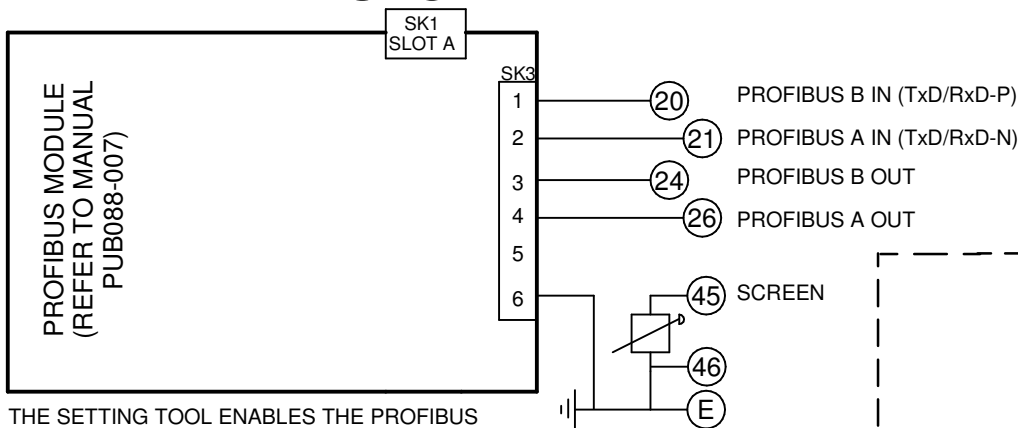

THE SETTING TOOL ENABLES THE PROFIBUS ADDRESS TO BE CONFIGURED.

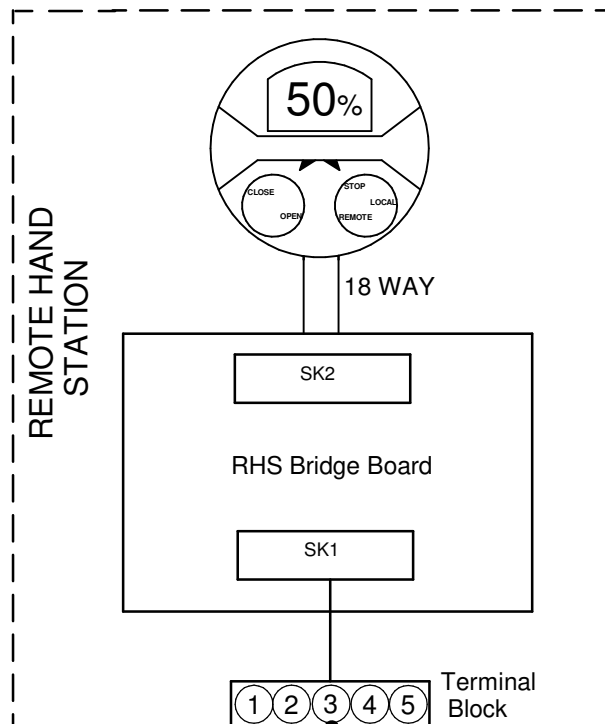

# SLOT B

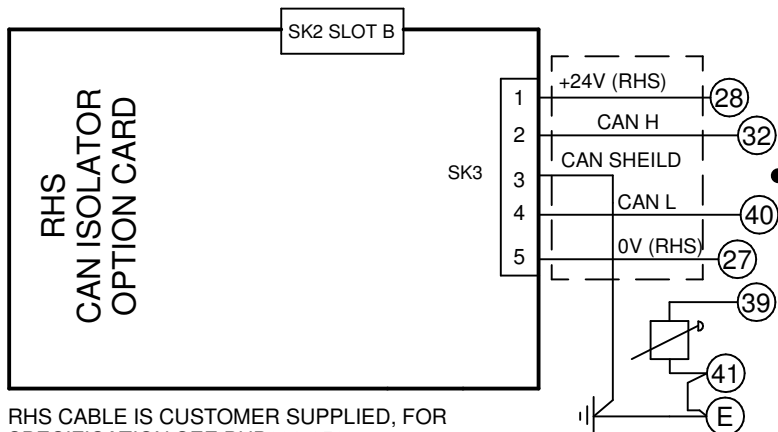

RHS CABLE IS CUSTOMER SUPPLIED, FOR SPECIFICATION SEE PUB002-059, MAXIMUM LENGTH OF CABLE TO BE 100M.

Actuator Terminal Bung No.	RHS Terminal Block No.	Function
28	1	+24V (RHS)
27	2	0V (RHS)
32	3	CAN H
40	4	CAN L
39	5	SHEILD

## NOTES

### 1.FUSES:

- PS1 is a self-resetting fuse.
- Refer to publication PUB002-039 for approved fuses FS1 and FS2.
- Actuator rated voltage specified on nameplate. Voltage tolerance +/-10%, applies for rated torque performance; duty cycle is not guaranteed.

### 2.REMOTE CONTROL:

- For typical remote control circuits refer to:
  - RWS indicated or PUB002-041.
  - For DC control connect -ve to terminal 36.
  - (For negative switch / positive common, refer to RWS indicated).
- Control signal threshold voltages:
  - DC: "on" ≥16Vdc / "off" ≤8Vdc, max 60Vdc.
  - Control signal duration to be 100ms minimum.
- Maximum current drawn from remote control signals is:
  - 8mA at 24Vdc.
- Supply provided on terminals 4 & 5:
  - Intended for remote control.
  - Max external load 5W at 24Vdc

### 3.INDICATION:

- For typical position, status and alarm indication see PUB002-041.
- “S” contacts are user configurable and are shown in their default setting.
- Refer to PUB002-040 for functions and configuration instructions.
- Monitor Relay indicates actuator availability for remote control (shown “unavailable”). It can be configured to exclude local/remote selection.
- Refer to PUB002-040 for monitored functions and configuration instructions.
- Voltage applied to indication contacts must not exceed 150Vac
- Individual Switch current must not exceed 3.5A inductive, 5A resistive and no more than 8A in total for all 4 contacts.

### 4.BATTERY:

- Battery maintains local and remote “S” contact indication only.
- Refer to installation manual for approved replacement battery types.