

NOTES:

1. 4-20 mA OUTPUT, 24VDC NOMINAL, (18-30 VDC MAX)
2. SEE ADDITIONAL PAGES FOR COMMUNICATIONS W/D IF ATTACHED

SHT
1 OF 3

A

M12-D0

REV
A

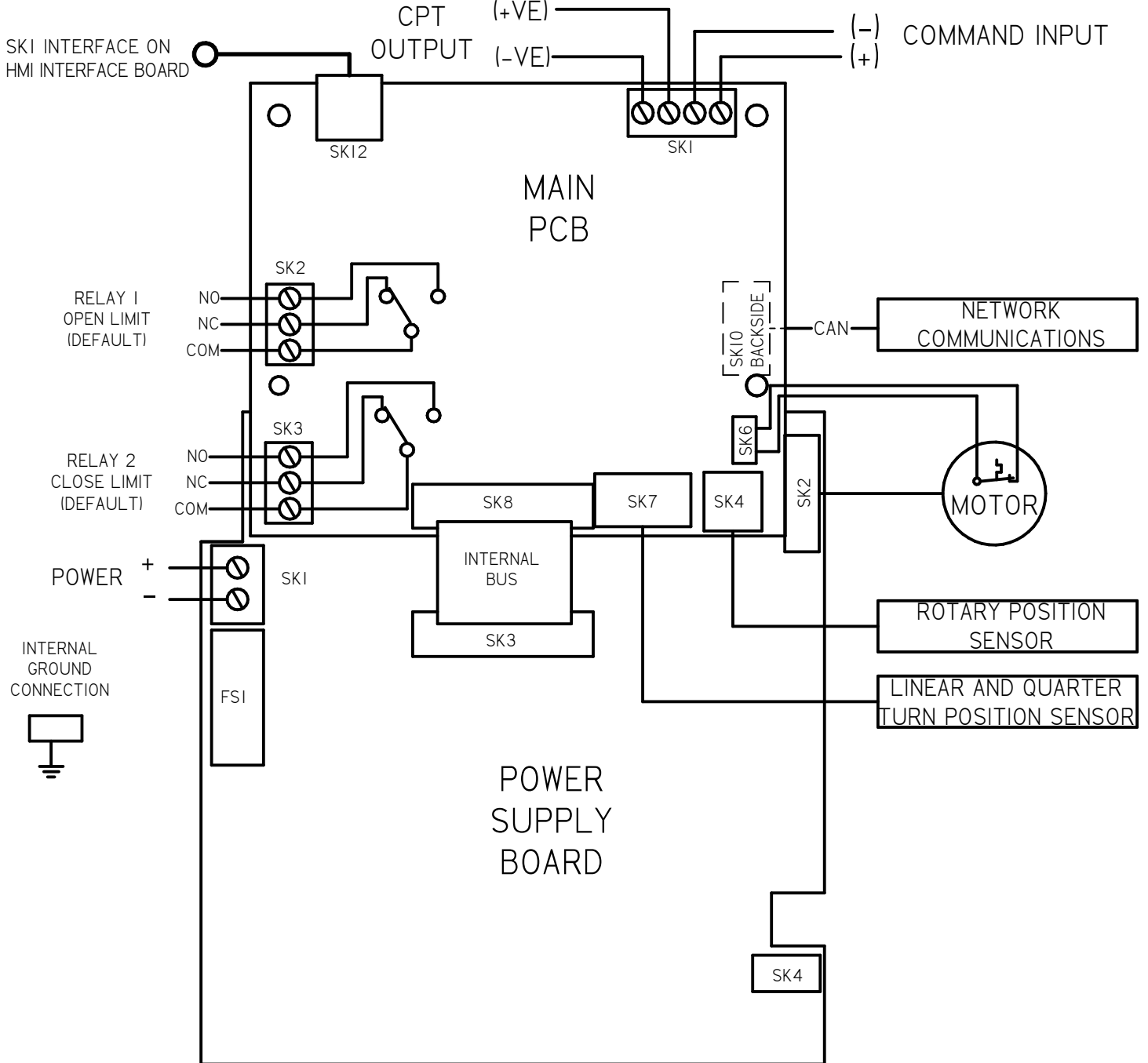

A	INITIAL RELEASE	GVM 12-29-17
REV	DESCRIPTION	DATE

<p>TOLERANCES UNLESS OTHERWISE SPECIFIED .XX = ±.02 XXX = ±.005 ANGULAR ±1°</p>		
<p>SCALE: NTS</p>		
DRAWN: GVM	PROD. DV.	PROD. ENG.
DATE: 1-12-15	DATE:	DATE:

rotork[®]
Process Controls
MILWAUKEE, WISCONSIN, USA

This print is the property of Rotork Process Controls and is loaned in confidence subject to return. All rights to design or invention are reserved.

TITLE :
CMA WIRING DIAGRAM

FOR :
DC POWER OPERATION
LOCAL CONTROLS, RIRO TERMINAL
CONNECTIONS

SHT
1 OF 3

A

M12-D0

HMI INTERFACE BOARD



SK12 INTERFACE ON
MAIN PCB BOARD

A	INITIAL RELEASE	GVM	12-29-17		
REV	DESCRIPTION	DATE			
<p>TOLERANCES UNLESS OTHERWISE SPECIFIED .XX = ±.02 XXX = ±.005 ANGULAR ±1°</p>			 MILWAUKEE, WISCONSIN, USA		TITLE : CMA WIRING DIAGRAM
SCALE: NTS					FOR : DC POWER OPERATION LOCAL CONTROLS, RIRO TERMINAL CONNECTIONS
DRAWN:	PROD. DV.	PROD. ENG.	This print is the property of Rotork Process Controls and is loaned in confidence subject to return. All rights to design or invention are reserved.		SHT 2 OF 3 A M12-D0
DRAWN: GVM					
DATE:	DATE:	DATE:			
DATE: 1-12-15					

RIRO REMOTE INPUTS - DEFAULT SETTINGS

INPUT	FUNCTION	CONTACT FORM
I/P1	CLOSE COMMAND	NORMALLY OPEN
I/P2	STOP/MAINTAIN	NORMALLY OPEN
I/P3	OPEN COMMAND	NORMALLY OPEN
I/P4	ESD	NORMALLY OPEN

REFER TO PUB094-004 FOR FULL DETAILS

RIRO RELAY OUTPUTS- DEFAULT SETTINGS

INPUT	FUNCTION	CONTACT FORM
RELAY 5	NONE	ENERGIZE ON CONDITION
RELAY 6	NONE	ENERGIZE ON CONDITION
RELAY 7	NONE	ENERGIZE ON CONDITION
RELAY 8	NONE	ENERGIZE ON CONDITION

REFER TO PUB094-004 FOR FULL DETAILS

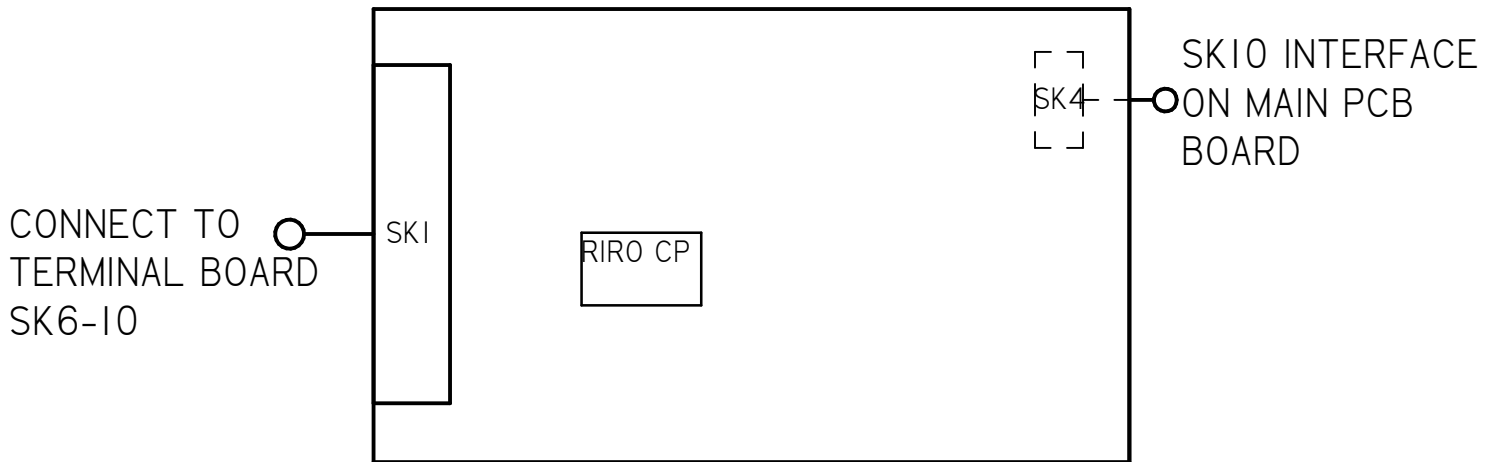
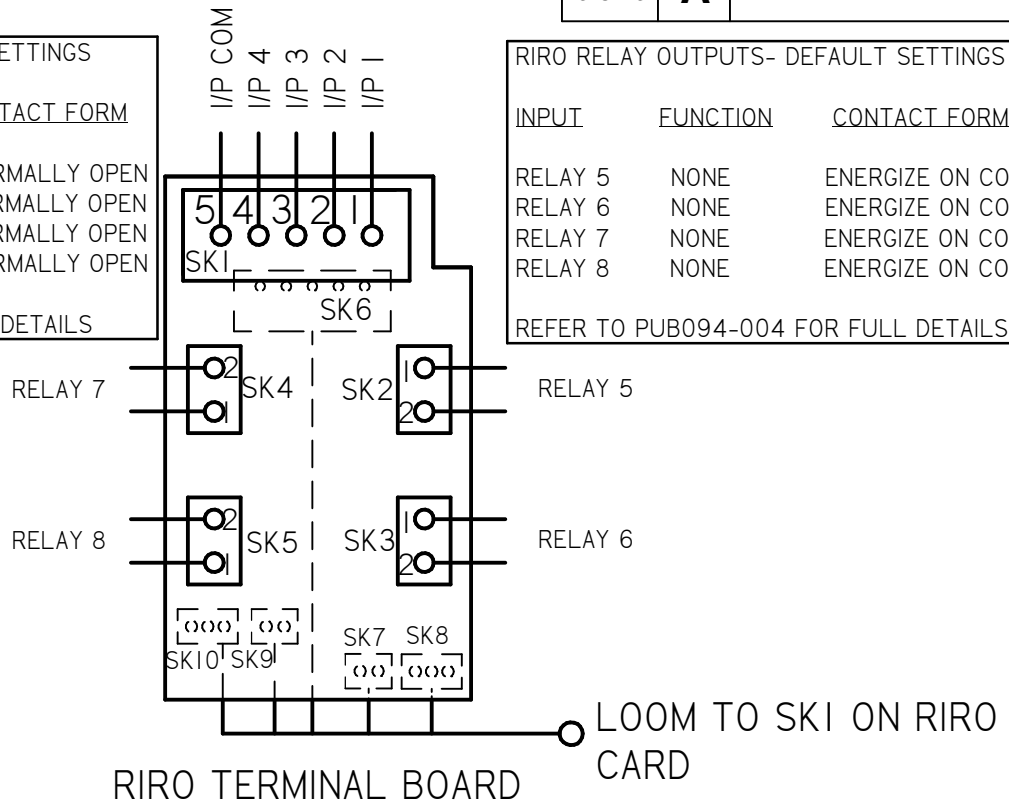

A	INITIAL RELEASE	GVM 12-29-17
REV	DESCRIPTION	DATE

TOLERANCES
UNLESS OTHERWISE SPECIFIED
.XX = ±.02 XXX = ±.005 ANGULAR ±1°

SCALE: **NTS**

DRAWN: GVM	PROD. DV.	PROD. ENG.
DATE: 1-12-15	DATE:	DATE:

rotork
Process Controls
MILWAUKEE, WISCONSIN, USA

This print is the property of Rotork Process Controls and is loaned in confidence subject to return. All rights to design or invention are reserved.

TITLE :
CMA WIRING DIAGRAM

FOR :
DC POWER OPERATION
LOCAL CONTROLS, RIRO TERMINAL
CONNECTIONS