

A	INITIAL RELEASE	ECE
REV	DESCRIPTION	DATE

NOTES:
 1. 4-20 mA OUTPUT, 24VDC NOMINAL, (18-30 VDC MAX)
 2. SEE ADDITIONAL PAGES FOR COMMUNICATIONS WD IF ATTACHED

TOLERANCES UNLESS OTHERWISE SPECIFIED .XX = ±.02 XXX = ±.005 ANGULAR ±1°		
SCALE: NTS		
DRAWN: ECE	PROD. DV.	PROD. ENG.
DATE: 12APR18	DATE:	DATE:

rotork[®]
Controls

MILWAUKEE, WISCONSIN, USA

This print is the property of Rotork Process Controls and is loaned in confidence subject to return. All rights to design or invention are reserved.

TITLE : CMA 1500 & 3000 WIRING DIAGRAM	
FOR : 24V DC POWER OPERATION LOCAL CONTROLS, RIRO, MODBUS SINGLE CHANNEL	
SHT 1 OF 3	M42-MD

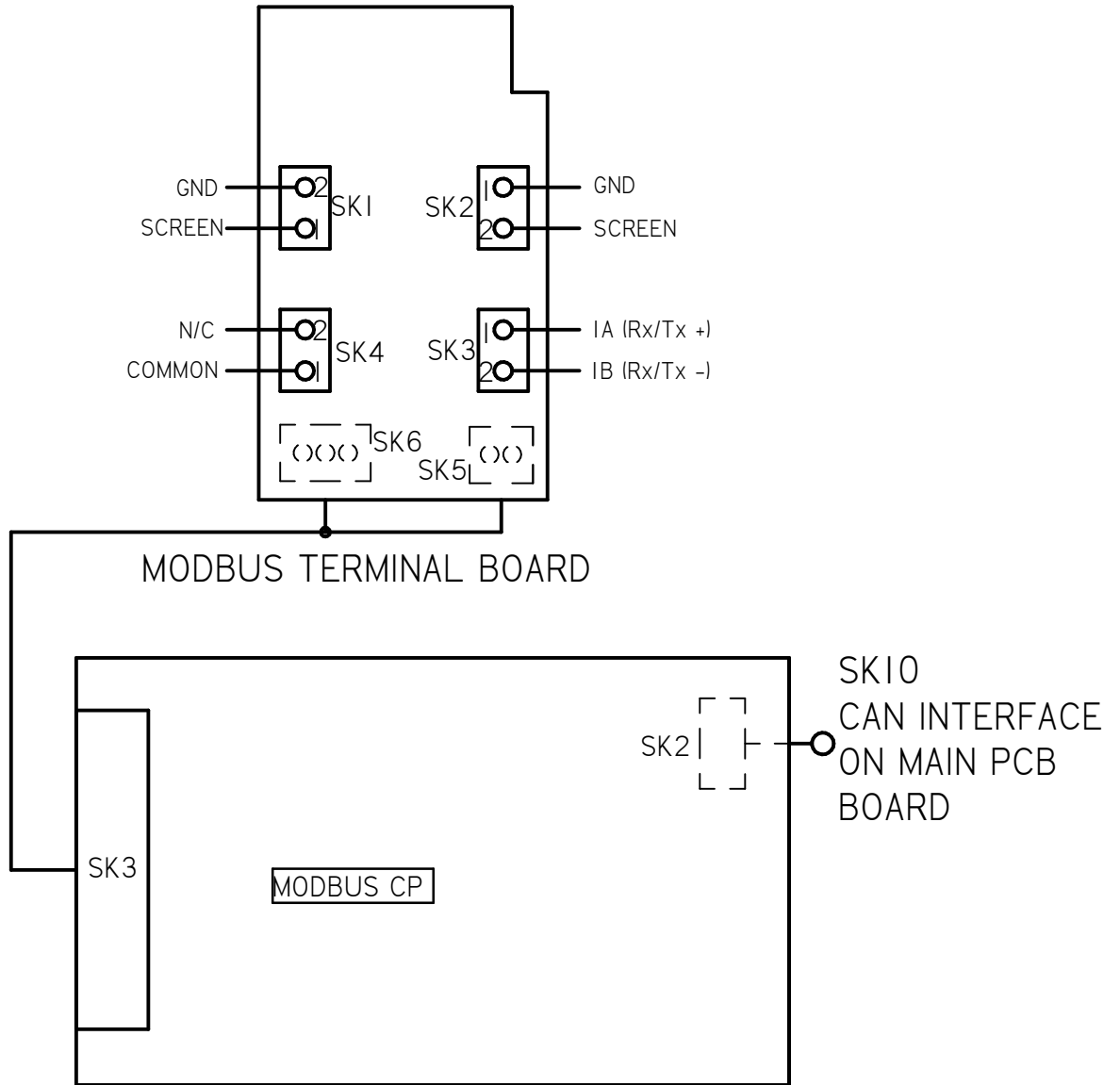

A	INITIAL RELEASE	ECE		12APR18	
REV	DESCRIPTION	DATE			
TOLERANCES UNLESS OTHERWISE SPECIFIED .XX = ±.02 XXX = ±.005 ANGULAR ±1°			 MILWAUKEE, WISCONSIN, USA		TITLE : CMA 1500 & 3000 WIRING DIAGRAM
SCALE: NTS					FOR : 24V DC POWER OPERATION LOCAL CONTROLS, RIRO, MODBUS SINGLE CHANNEL
DRAWN:	PROD. DV.	PROD. ENG.		This print is the property of Rotork Process Controls and is loaned in confidence subject to return. All rights to design or invention are reserved.	SHT 2 OF 3
ECE					
DATE:	DATE:	DATE:			M42-MD
12APR18					

RIRO REMOTE INPUTS - DEFAULT SETTINGS		
INPUT	FUNCTION	CONTACT FORM
I/P1	CLOSE COMMAND	NORMALLY OPEN
I/P2	STOP/MAINTAIN	NORMALLY OPEN
I/P3	OPEN COMMAND	NORMALLY OPEN
I/P4	ESD	NORMALLY OPEN

REFER TO PUB094-004 FOR FULL DETAILS

RIRO RELAY OUTPUTS- DEFAULT SETTINGS		
INPUT	FUNCTION	CONTACT FORM
RELAY 5	NONE	ENERGIZE ON CONDITION
RELAY 6	NONE	ENERGIZE ON CONDITION
RELAY 7	NONE	ENERGIZE ON CONDITION
RELAY 8	NONE	ENERGIZE ON CONDITION

REFER TO PUB094-004 FOR FULL DETAILS

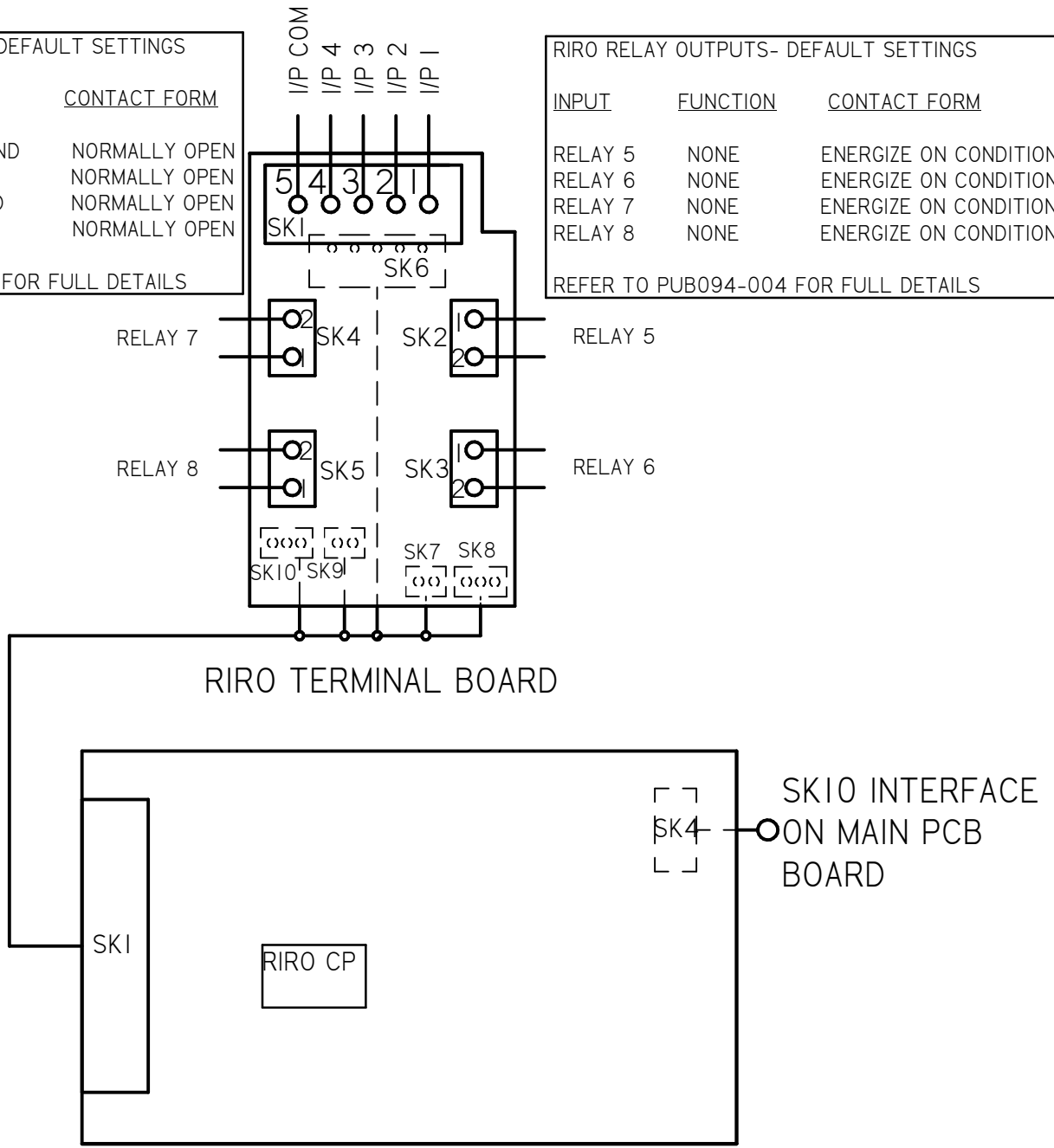

A	INITIAL RELEASE	ECE 12APR18
REV	DESCRIPTION	DATE

TOLERANCES UNLESS OTHERWISE SPECIFIED .XX = ±.02 XXX = ±.005 ANGULAR ±1°		
SCALE: NTS		
DRAWN: ECE	PROD. DV.	PROD. ENG.
DATE: 12APR18	DATE:	DATE:

rotork
Controls
 MILWAUKEE, WISCONSIN, USA

This print is the property of Rotork Process Controls and is loaned in confidence subject to return. All rights to design or invention are reserved.

TITLE : CMA 1500 & 3000 WIRING DIAGRAM	
FOR : 24V DC POWER OPERATION LOCAL CONTROLS, RIRO, MODBUS SINGLE CHANNEL	
SHT 3 OF 3	M42-MD