

A	INITIAL RELEASE	ECE 12APR18
REV	DESCRIPTION	DATE

NOTES:
 1. 4-20 mA OUTPUT, 24VDC NOMINAL, (18-30 VDC MAXI)
 2. SEE ADDITIONAL PAGES FOR COMMUNICATIONS WD IF ATTACHED

TOLERANCES UNLESS OTHERWISE SPECIFIED .XX = ±.02 XXX = ±.005 ANGULAR ±1°		
SCALE: NTS		
DRAWN: ECE	PROD. DV.	PROD. ENG.
DATE: 12APR18	DATE:	DATE:

rotork[®]
Controls

MILWAUKEE, WISCONSIN, USA

This print is the property of Rotork Process Controls and is loaned in confidence subject to return. All rights to design or invention are reserved.

TITLE : CMA 1500 & 3000 WIRING DIAGRAM	
FOR : 12V DC POWER OPERATION LOCAL CONTROLS, RIRO, PROFIBUS	
SHT 1 OF 3	M52-PD

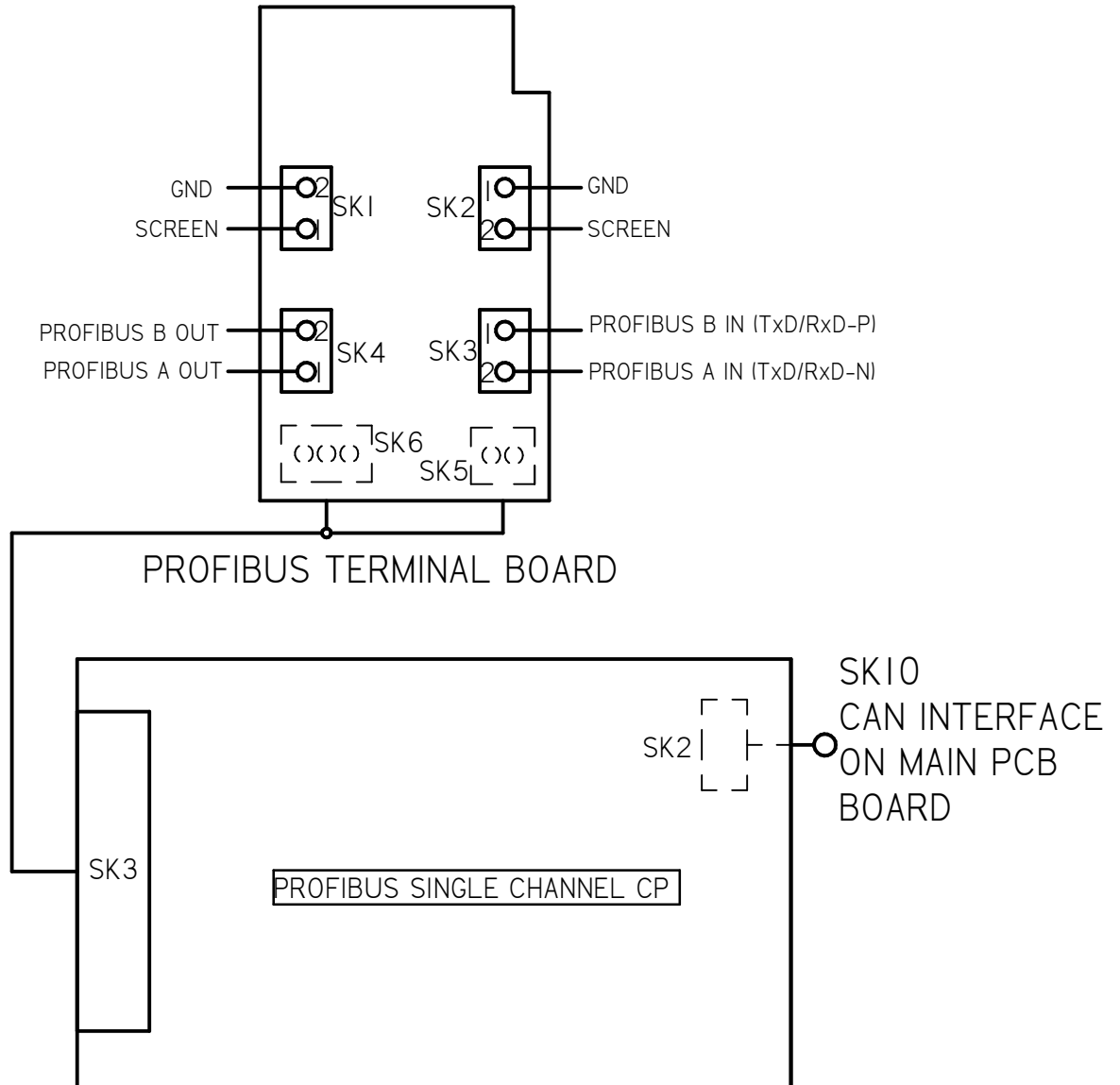

A	INITIAL RELEASE	ECE		12APR18	
REV	DESCRIPTION	DATE			
TOLERANCES UNLESS OTHERWISE SPECIFIED .XX = ±.02 XXX = ±.005 ANGULAR ±1°			 MILWAUKEE, WISCONSIN, USA		TITLE : CMA 1500 & 3000 WIRING DIAGRAM
SCALE: NTS					FOR : 12V DC POWER OPERATION LOCAL CONTROLS, RIRO, PROFIBUS
DRAWN:	PROD. DV.	PROD. ENG.			
ECE					
DATE:	DATE:	DATE:			
12APR18				SHT 2 OF 3	M52-PD
			This print is the property of Rotork Process Controls and is loaned in confidence subject to return. All rights to design or invention are reserved.		

RIRO REMOTE INPUTS - DEFAULT SETTINGS		
INPUT	FUNCTION	CONTACT FORM
I/P1	CLOSE COMMAND	NORMALLY OPEN
I/P2	STOP/MAINTAIN	NORMALLY OPEN
I/P3	OPEN COMMAND	NORMALLY OPEN
I/P4	ESD	NORMALLY OPEN

REFER TO PUB094-004 FOR FULL DETAILS

RIRO RELAY OUTPUTS- DEFAULT SETTINGS		
INPUT	FUNCTION	CONTACT FORM
RELAY 5	NONE	ENERGIZE ON CONDITION
RELAY 6	NONE	ENERGIZE ON CONDITION
RELAY 7	NONE	ENERGIZE ON CONDITION
RELAY 8	NONE	ENERGIZE ON CONDITION

REFER TO PUB094-004 FOR FULL DETAILS

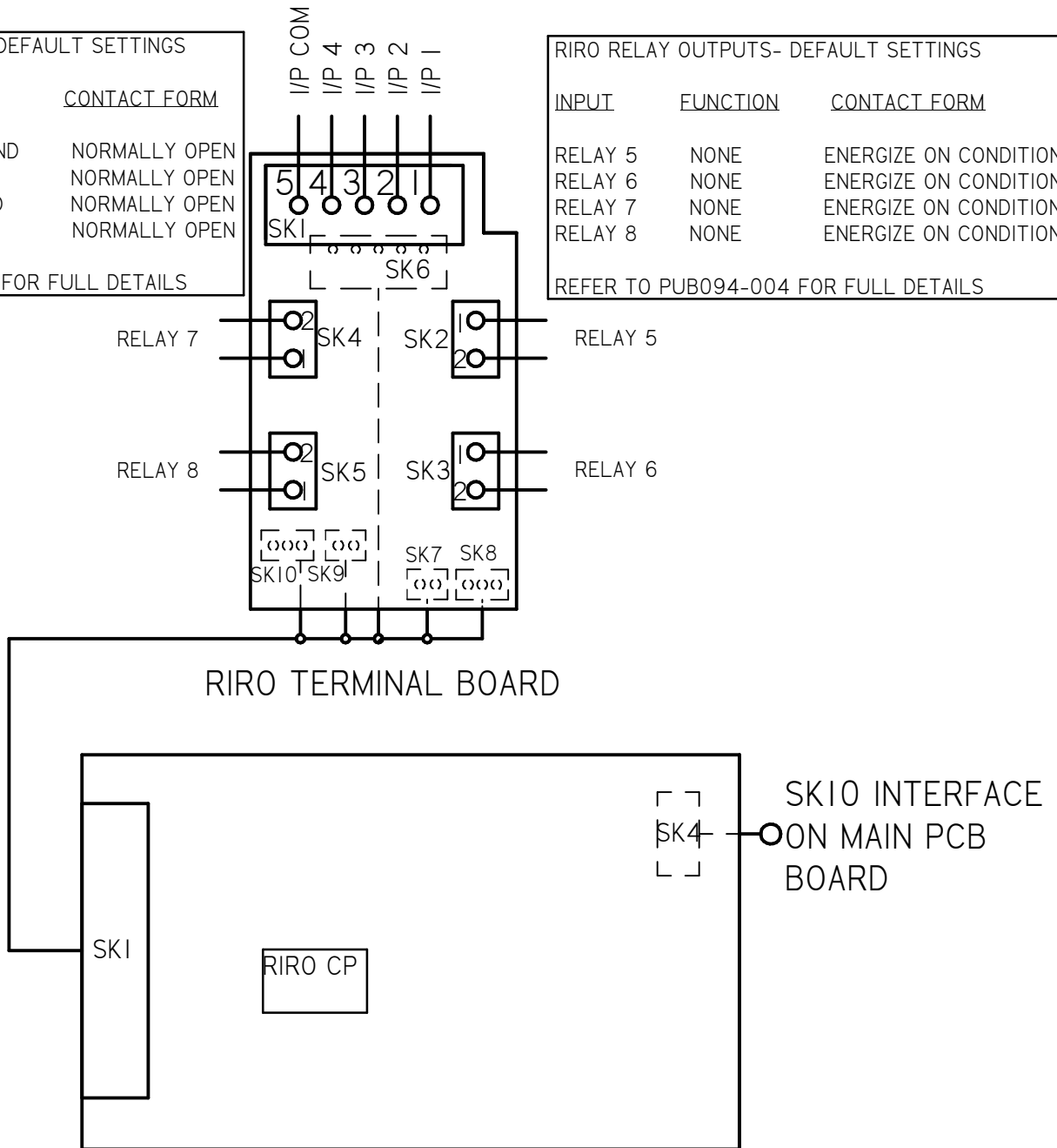

A	INITIAL RELEASE	ECE 12APR18
REV	DESCRIPTION	DATE

TOLERANCES UNLESS OTHERWISE SPECIFIED .XX = ±.02 XXX = ±.005 ANGULAR ±1°		
SCALE: NTS		
DRAWN: ECE	PROD. DV.	PROD. ENG.
DATE: 12APR18	DATE:	DATE:

 MILWAUKEE, WISCONSIN, USA

This print is the property of Rotork Process Controls and is loaned in confidence subject to return. All rights to design or invention are reserved.

TITLE : CMA 1500 & 3000 WIRING DIAGRAM	
FOR : 12V DC POWER OPERATION LOCAL CONTROLS, RIRO, PROFIBUS	
SHT 3 OF 3	M52-PD