

- NOTE:**
1. GEARBOX RATIOS : 350, 420:1
  2. GEARBOX BASEPLATE: F16/FA16, F25/FA25 & F30/FA30
  3. DIMENSIONS WITH "\*" INDICATE COVER REMOVAL ALLOWANCE
  4. THE INTERFACE PROVIDED FOR MOUNTING THE ACTUATOR OR SECOND STAGE GEARBOX ONTO THE VALVE SHOULD CONFORM TO GOOD ENGINEERING PRACTICES, ENSURING ADEQUATELY TOLERANCED LIMITS FOR PARALLELISM, PERPENDICULARITY AND CONCENTRICITY.
  5. ROTORK CANNOT BE HELD LIABLE FOR DAMAGE TO OUR EQUIPMENT CAUSED BY EXCESSIVE LOADING FROM COVER TUBES, HANDWHEEL AND HAND LEVER.

PARAMETER	VALUE	DESCRIPTION
DRAWING TYPE	A	INSTALLATION DRAWING
ACTUATOR	4	CK(R)C30/60
GEARBOX1	W6	IW6
GEARBOX2	RH	HIGH RATIO
CENTRONIK / TERMINAL	B	CTK/3 COND
MECHANISM / MOTOR	S	STD.MECH./SMALL MOT.
HANDWHEEL / REAR / FRONT	0	STD.H.W./STD.REAR/STD.FRNT.
ORIENTATION	0	STD.ORIENT.

<b>CK range</b>	Drawn	BHARAT	27-07-18
	Checked	BHARAT	27-07-18
	Approved	JOSE	27-07-18

<b>Title</b>	DIMENSIONAL DRAWING, CKC30/60 & CKRC30/60, IW6, HIGH RATIO, CENTRONIK / 3 CONDUIT ENTRIES, SMALL MOTOR, STANDARD ORIENTATION.
--------------	---

<b>A4</b>	<b>Doc Number</b>	<b>Ver No</b>	<b>Scale</b>	<b>Sheet No</b>
	<b>A4W6RHBS00X</b>	<b>1</b>	<b>NTS</b>	<b>1 of 2</b>

CONDUIT ENTRY HOLE		
Hole	Metric	NPT
A	M32	1 1/4"
B	M25	3/4"
C	M20	3/4"

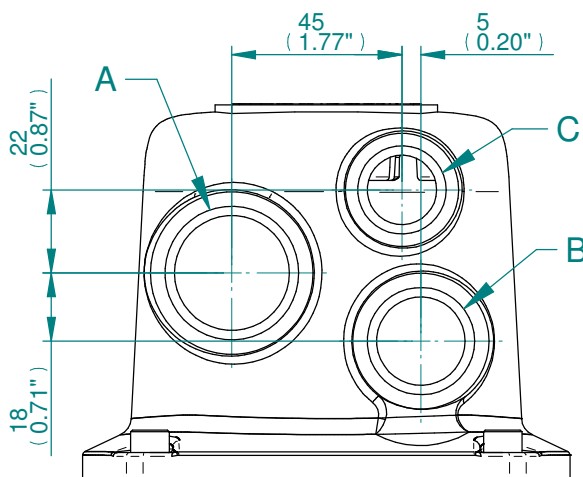

CONDUIT ENTRIES

MOUNTING HOLES CAN BE POSITIONED ON/OFF CENTRES BY REMOVING 8 BOLTS INDICATED AND REPOSITIONING

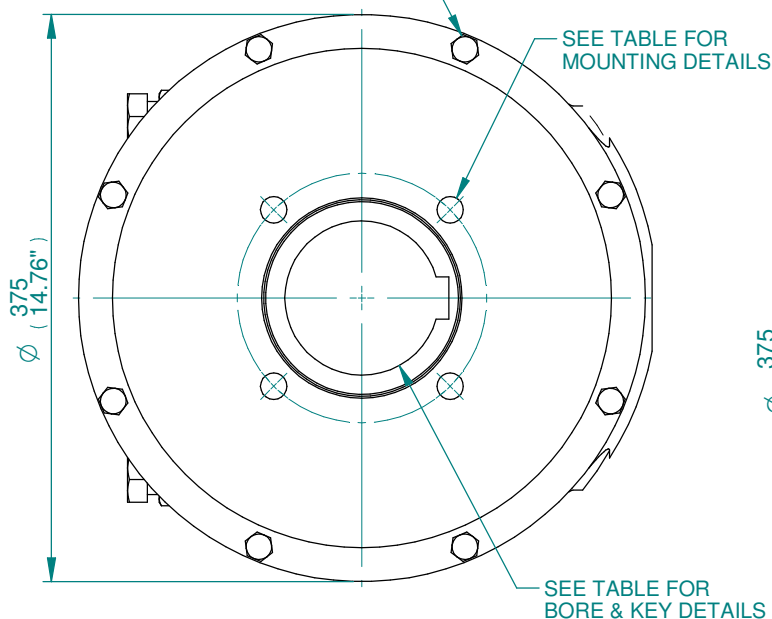

IW6 GEARBOX MOUNTING DETAILS FOR F16/FA16

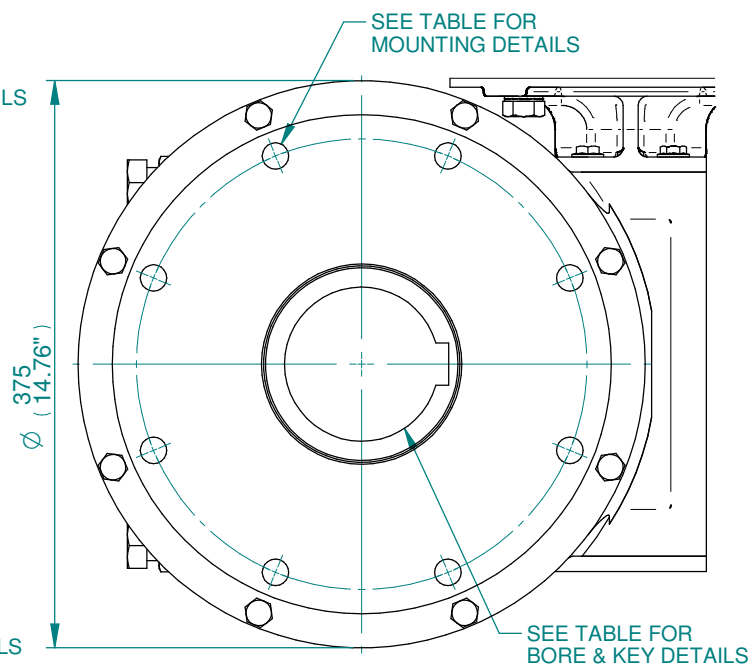

IW6 GEARBOX MOUNTING DETAILS FOR F25/FA25 & F30/FA30

BASEPLATE	X	Y	Z
STANDARD THICKNESS	70	113	139
FILLED THICKNESS	70	113	139
WAFER THICKNESS	93	136	162

STD	MAX BORE SQ KEY		MAX BORE RECTANGULAR KEY	
	BORE	KEY	BORE	KEY
BS4235	-	-	102	28X16
BS46	3.625"	1"SQ	3.75"	1"X3/4"
ANSI B17.1	3.75"	7/8"SQ	3.875"	1"X3/4"

BASEPLATE DETAILS		
TYPE	BASEPLATE	HOLE DETAILS (45° OFF CENTRES)
ISO F16	STANDARD	4 HOLES M20X20 (0.79") DEEP
		ON Ø165.00 (Ø6.49") P.C.
FA16	STANDARD	4 HOLES 3/4"UNCX20 (0.79") DEEP
		ON Ø165.00 (Ø6.49") P.C.
TYPE	BASEPLATE	HOLE DETAILS (22.5° OFF CENTRES)
ISO F25	STANDARD	8 HOLES M16X16 (0.63") DEEP
		ON Ø254.00 (Ø10.00") P.C.
FA25	STANDARD	8 HOLES 5/8"UNCX16 (0.63") DEEP
		ON Ø254.00 (Ø10.00") P.C.
ISO F30	FILLED AND WAFER	8 HOLES M20X30 (1.18") DEEP
		ON Ø298.00 (Ø11.73") P.C.
FA30	FILLED AND WAFER	8 HOLES 3/4"UNCX30 (1.18") DEEP
		ON Ø298.00 (Ø11.73") P.C.



Drawn	BHARAT	27-07-18
Checked	BHARAT	27-07-18
Approved	JOSE	27-07-18

**Title** DIMENSIONAL DRAWING, CKC30/60 & CKRC30/60, IW6, HIGH RATIO, CENTRONIK / 3 CONDUIT ENTRIES, SMALL MOTOR, STANDARD ORIENTATION.

This drawing and the information it contains are property of Rotork Controls Limited, and they will not be reproduced or disclosed, in whole or in part, without the prior written consent of Rotork.

<b>A4</b>	<b>Doc Number</b>	<b>Ver No</b>	<b>Scale</b>	<b>Sheet No</b>
	<b>A4W6RHBS00X</b>	<b>1</b>	<b>NTS</b>	<b>2 of 2</b>