

H  
G  
F  
E  
D  
C  
B  
A

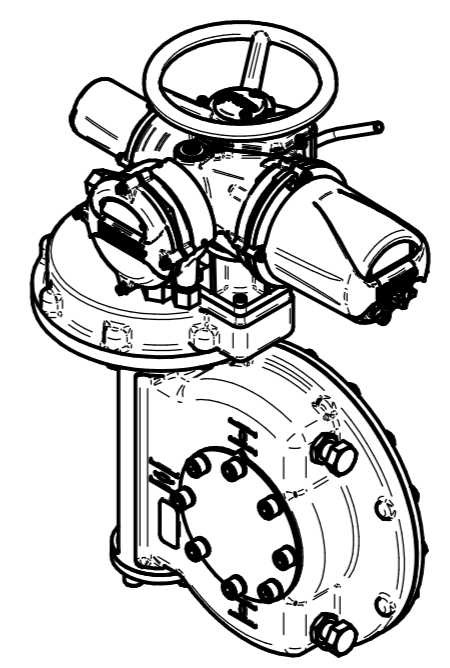
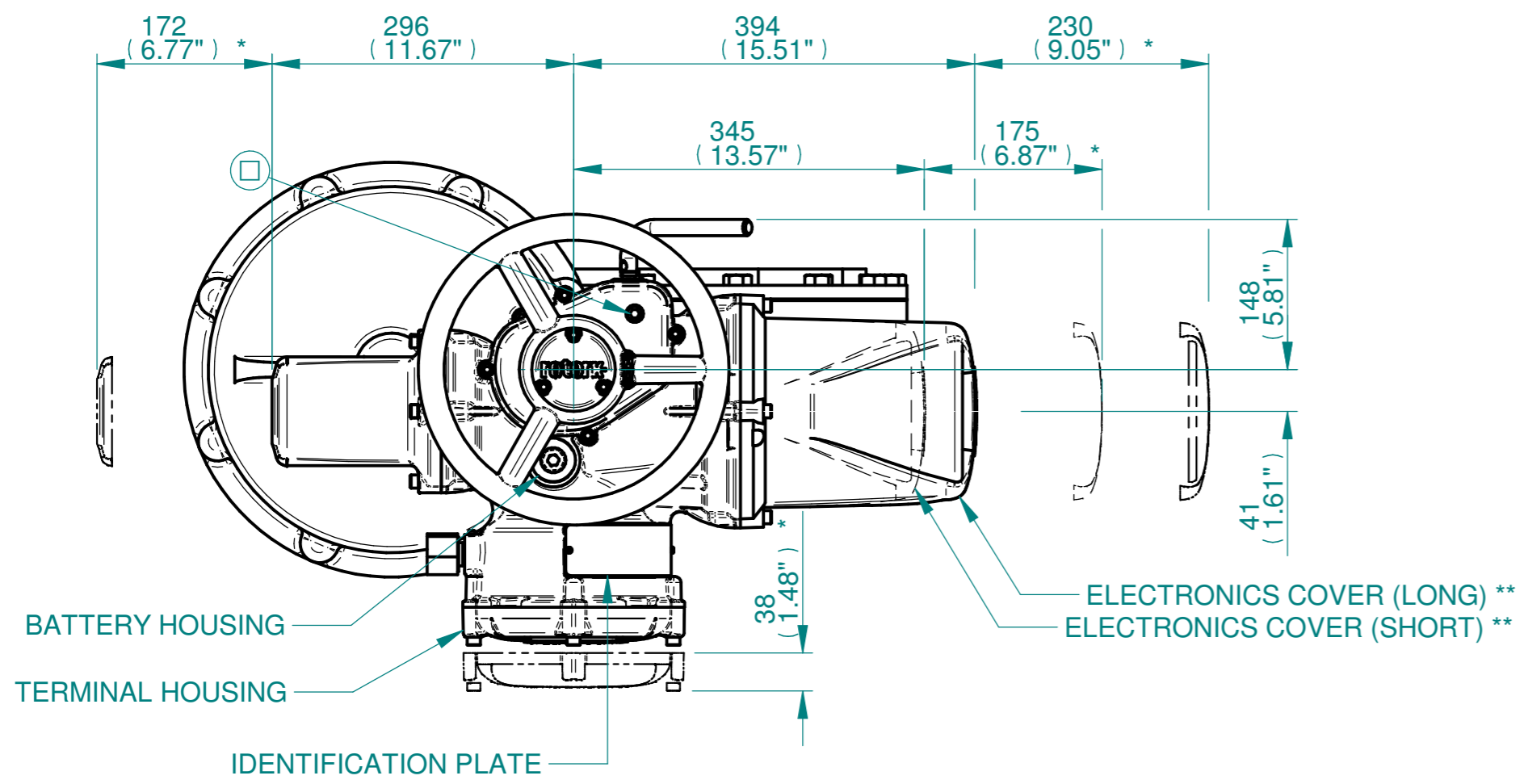

ISOMETRIC VIEW (SCALE 1:12)

**NOTES:**  
 :DIMENSIONS WITH "\*" INDICATE COVER REMOVAL ALLOWANCE  
 :ELECTRONICS COVER OPTION "\*" WILL VARY DEPENDING ON CONFIGURATION  
 :NETT WEIGHT = 253kg/558lbs  
 : = OIL FILLER/DRAIN PLUG  
 :THE INTERFACE PROVIDED FOR MOUNTING THE ACTUATOR OR SECOND STAGE GEARBOX ONTO THE VALVE SHOULD CONFORM TO GOOD ENGINEERING PRACTICES, ENSURING ADEQUATELY TOLERANCED LIMITS FOR PARALLELISM, PERPENDICULARITY AND CONCENTRICITY.  
 :ROTORK CANNOT BE HELD LIABLE FOR DAMAGE TO OUR EQUIPMENT CAUSED BY EXCESSIVE LOADING FROM COVER TUBES. (SEE ALSO PUB000-124)

**CONDUIT ENTRIES**

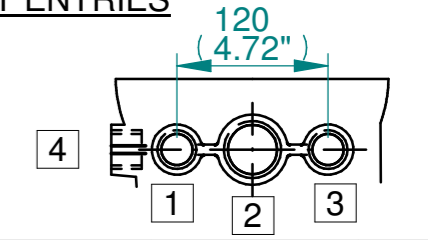

	Hole 1	Hole 2	Hole 3	Hole 4
Size	As Required	As Required	As Required	As Required
Plugged	As Required	As Required	As Required	As Required
Gland	As Required	As Required	As Required	As Required

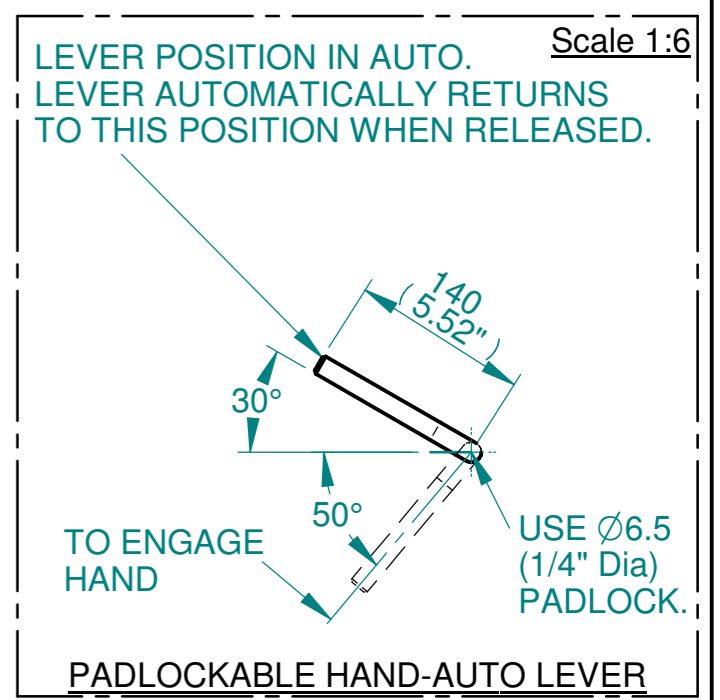
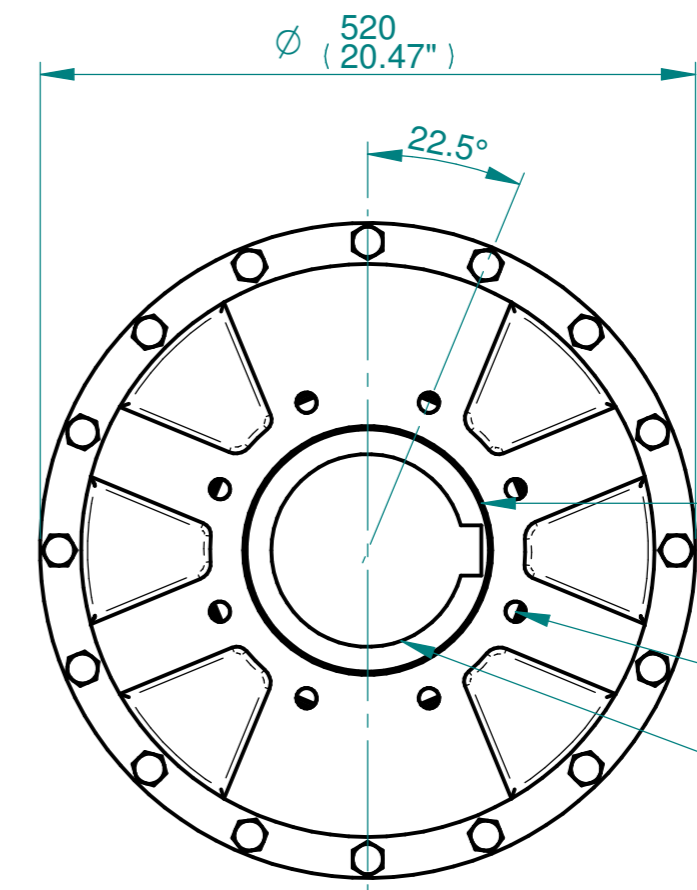
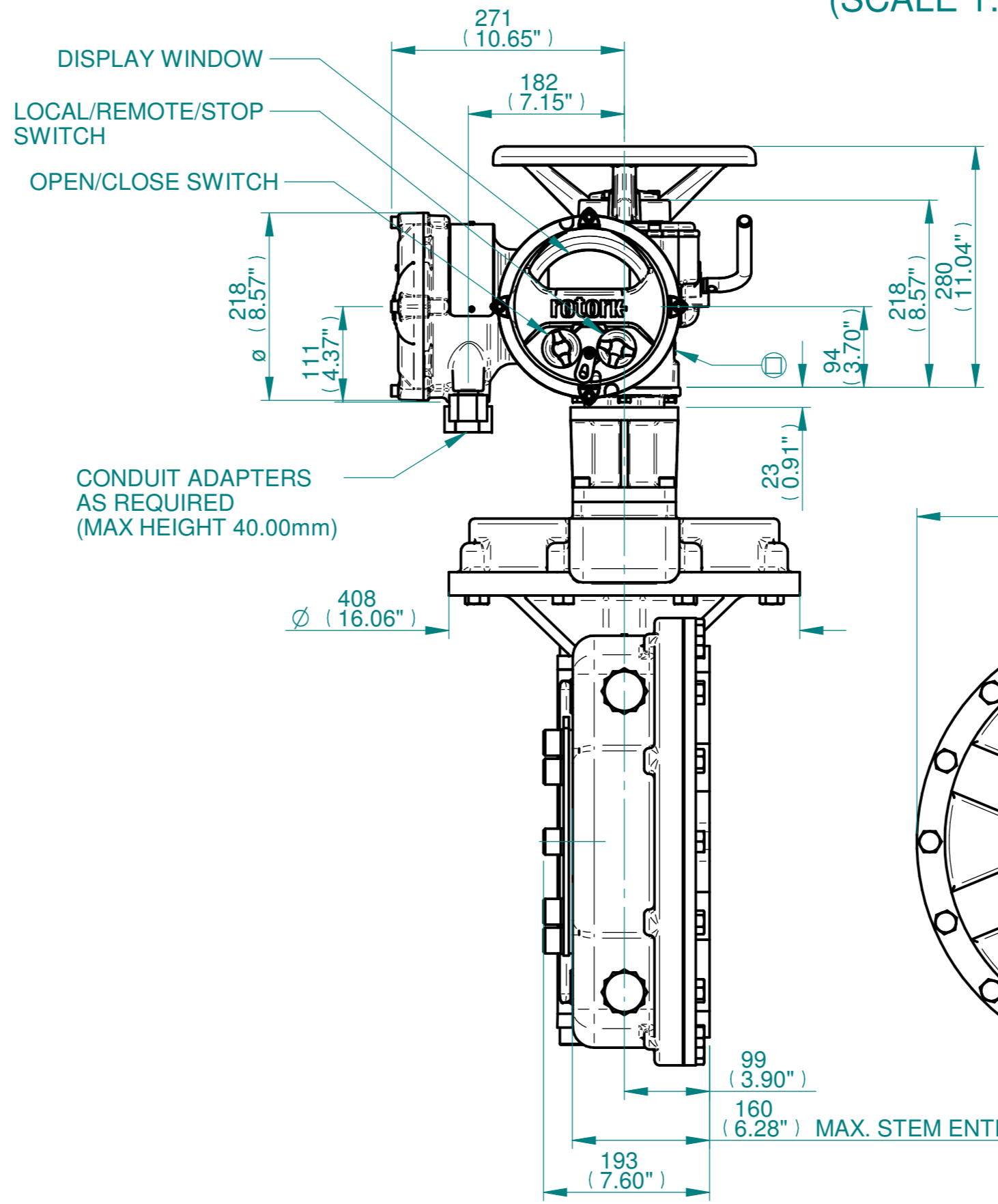
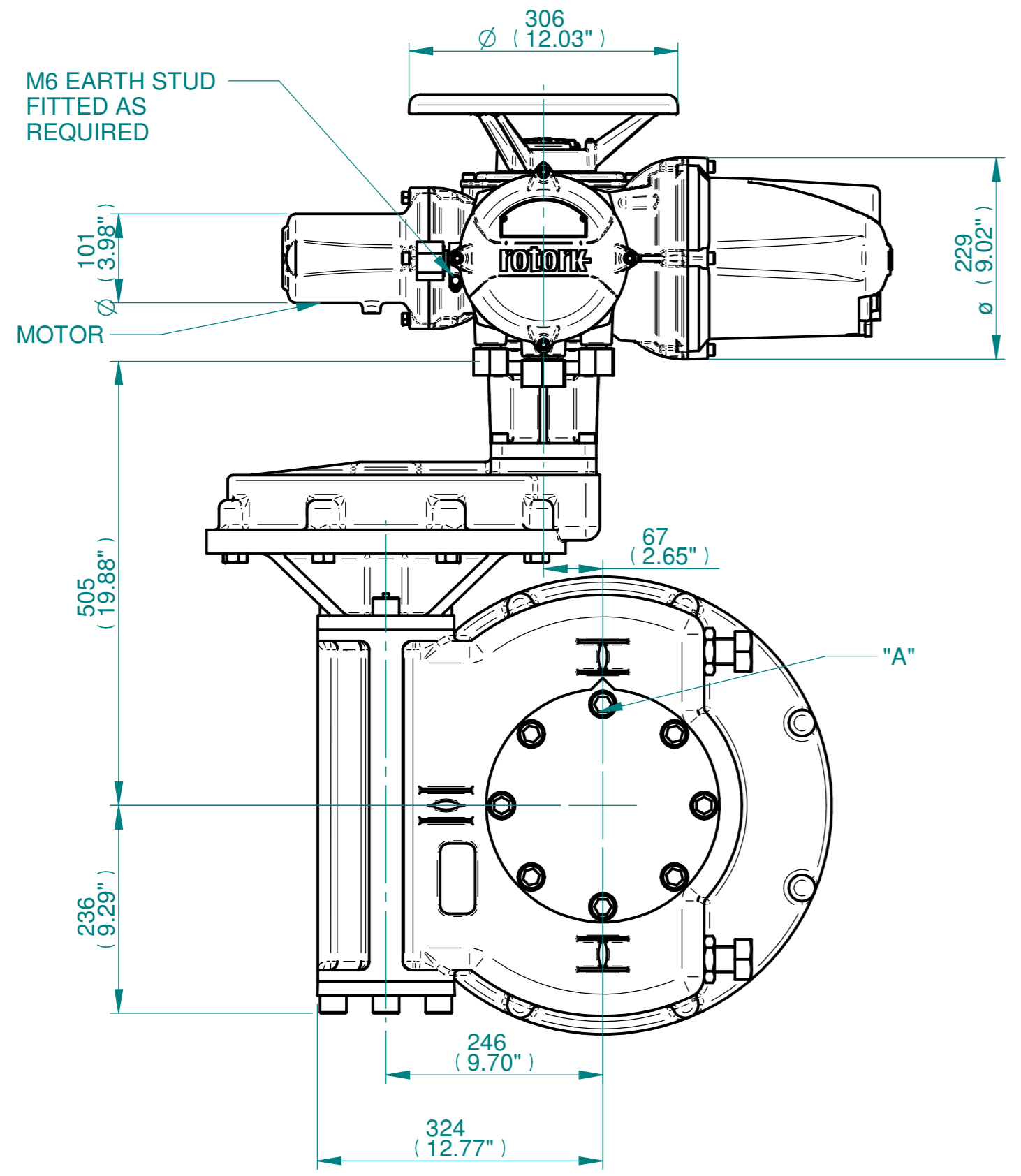

N.B. KEYWAY POS. CAN BE MOVED IN 45° STEPS BY REMOVING 8 SCREWS MARKED "A" AND ROTATING OUTPUT SLEEVE  
 SEE GEARBOX OUTPUT FLANGE OPTIONS TABLE  
 SEE MAXIMUM BORE & KEY TABLE

3D Models are available in various formats under the same drawing number

**rotork**  
 www.rotork.com  
 Rotork Controls Limited  
 Bath, BA1 3JQ, England.  
 Telephone 01225-733200

Actuator Size: IQ10/12/18 IW82RH/MOW82RH		Gearbox output flange options								Maximum Bore & Key			
Title	IQ10/12/18, TOP H/W, IW82RH/MOW82RH, F25/F30/F35/F40/FA25/FA30/FA35/FA40, Ratios 480:1 - 720:1 Installation Details	Designation	F25	F30	F35	F40	FA25	FA30	FA35	FA40	Key form	Ø Bore	Key size
Drawn	TED	No. Holes	8	8	8	8	8	8	8	8	Rectangle (BS4235)	157	40 X 22
Checked	NJC	Hole size	M16	M20	M30	M36	5/8" UNC	3/4" UNC	1" UNC	1-1/4" UNC	Rectangle (ANSI B17.1)	6"	1-1/2 X 1"
Date	18-AUG-14	PCD	254	298	356	406	10"	11-3/4"	14"	16"	Square (ANSI B17.1)	5-5/8"	1-1/2" SQ
Ref	SALES	Project Ref	QUOTATION										

Issue	Description
2	4 ENTRY CHANGE

Scale: 1:6 THIRD ANGLE PROJECTION

Drawing Number	Issue No	Sheet No
I11THWIW82RHSTD	2	1 of 1

1 2 3 4 5 6 7 8 9 10 11 12