

- NOTE:
1. GEARBOX RATIOS : 200, 240, 350 & 420:1
 2. GEARBOX BASEPLATE: F14/FA14, F16/FA16 & F25/FA25
 3. DIMENSIONS WITH "*" INDICATE COVER REMOVAL ALLOWANCE
 4. THE INTERFACE PROVIDED FOR MOUNTING THE ACTUATOR OR SECOND STAGE GEARBOX ONTO THE VALVE SHOULD CONFORM TO GOOD ENGINEERING PRACTICES, ENSURING ADEQUATELY TOLERANCED LIMITS FOR PARALLELISM, PERPENDICULARITY AND CONCENTRICITY.
 5. ROTORK CANNOT BE HELD LIABLE FOR DAMAGE TO OUR EQUIPMENT CAUSED BY EXCESSIVE LOADING FROM COVER TUBES, HANDWHEEL AND HAND LEVER.

PARAMETER	VALUE	DESCRIPTION
DRAWING TYPE	A	INSTALLATION DRAWING
ACTUATOR	4	CK(R)C30/60
GEARBOX1	W5	IW5
GEARBOX2	RH	HIGH RATIO
CENTRONIK / TERMINAL	E	CTK/LONG.DISC.
MECHANISM / MOTOR	S	STD.MECH./SMALL MOT.
HANDWHEEL / REAR / FRONT	0	STD.H.W./STD.REAR/STD.FRNT.
ORIENTATION	0	STD.ORIENT.

CK range	Drawn	JB	08-11-18
	Checked	JP	08-11-18
	Approved	JP	08-11-18

Title DIMENSIONAL DRAWING, CKC30/60 & CKRC30/60, IW5, HIGH RATIO, CENTRONIK/ LONG. DISC., SMALL MOTOR, STANDARD ORIENTATION.

This drawing and the information it contains are property of Rotork Controls Limited, and they will not be reproduced or disclosed, in whole or in part, without the prior written consent of Rotork.

A4	Doc Number	Ver No	Scale	Sheet No
	A4W5RHES00X	1	NTS	1 of 2

CONDUIT ENTRY HOLE		
Hole	Metric	NPT
A	4x M20	4x ¾"
B	2x M25	2x ¾"

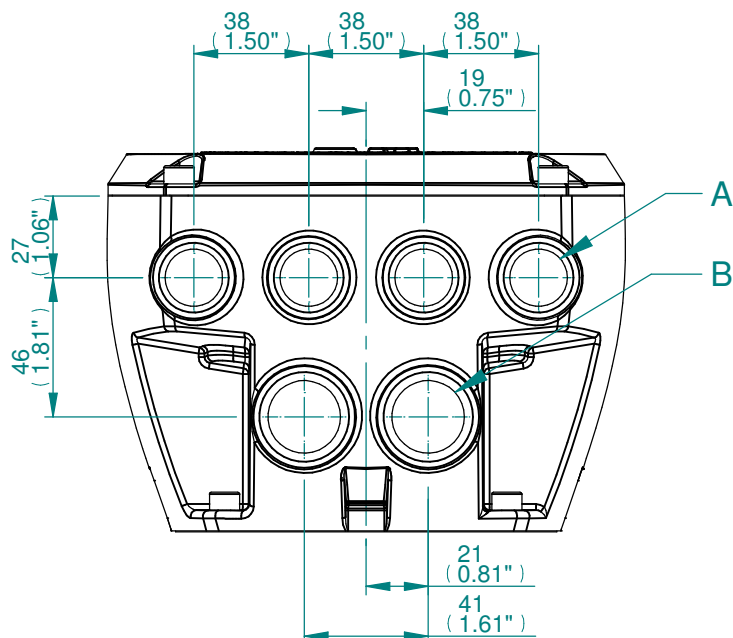

**DISCONNECT MODULE
CONDUIT ENTRIES**

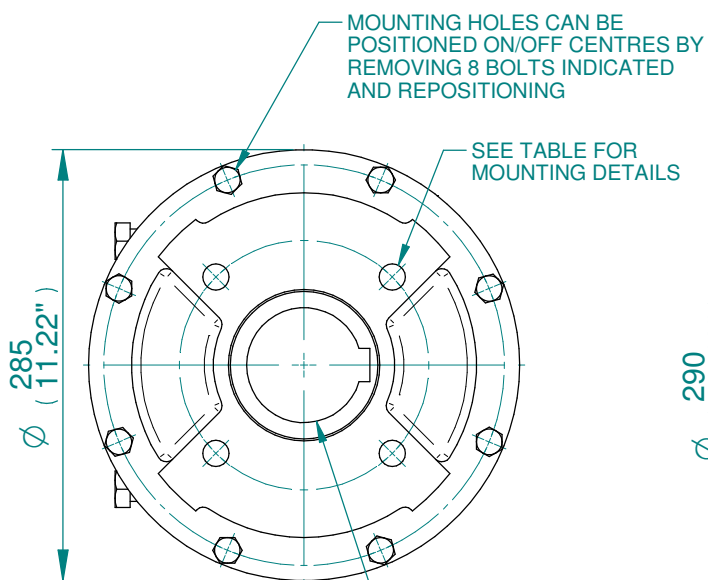

**IW5 GEARBOX
MOUNTING DETAILS
FOR F14/FA14 AND F16/FA16**

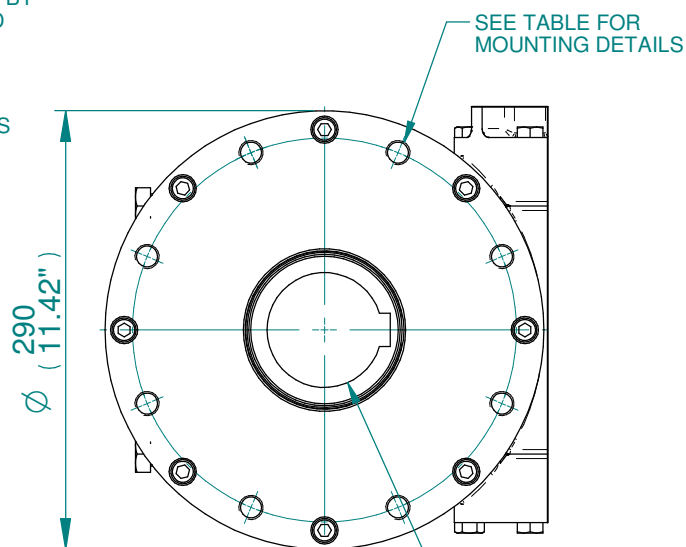

**IW5 GEARBOX
MOUNTING DETAILS
FOR F25/FA25**

BASEPLATE	X	Y	Z
STANDARD THICKNESS	65	110	128
FILLED THICKNESS	75	120	138
WAFER THICKNESS	101	146	164

STD	MAX BORE SQ KEY		MAX BORE RECTANGULAR KEY	
	BORE	KEY	BORE	KEY
BS4235	-	-	76.0	22X14
BS46	2.75"	3/4" SQ	3.00"	3/4"X1/2"
ANSI B17.1	2.75"	5/8" SQ	3.00"	3/4"X1/2"

BASEPLATE DETAILS		
TYPE	BASEPLATE	HOLE DETAILS (45° OFF CENTRES)
ISO F14	STANDARD	4 HOLES M16X16 (0.63") DEEP ON Ø140.0 (Ø5.51") P.C.
FA14		4 HOLES 5/8"UNCx16 (0.63") DEEP ON Ø139.7 (Ø5.50") P.C.
ISO F16		4 HOLES M20X16 (0.63") DEEP ON Ø165.0 (Ø6.50") P.C.
FA16		4 HOLES 3/4"UNCx16 (0.63") DEEP ON Ø165.0 (Ø6.50") P.C.
TYPE	BASEPLATE	HOLE DETAILS (22.5° OFF CENTRES)
ISO F25	FILLED AND WAFER	8 HOLES M16X16 (0.63") DEEP ON Ø254.0 (Ø10.00") P.C.
FA25		8 HOLES 5/8"UNCx16 (0.63") DEEP ON Ø254.0 (Ø10.00") P.C.



Drawn	JB	08-11-18
Checked	JP	08-11-18
Approved	JP	08-11-18

Title DIMENSIONAL DRAWING, CKC30/60 & CKRC30/60, IW5, HIGH RATIO, CENTRONIK/ LONG. DISC., SMALL MOTOR, STANDARD ORIENTATION.

A4	Doc Number	Ver No	Scale	Sheet No
	A4W5RHES00X	1	NTS	2 of 2