

A1A0002AX

PLUG-AND-SOCKET CONNECTOR LAYOUT



LEGENDS:

- M1** ELECTRIC MOTOR
- RL1** RELAY OUTPUT No1 (SETTABLE)
- RL2** RELAY OUTPUT No2 (SETTABLE)
- RL3** RELAY OUTPUT No3 (SETTABLE)
- RL4** RELAY OUTPUT No4 (SETTABLE)
- RL5** RELAY OUTPUT No5 (SETTABLE)
- RL6** RELAY OUTPUT No6 (SETTABLE)
- CS** CUSTOMER SUPPLY
- POSITIONER** POSITIONER IN/OUT ANALOG SIGNAL
- POSITIONER.LP** POSITIONER IN/OUT ANALOG SIGNAL. LOOP POWER
- MONIT.** MONITOR RELAY
- FIELDBUS** FIELDBUS CARD
- REMOTE** REMOTE INPUT CARDS
- ACTS** AUXILIARY CLOSE TORQUE SWITCH
- AOTS** AUXILIARY OPEN TORQUE SWITCH
- ACLS** AUXILIARY CLOSE LIMIT SWITCH
- AOLS** AUXILIARY OPEN LIMIT SWITCH
- IP1** VALVE MIDDLE TRAVEL POSITION SWITCH (No 1)
- IP2** VALVE MIDDLE TRAVEL POSITION SWITCH (No 2)
- IP3** VALVE MIDDLE TRAVEL POSITION SWITCH (No 3)
- IP4** VALVE MIDDLE TRAVEL POSITION SWITCH (No 4)
- CPT** CURRENT POSITION TRANSMITTER
- CTT** CURRENT TORQUE TRANSMITTER
- CPT.LP** CURRENT POSITION TRANSMITTER, LOOP POWER
- CTT.LP** CURRENT TORQUE TRANSMITTER, LOOP POWER
- CTS** CLOSE TORQUE SWITCH
- OTS** OPEN TORQUE SWITCH
- CLS** CLOSE LIMIT SWITCH
- OLS** OPEN LIMIT SWITCH
- TRM** THERMAL PROTECTION DEVICE (MOTOR WIND.)
- HTI** ANTI-CONDENSATION HEATER
- BLK** BLINKER SWITCH
- POT** POTENTIOMETER (VALVE POSITION SIGNAL)

NOTES:

1. THE TERMINAL PLAN SHOWS THE MULTI-TURN ELECTRIC ACTUATOR IN INTERMEDIATE POSITION, ACTUATOR CLOSES VALVE CLOCKWISE.
2. SEE ACTUATOR USER MANUAL AND DATASHEETS FOR TECHNICAL DATA, PARAMETERS AND DESCRIPTION OF THE ACTUATOR ELECTRIC AND ELECTRONIC EQUIPMENT.
3. THE USER MUST FIT A CLASS 10 OVERLOAD RELAY. THE RELAY MUST BE SIZED ACCORDING TO THE OVERCURRENT PROT. DEVICE SETTING VALUE FOR THE MOTOR.
4. REFER TO THE MOTOR DATA SHEET FOR THIS VALUE. THE OVERLOAD RELAY MUST BE SIZED TO ENSURE THAT IT TRIPS WITHIN 10 SECONDS IN A FAULT CONDITION.
5. THE USER MUST COMPLETE A RISK ASSESSMENT AND IMPLEMENT WHATEVER MEASURES ARE REQUIRED TO ENSURE THAT THE RESULTANT SYSTEM COMPLIES WITH ALL APPLICABLE LEGISLATION.

PARAMETER	VALUE	DESCRIPTION
TYPE	A	MULTI-TURN ELECTRIC ACTUATOR WITH ATRONIK (MECHANICAL SWITCH MECH.)
MAIN POWER SUPPLY	1	A.C. SINGLE PHASE
EXTRA CARD No 1	A	4 EXTRA RELAY CARD
EXTRA CARD No2	0	NO (WITHOUT)
MOTOR STARTER	0	REVERSIBLE CONTACTORS (STANDARD)
CUSTOMER SUPPLY & BLUETOOTH	0	24VDC±20% AT MAX.POW.OUTPUT 5W
BACKUP SUPPLY & HEATER	2	NO BACKUP SUPPLY, HEATER INCLUDED
EXTRA SWITCH	A	VISUAL INDICATOR DISC

ISSUE	DESCRIPTION	DATE	ISSUE	DESCRIPTION	DATE
A	PRE RELEASE	26-09-18	C		
B	Actuator Terminal Plan. M10100A was D10100A	21-12-18	D		

SHEET 1/2	DATE	SIGN.	TERMINAL PLAN	
MADE BY	25-09-2018	TAMIL	WD CKA-CKRA ATK., MSM, 1PH, AREL, NOEX2, CTOR, CS24, NOBK-HT, IMP	
CHECKED	25-09-2018	BHARAT		
APPROVED	24/09/2018	JOSE		

CK <small>large</small>	FORMAT	DRAWING N°
	A4	A1A0002AX - B

This drawing and the information it contains are property of Rotork Controls Limited, and they will not be reproduced or disclosed, in whole or in part, without the prior written consent of Rotork.

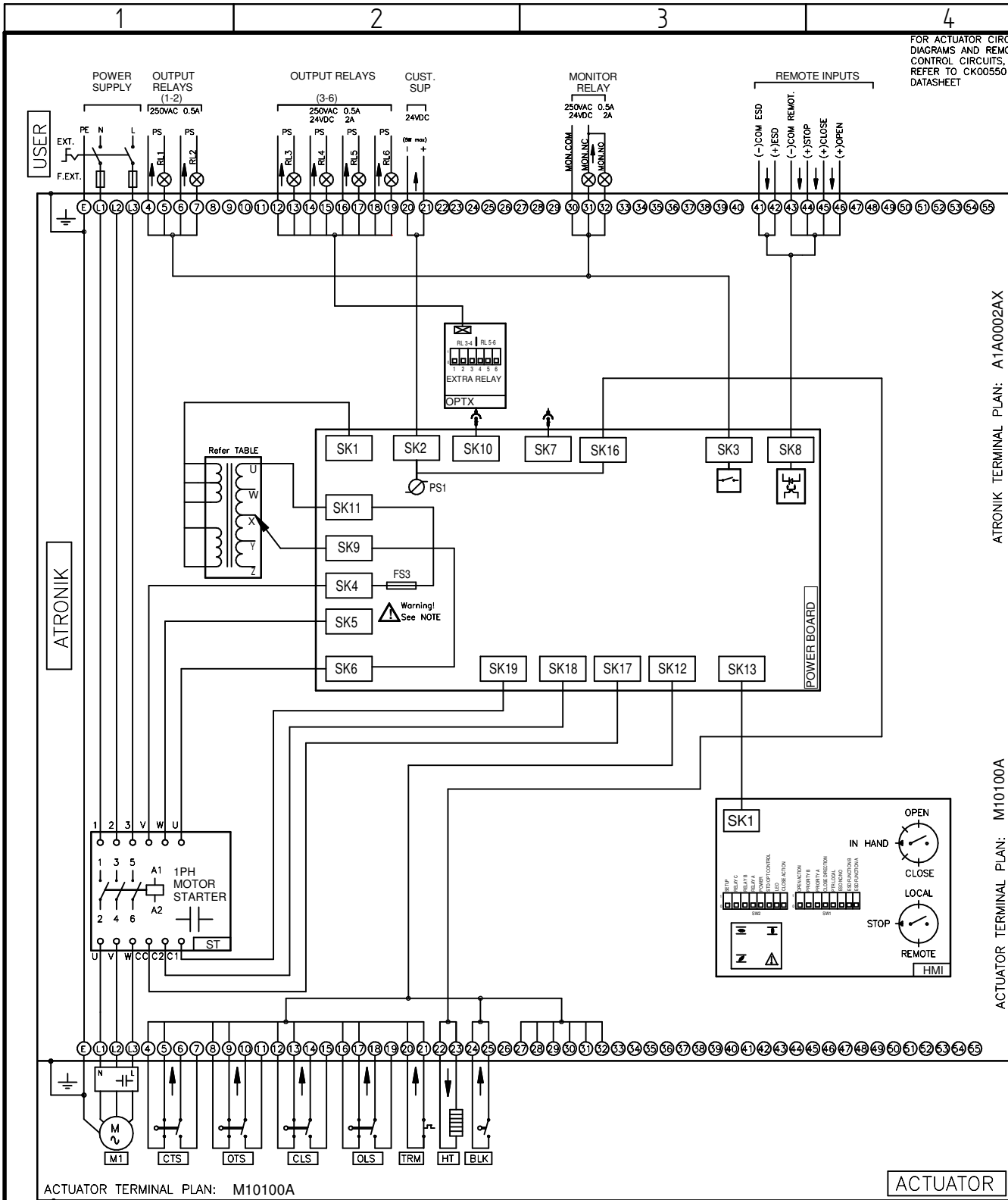

FOR ACTUATOR CIRCUIT DIAGRAMS AND REMOTE CONTROL CIRCUITS, REFER TO CK00550 DATASHEET

ATRONIK TERMINAL PLAN: A1A0002AX

ACTUATOR TERMINAL PLAN: M10100A

ACTUATOR TERMINAL PLAN: M10100A

ACTUATOR

⚠ WARNING: REFER TO SAFE USE AND INSTALLATION MANUAL OR CK00550 DATASHEET FOR APPROVED FUSES.
 FS3: SIBA, 70-065-65 1A, 500V, 6.3mmx32mm

TRANSFORMER TAPPING OPTIONS

PRIMARY TAP NOMINAL VOLTAGE (VAC 50/60Hz)			
TAP	TYPE 1	TYPE 2	TYPE 3
W	115	380	500
X	208	415	575
Y	220	440	600
Z	240	480	690

- THE TERMINAL PLAN SHOWS THE MULTI-TURN ELECTRIC ACTUATOR IN INTERMEDIATE POSITION, ACTUATOR CLOSES VALVE CLOCKWISE.
- REFER TO SAFE USE AND INSTALLATION MANUAL AND DATASHEETS FOR TECH. DATA, PARAMETERS AND DESCRIPTION OF THE ACTUATOR ELECTRIC AND ELECTRONIC EQUIPMENT.
- ACTUATORS WITH SOLID STATE STARTER (SSS), THE ACTUATOR MUST BE PROTECTED USING SUITABLE RATED HIGH SPEED SEMI-CONDUCTOR FUSES ON THE INCOMING SUPPLY.
- THE USER MUST CONDUCT A RISK ASSESSMENT, AND IMPLEMENT WHATEVER EXTRA SAFETY MEASURES ARE REQUIRED, TO ENSURE THAT THE RESULTANT SYSTEM COMPLIES WITH THE LOW VOTAGE DIRECTIVE, AND ANY OTHER LEGISLATION IN FORCE AT THE INSTALLATION SITE.
- REFER INSTALLATION MANUAL TO CONFIGURE SW1 AND SW2

ISSUE	DESCRIPTION	DATE	ISSUE	DESCRIPTION	DATE
A	PRE RELEASE	26-09-18	C		
B	Actuator Terminal Plan M10100A was D10100A	21-12-18	D		

SHEET 2/2	DATE	SIGN.	WIRING DRAWING WD CKA-CKRA ATK, MSM, 1PH, AREL, NOEX2, CTOR, CS24, NOBK-HT, IMP	This drawing and the information it contains are property of Rotork Controls Limited, and they will not be reproduced or disclosed, in whole or in part, without the prior written consent of Rotork.	
MADE BY	25-09-2018	TAMIL			
CHECKED	25-09-2018	BHARAT		A4	A1A0002AX - B
APPROVED	24/09/2018	JOSE			

A
B
C
D
E
F