

CIRCUIT DRAWN WITH POWER SUPPLY OFF

FOR TYPICAL REMOTE CONTROL
DETAILS, SEE DOCUMENT
RWS100

FUSE FS1 -20A ATO FAST ACTING
FUSE FS2 500mA ANTI-SURGE
REFER TO SHEET 2 FOR NOTES
& OPTION PCB'S IF FITTED

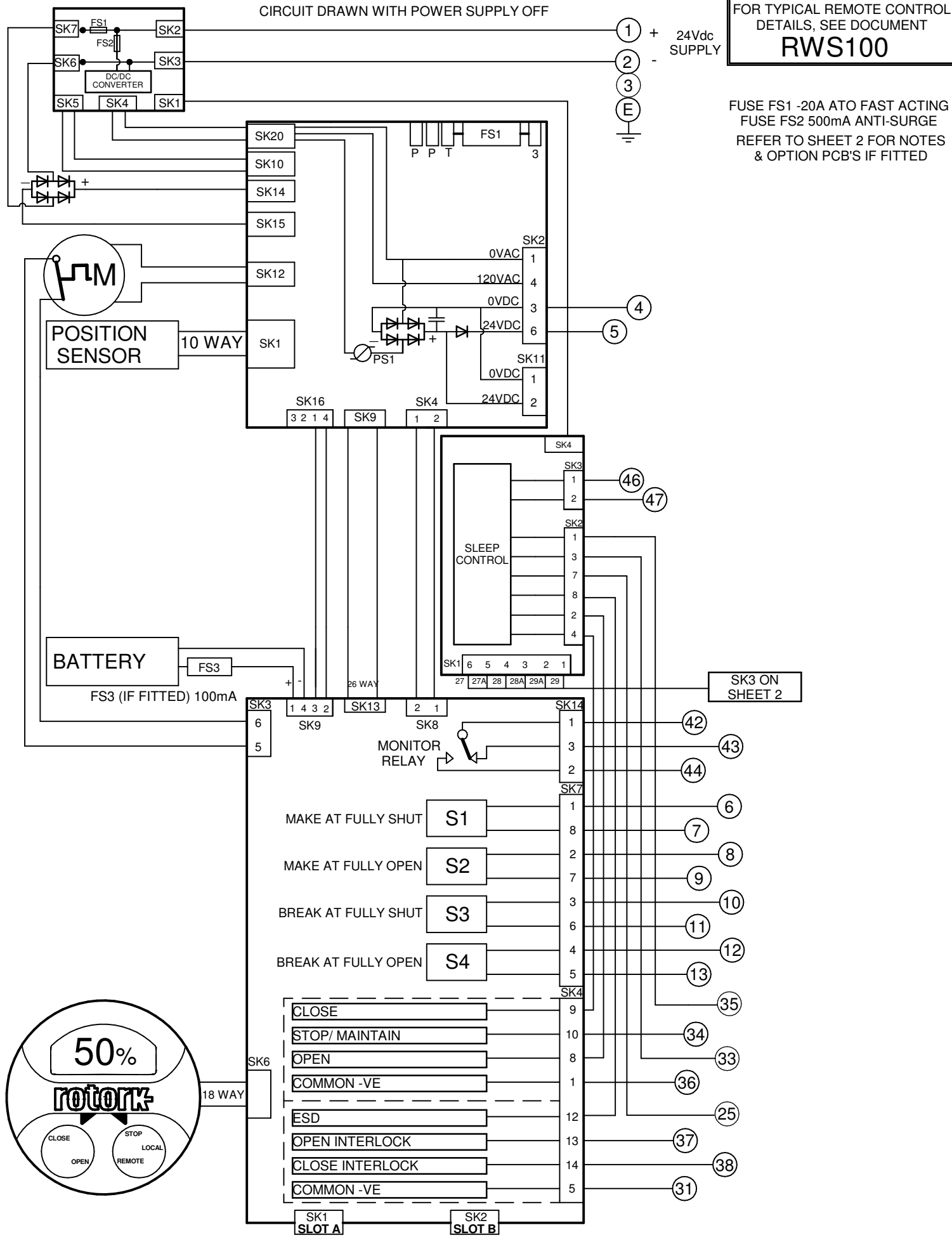

Iss	Date	Chkd	Revision Details
1	121218	JC1	First Issue.
2	110719	PMJ	PUB002-065 WAS -039

www.rotork.com

ROTORK CONTROLS LTD
BATH, BA1 3JQ
ENGLAND
Tel:01225-733200

ROTORK CONTROLS INC
ROCHESTER
NY 14624, USA
Tel:585-247-2304

IQTM DC SOLAR + MODBUS

Drawn by: PJW
Date : 121218
Base WD: 450M2000
Job No : - -
MI No : - -

Circuit Diagram Number
450M2000

Issue No
2

Sheet
1
of 2

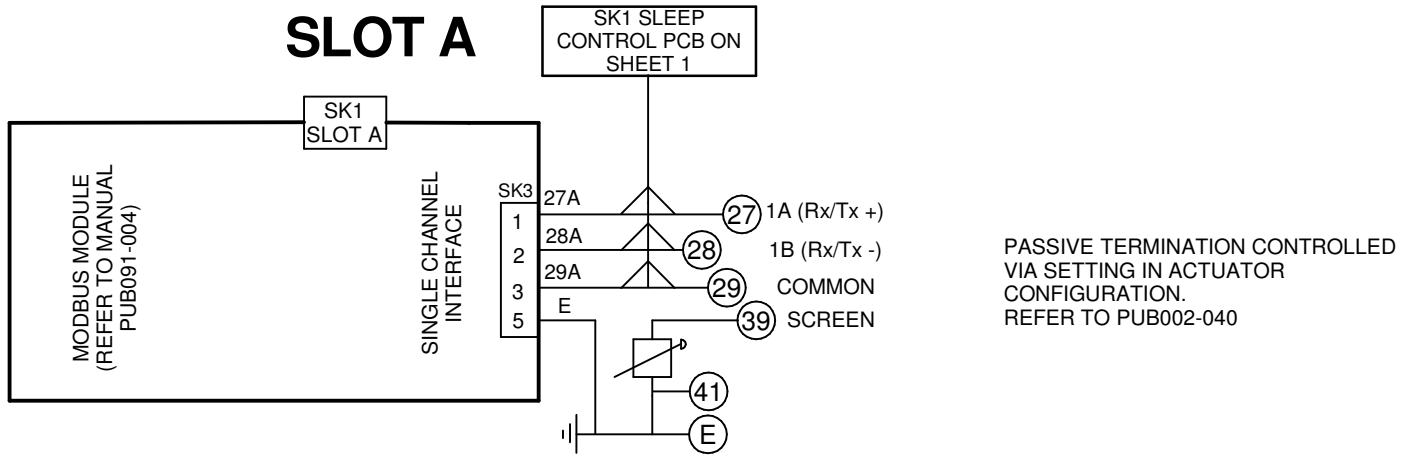

MODBUS RS485 SIGNAL LINES REQUIRE EXTERNAL ACTIVE BIASING TO BE PROVIDED AT ONE LOCATION FOR THE WHOLE BUS SEGMENT. REFER TO PUB091-004.

NOTES

1.FUSES:

- PS1 is a self-resetting fuse.
- Refer to publication PUB002-065 for approved fuses FS1 and FS2.
- Actuator rated voltage specified on nameplate. Voltage tolerance +/-10% applies for rated torque performance; duty cycle is not guaranteed.

2.REMOTE CONTROL:

- For typical remote control circuits refer to:
 - RWS indicated or PUB002-041.
- For DC control connect -ve to terminal 36.
- (For negative switch / positive common, refer to RWS indicated).
- Control signal threshold voltages:
 - DC: "on" $\geq 16\text{Vdc}$ / "off" $\leq 8\text{Vdc}$, max 60Vdc.
- Control signal duration to be 100ms minimum.
- Maximum current drawn from remote control signals is:
 - 8mA at 24Vdc.
- Supply provided on terminals 4 & 5:
 - Intended for remote control.
 - Max external load 5W at 24Vdc

5.DC:

- Default for sleep mode is ENABLE.
- To disable sleep mode connect 5 to 46 & 4 to 47.
- Actuator will remain powered up at all times while supply is present.
- 24VDC will be lost when in sleep mode.
- If customer supply is needed to wake actuator link LK1 must be moved to S for maintained customer supply.

3.INDICATION:

- For typical position, status and alarm indication see PUB002-041.
- “S” contacts are user configurable and are shown in their default setting.
- Refer to PUB002-040 for functions and configuration instructions.
- Monitor Relay indicates actuator availability for remote control (shown “unavailable”). It can be configured to exclude local/remote selection.
- Refer to PUB002-040 for monitored functions and configuration instructions.
- Voltage applied to indication contacts must not exceed 150Vac
- Individual Switch current must not exceed 3.5A inductive, 5A resistive and no more than 8A in total for all 4 contacts.

4.BATTERY:

- Battery maintains local and remote “S” contact indication only.
- Refer to installation manual for approved replacement battery types.