

CIRCUIT DRAWN WITH  
POWER SUPPLY OFF

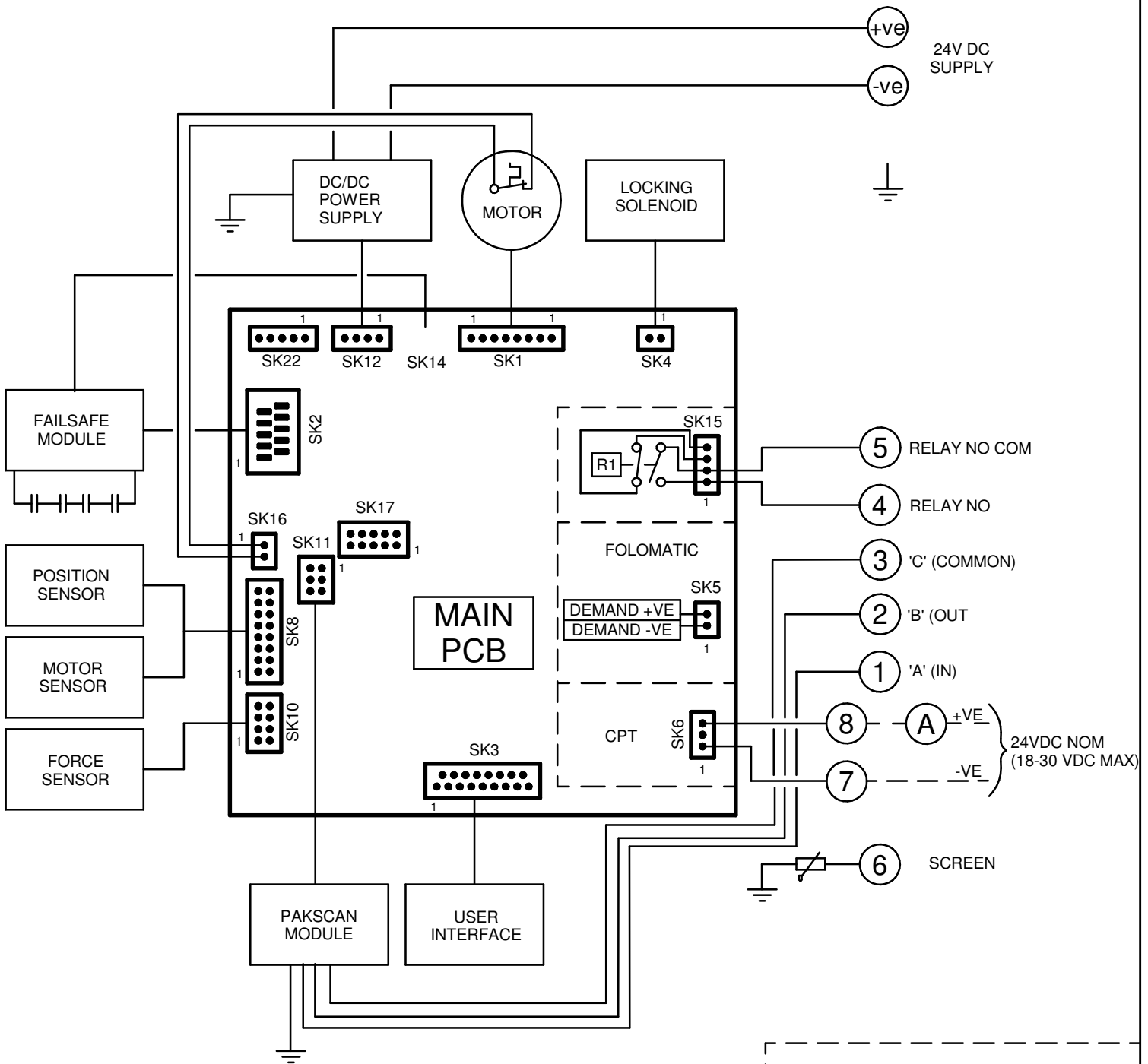

RELAY R1 CAN BE CONFIGURED TO INDICATE ANY ONE OF THE FOLLOWING:-

- 0 DISABLED
- 1 REMOTE CONTROL AVAILABLE
- 2 FAULT
- 3 FULLY OPEN
- 4 FULLY CLOSED
- 5 FORCE TRIP OPENING
- 6 FORCE TRIP CLOSING
- 7 FORCE TRIP ANY POSITION
- 8 FAILSAFE OPERATION

UPS SOCKET FOR  
CVL5000 / CVQ6000



WHEN MANUAL  
OVERRIDE IS FITTED  
MOTOR DISABLE  
SWITCH FITTED IN  
SERIES WITH  
THERMOSTAT (SK16)

Iss	Date	Chkd	Revision Details
1	180319 JC1	PJW	First Issue.

[www.rotork.com](http://www.rotork.com)

ROTORK CONTROLS LTD  
BATH, BA1 3JQ  
ENGLAND  
Tel:01225-733200

ROTORK CONTROLS INC  
ROCHESTER  
NY 14624, USA  
Tel:585-247-2304

CVA, D/C, N/O CONTACT, LOCKING  
SOLENOID, MOR, PSCAN & FAILSAFE.

Drawn by: JC1  
Date : 180319  
Base WD: C32-20  
Job No : --  
MI No : --

Circuit Diagram No  
**C32-20**  
Issue No  
**1**