

ISOMETRIC VIEW  
1:10

**NOTES:**  
 : DIMENSIONS WITH "" INDICATE COVER REMOVAL ALLOWANCE  
 : ELECTRONICS COVER OPTION "" WILL VARY DEPENDING ON CONFIGURATION  
 : NETT WEIGHT = 145kg/320lbs  
 : = OIL FILLER/DRAIN PLUG  
 : THE INTERFACE PROVIDED FOR MOUNTING THE ACTUATOR OR SECOND STAGE GEARBOX ONTO THE VALVE SHOULD CONFORM TO GOOD ENGINEERING PRACTICES, ENSURING ADEQUATELY TOLERANCED LIMITS FOR PARALLELISM, PERPENDICULARITY AND CONCENTRICITY.  
 : ROTORK CANNOT BE HELD LIABLE FOR DAMAGE TO OUR EQUIPMENT CAUSED BY EXCESSIVE LOADING FROM COVER TUBES. (SEE ALSO PUB000-124)

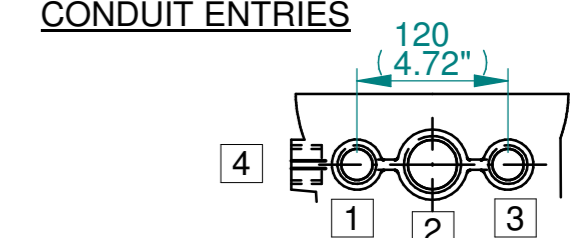

	Hole 1	Hole 2	Hole 3	Hole 4
Size	As Required	As Required	As Required	As Required
Plugged	As Required	As Required	As Required	As Required
Gland	As Required	As Required	As Required	As Required

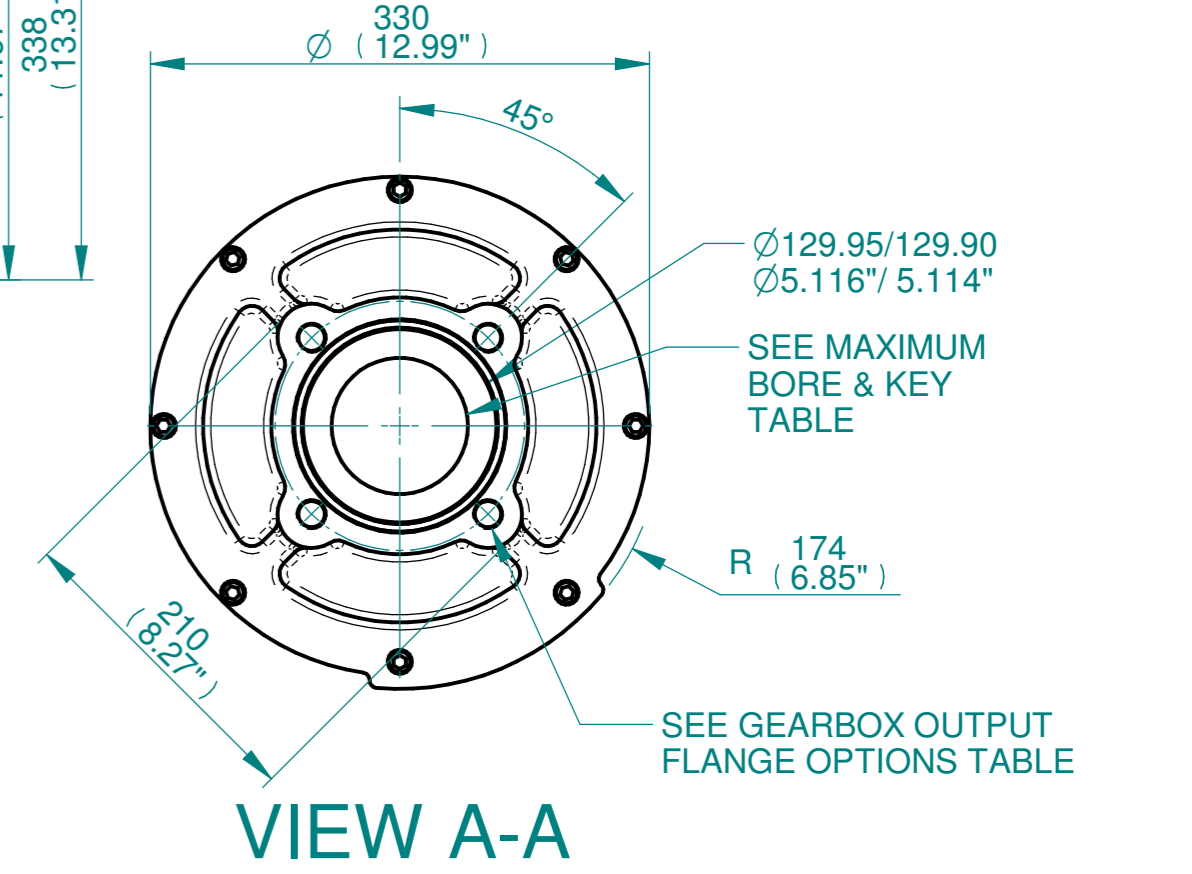
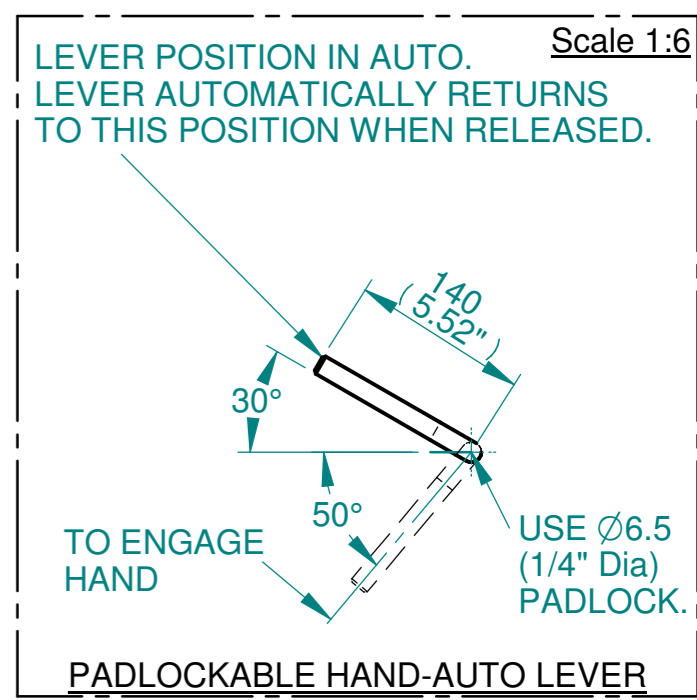
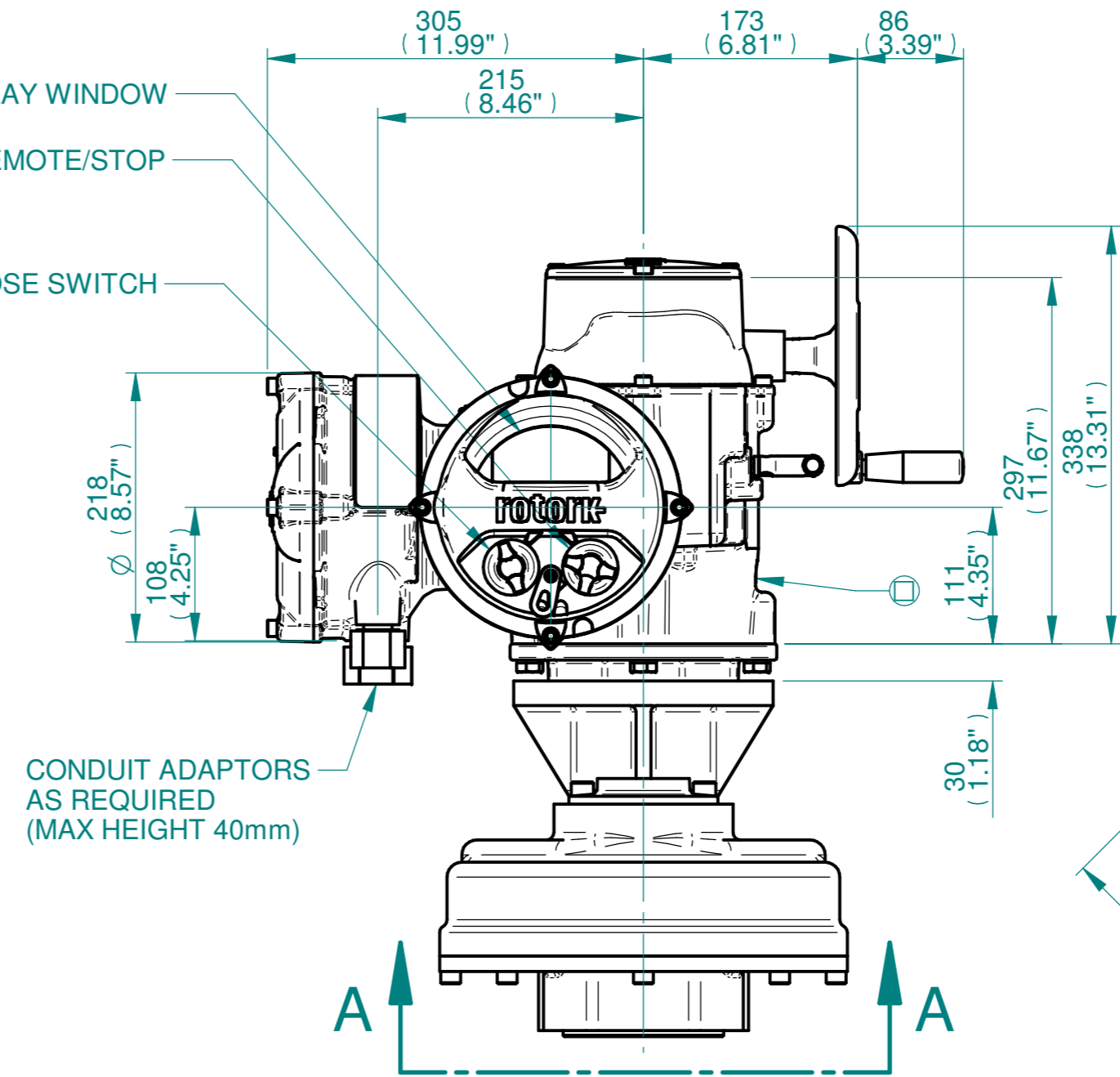
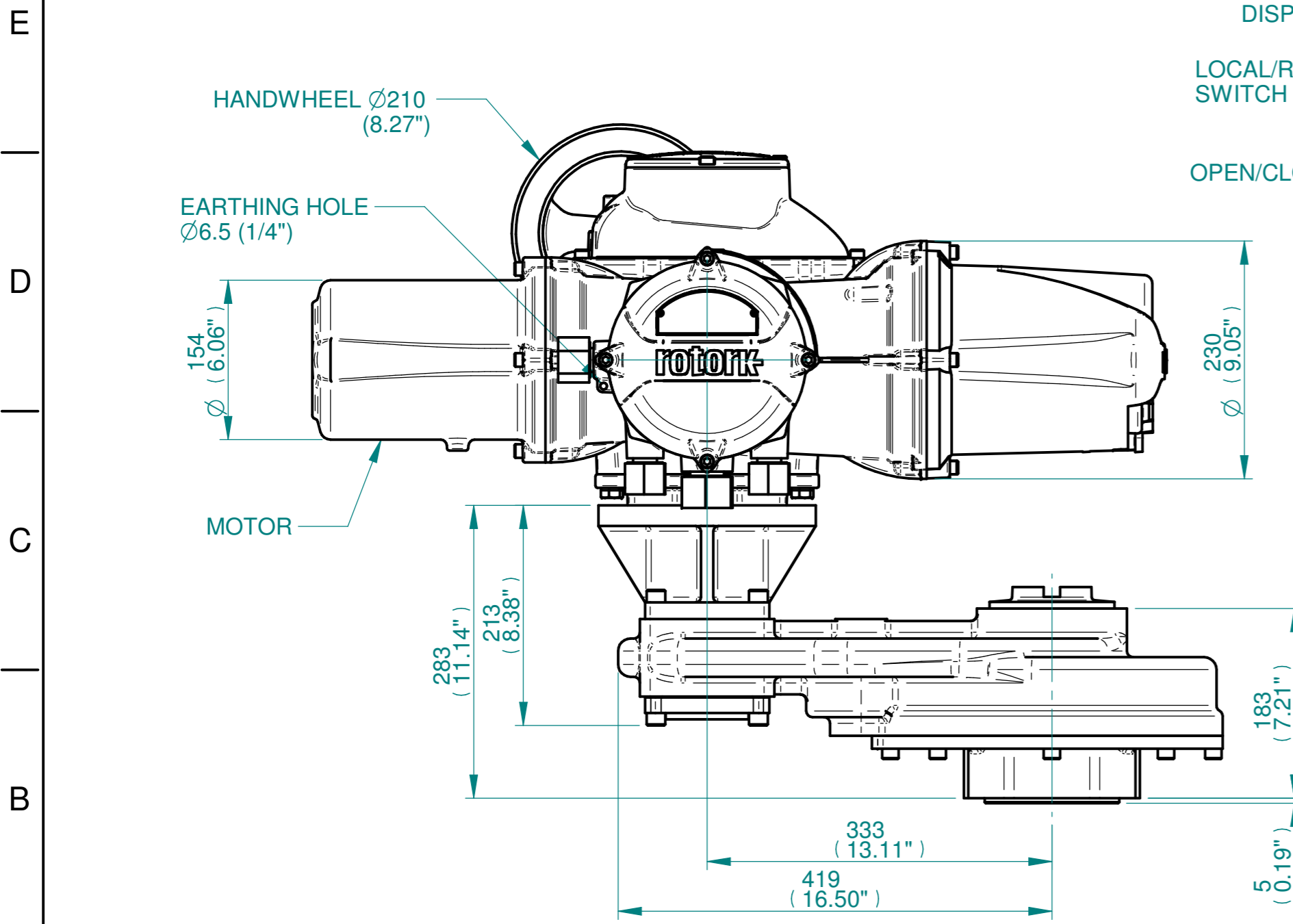

3D Models are available in various formats under the same drawing number

Actuator Size: IQ35, IS8		Gearbox output flange options								Maximum Bore & Key			
<b>rotork</b> www.rotork.com Rotork Controls Limited Bath, BA1 3JQ, England. Telephone 01225-733200	Title IQ35, SIDE HANDWHEEL, IS8, F16, FA16, Ratios 4:1,6:1,8:1,10:1,12:1 15:1 Installation Details	Designation	F16	-	-	-	FA16	-	-	-	Key form	Ø Bore	Key size
	Drawn DH Checked JBA Date JAN 19	No. Holes	4	-	-	-	4	-	-	-	Rectangle (BS4235)	68	20 x 12
	Ref SALES Project Ref QUOTATION	Hole size	M20	-	-	-	3/4" UNC	-	-	-	-	-	-
		PCD	165	-	-	-	61/2"	-	-	-	-	-	-

Issue	Description
1	FIRST ISSUE

Scale: 1:5 THIRD ANGLE PROJECTION

Drawing Number	Issue No	Sheet No
I13SHWIS8STD	1	1 of 1