

H  
G  
F  
E  
D  
C  
B  
A

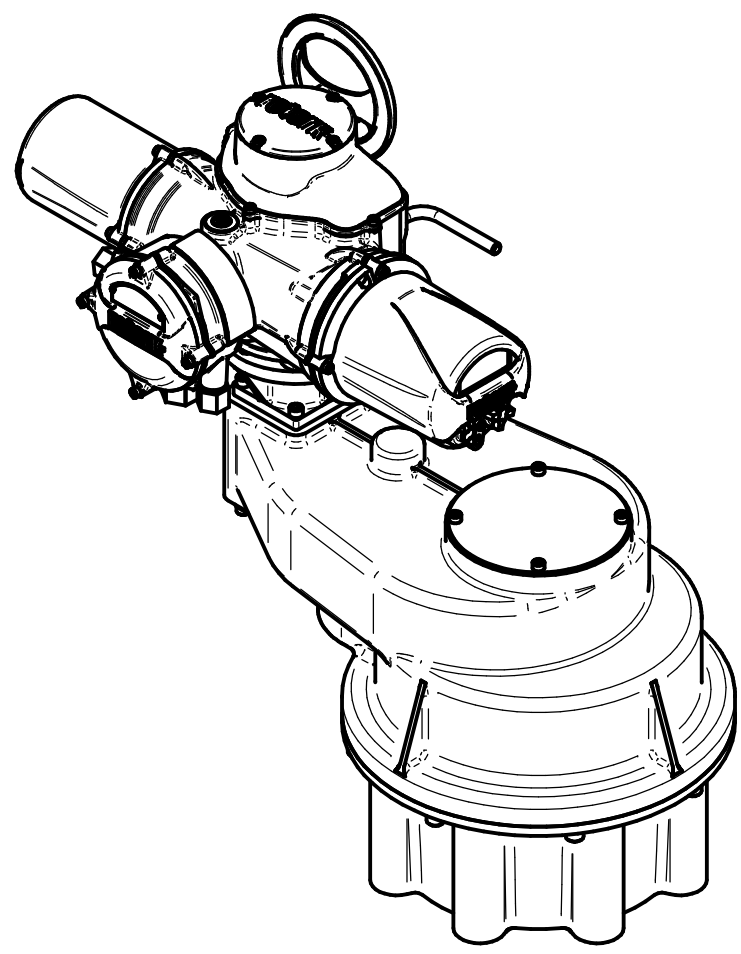

ISOMETRIC VIEW  
1:10

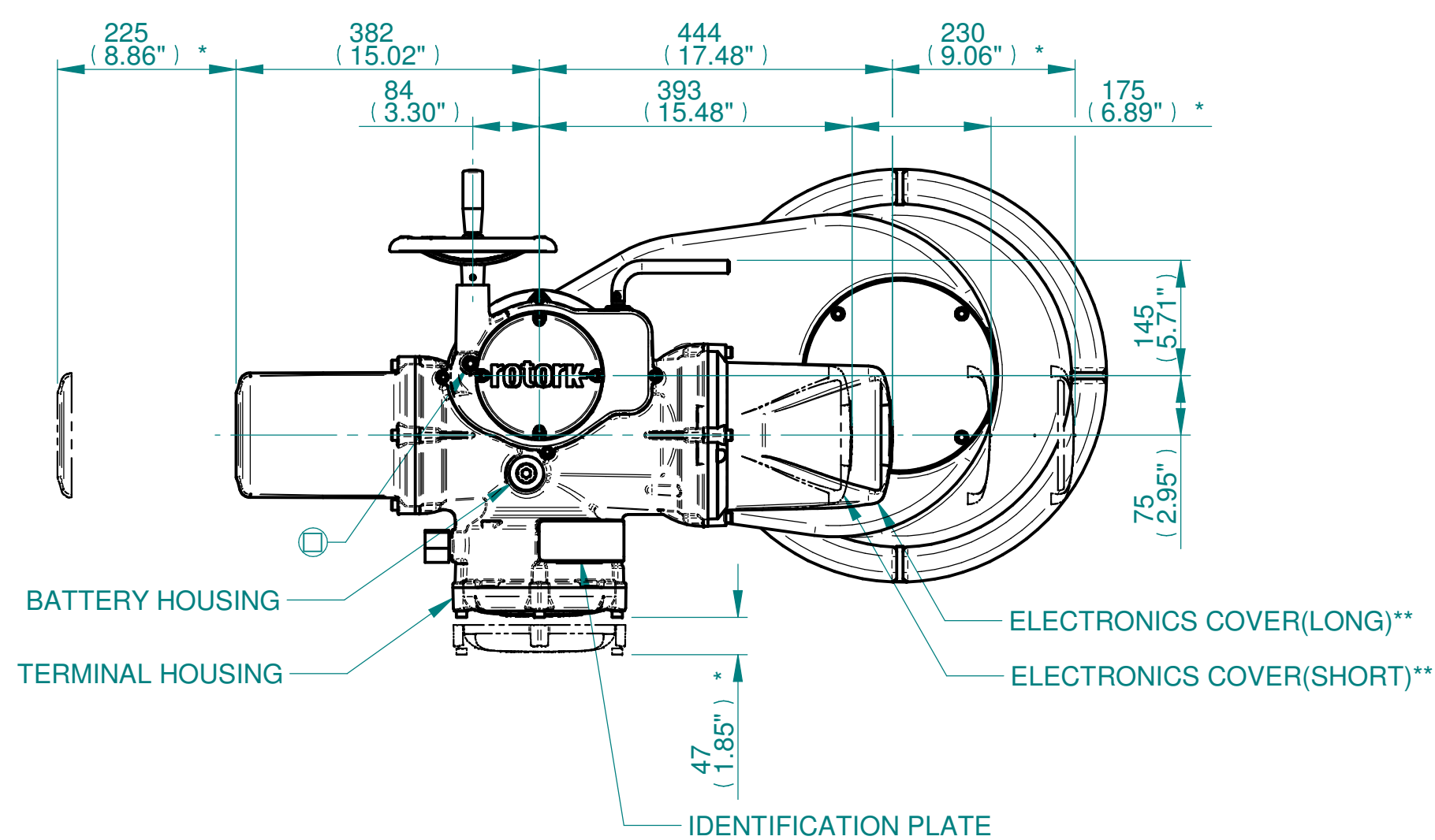
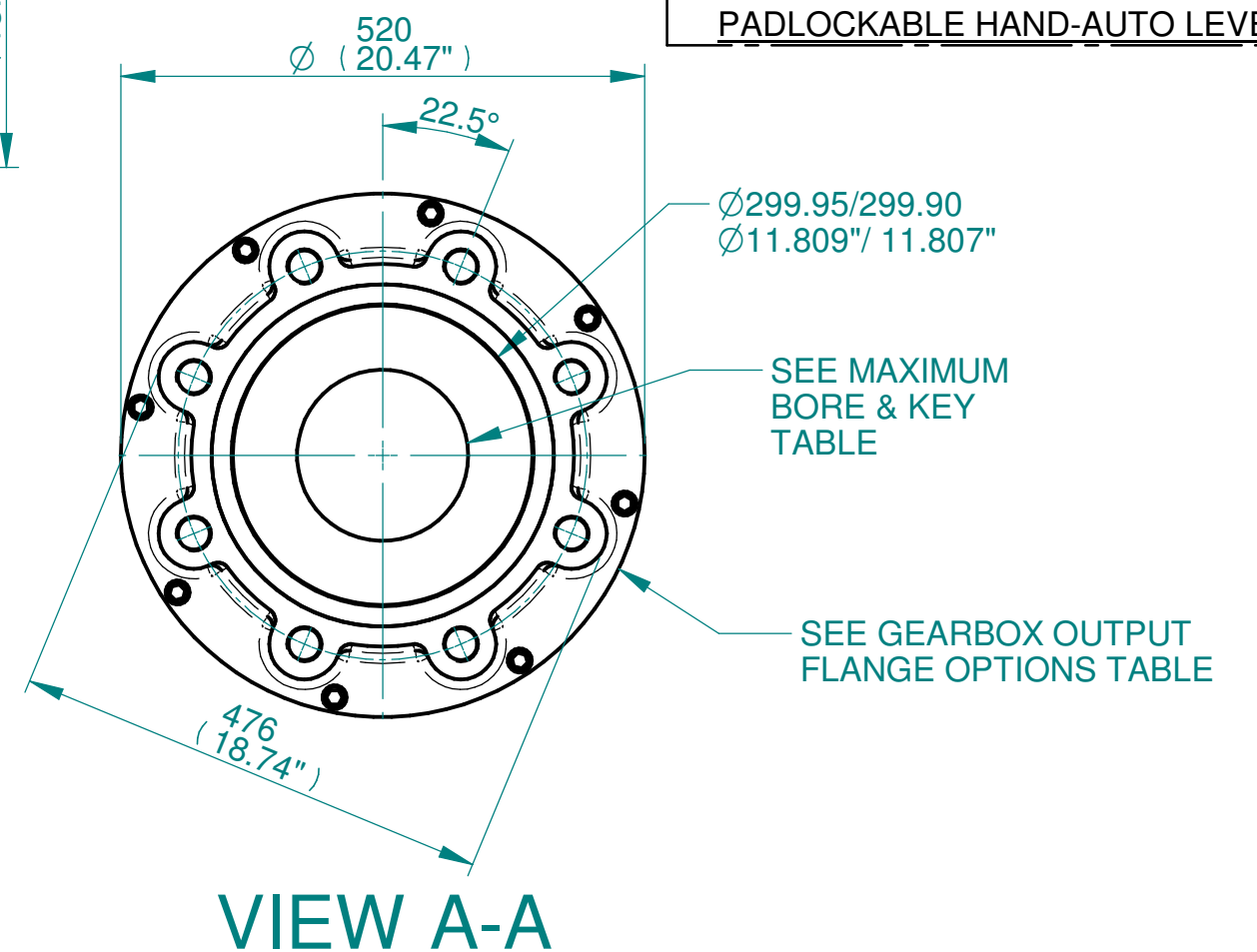
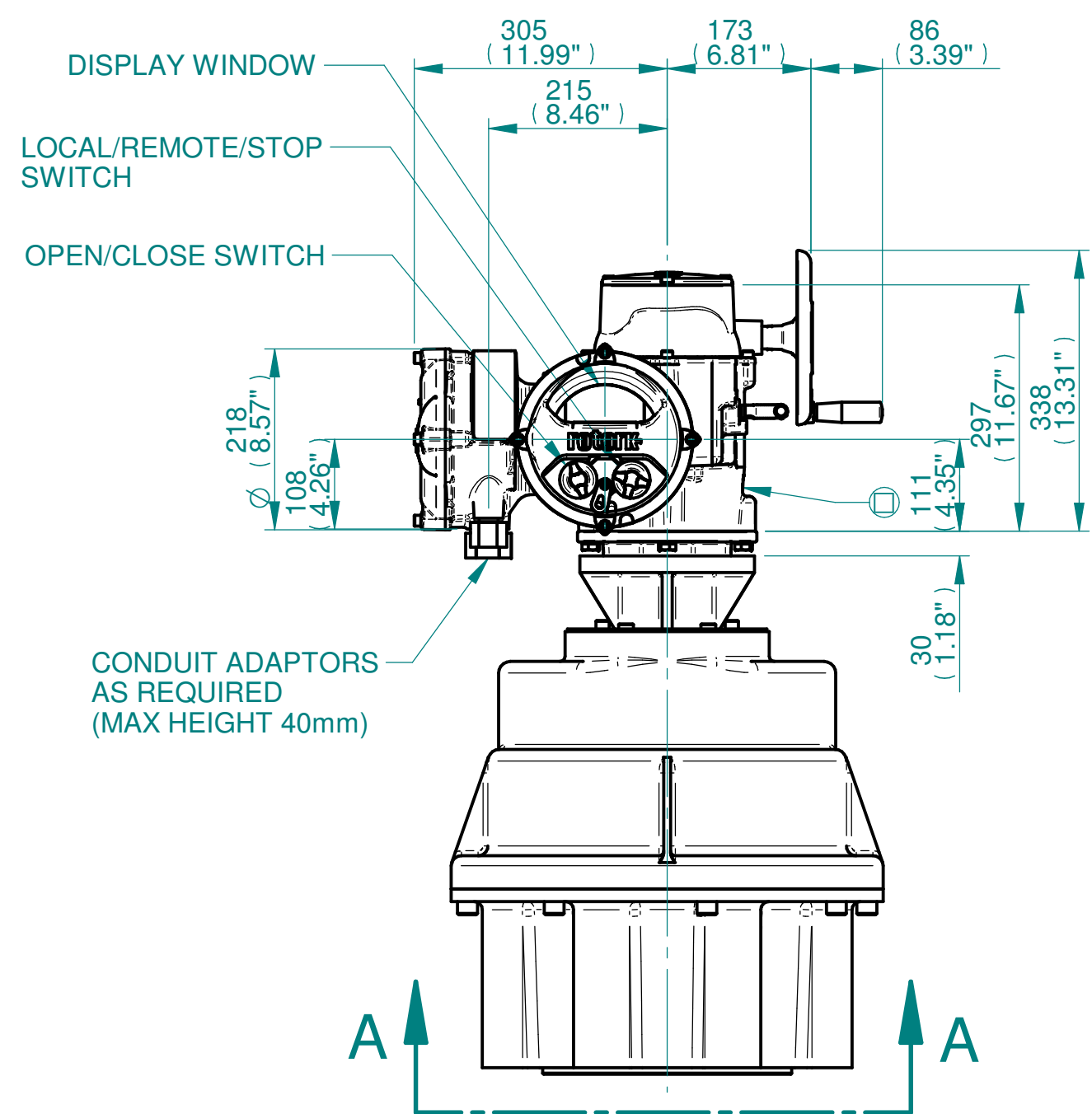
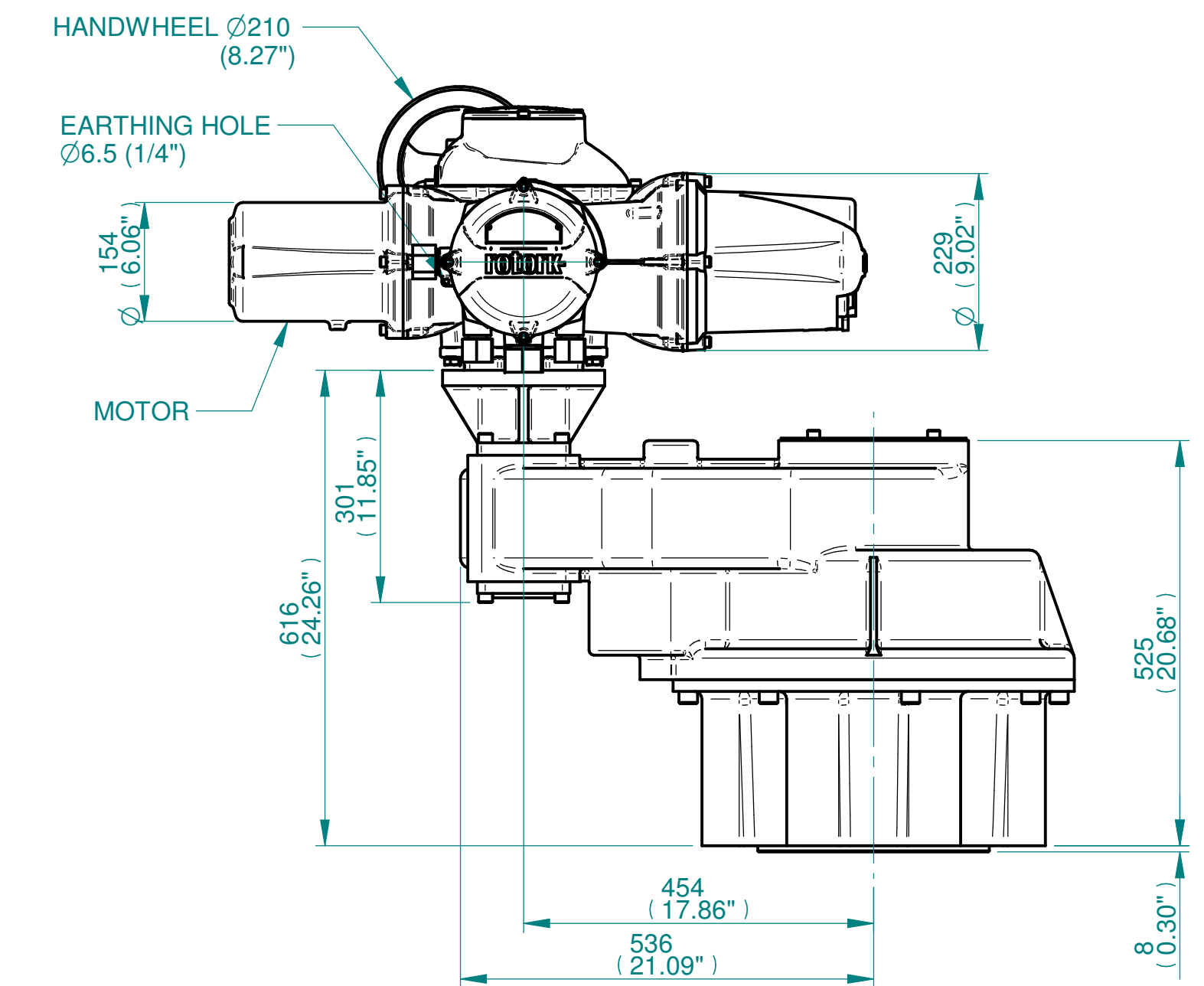

**NOTES:**  
: DIMENSIONS WITH "\*" INDICATE COVER REMOVAL ALLOWANCE  
: ELECTRONICS COVER OPTION "\*" WILL VARY DEPENDING ON CONFIGURATION  
: NETT WEIGHT = 470kg/1036lbs  
: = OIL FILLER/DRAIN PLUG  
: THE INTERFACE PROVIDED FOR MOUNTING THE ACTUATOR OR SECOND STAGE GEARBOX ONTO THE VALVE SHOULD CONFORM TO GOOD ENGINEERING PRACTICES, ENSURING ADEQUATELY TOLERANCED LIMITS FOR PARALLELISM, PERPENDICULARITY AND CONCENTRICITY.  
: ROTORK CANNOT BE HELD LIABLE FOR DAMAGE TO OUR EQUIPMENT CAUSED BY EXCESSIVE LOADING FROM COVER TUBES. (SEE ALSO PUB000-124)

**CONDUIT ENTRIES**

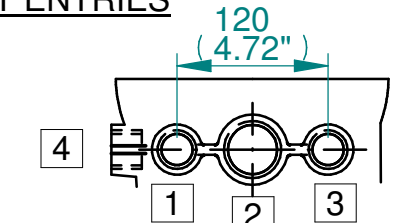

	Hole 1	Hole 2	Hole 3	Hole 4
Size	As Required	As Required	As Required	As Required
Plugged	As Required	As Required	As Required	As Required
Gland	As Required	As Required	As Required	As Required

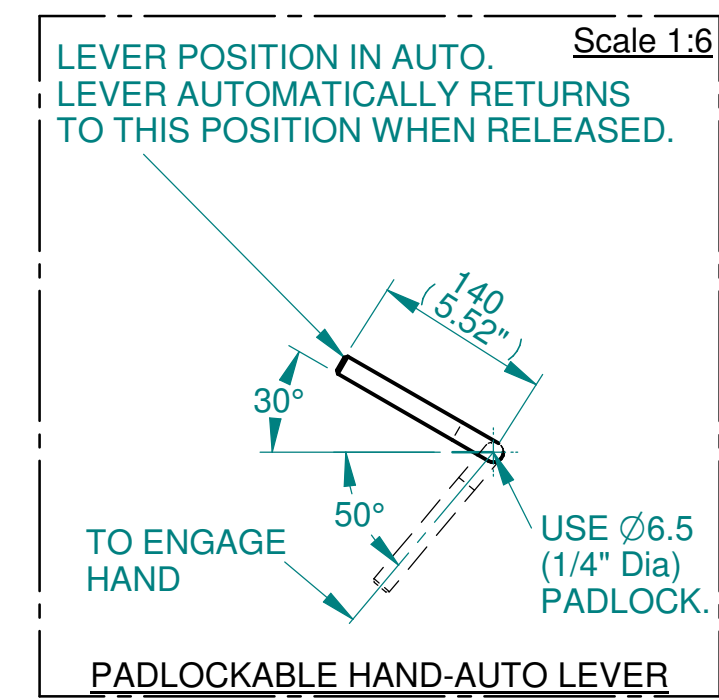

Actuator Size: IQ35, IS16		Gearbox output flange options								Maximum Bore & Key			
Title	IQ35, SIDE HANDWHEEL, IS16, F40, FA40, Ratios 10:1, 12:1 & 15:1 Installation Details	Designation	F40	-	-	-	FA40	-	-	-	Key form	Ø Bore	Key size
Drawn	DH	No. Holes	8	-	-	-	8	-	-	-	Rectangle (BS4235)	130	32 x 18
Checked	JBA	Hole size	M36	-	-	-	11/4" UNC	-	-	-	-	-	-
Date	MARCH 19	PCD	406	-	-	-	16"	-	-	-	-	-	-
Ref	SALES	Project Ref	QUOTATION	-	-	-	-	-	-	-	-	-	-

3D Models are available in various formats under the same drawing number

Issue	Description
1	FIRST ISSUE
Scale: 1:7.5	
THIRD ANGLE PROJECTION	
A2	Drawing Number Issue No Sheet No
I13SHWIS16STD	1 1 of 1

1 2 3 4 5 6 7 8 9 10 11 12