

H
G
F
E
D
C
B
A

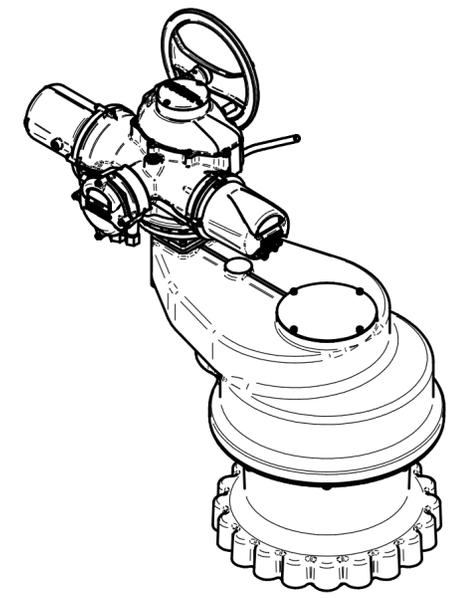

ISOMETRIC VIEW
1:15

NOTES:
 :DIMENSIONS WITH "*" INDICATE COVER REMOVAL ALLOWANCE
 :NETT WEIGHT = 1265kg/2788lbs
 : = OIL FILLER/DRAIN PLUG
 :THE INTERFACE PROVIDED FOR MOUNTING THE ACTUATOR OR SECOND STAGE GEARBOX ONTO THE VALVE SHOULD CONFORM TO GOOD ENGINEERING PRACTICES, ENSURING ADEQUATELY TOLERANCED LIMITS FOR PARALLELISM, PERPENDICULARITY AND CONCENTRICITY.
 :ROTORK CANNOT BE HELD LIABLE FOR DAMAGE TO OUR EQUIPMENT CAUSED BY EXCESSIVE LOADING FROM COVER TUBES. (SEE ALSO PUB000-124)

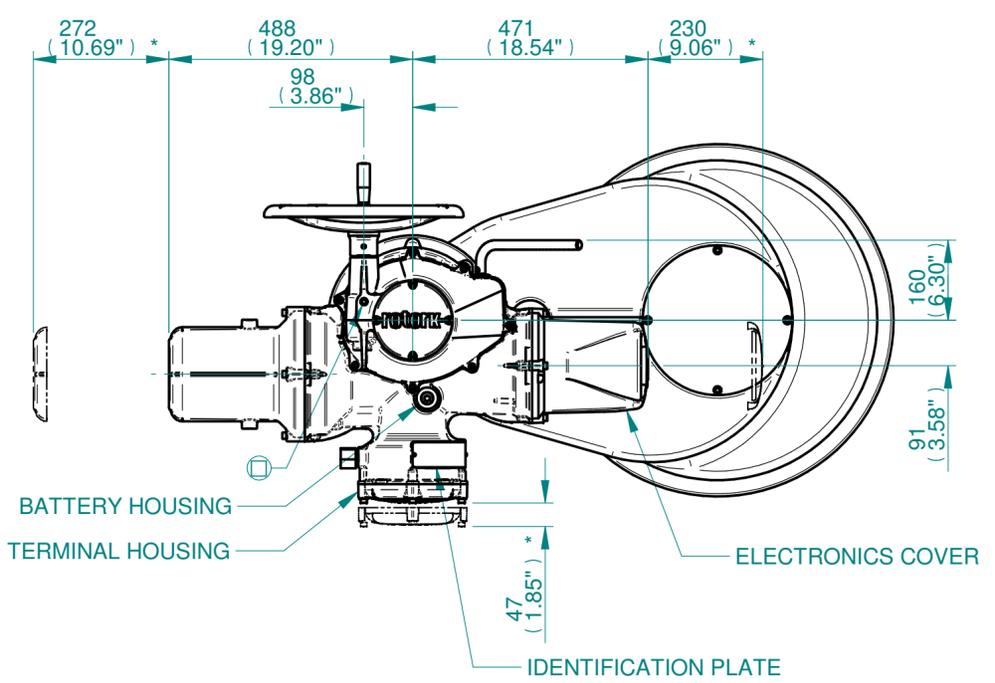
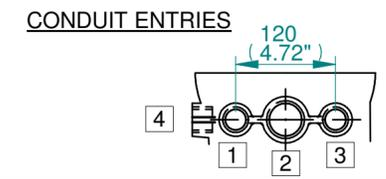

	Hole 1	Hole 2	Hole 3	Hole 4
Size	As Required	As Required	As Required	As Required
Plugged	As Required	As Required	As Required	As Required
Gland	As Required	As Required	As Required	As Required

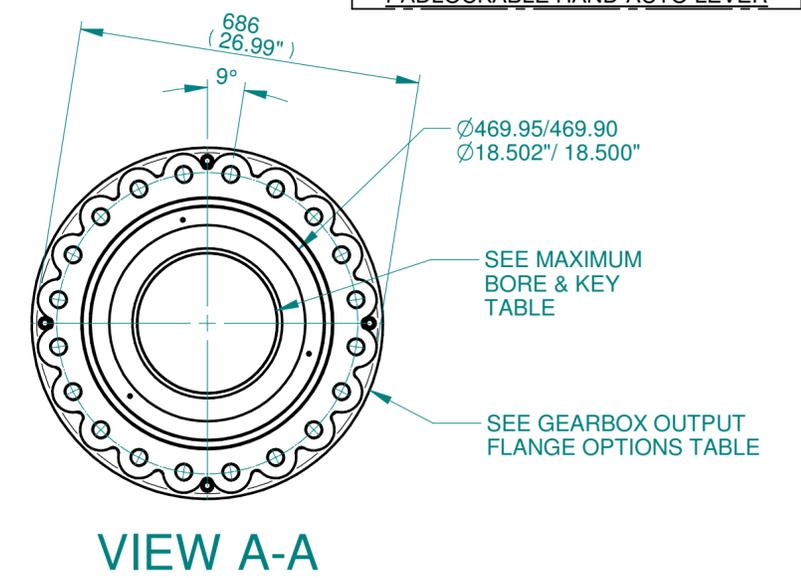
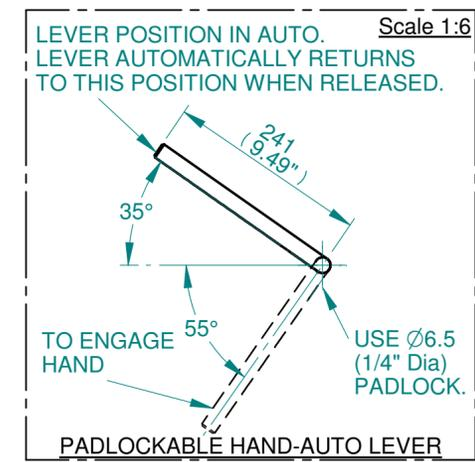
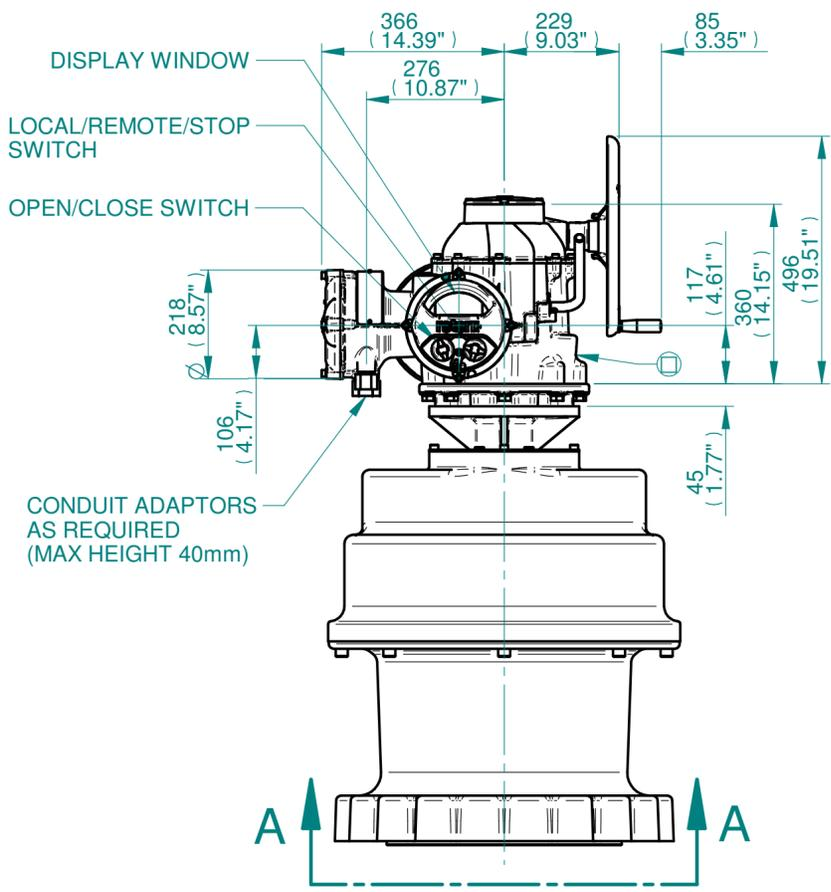
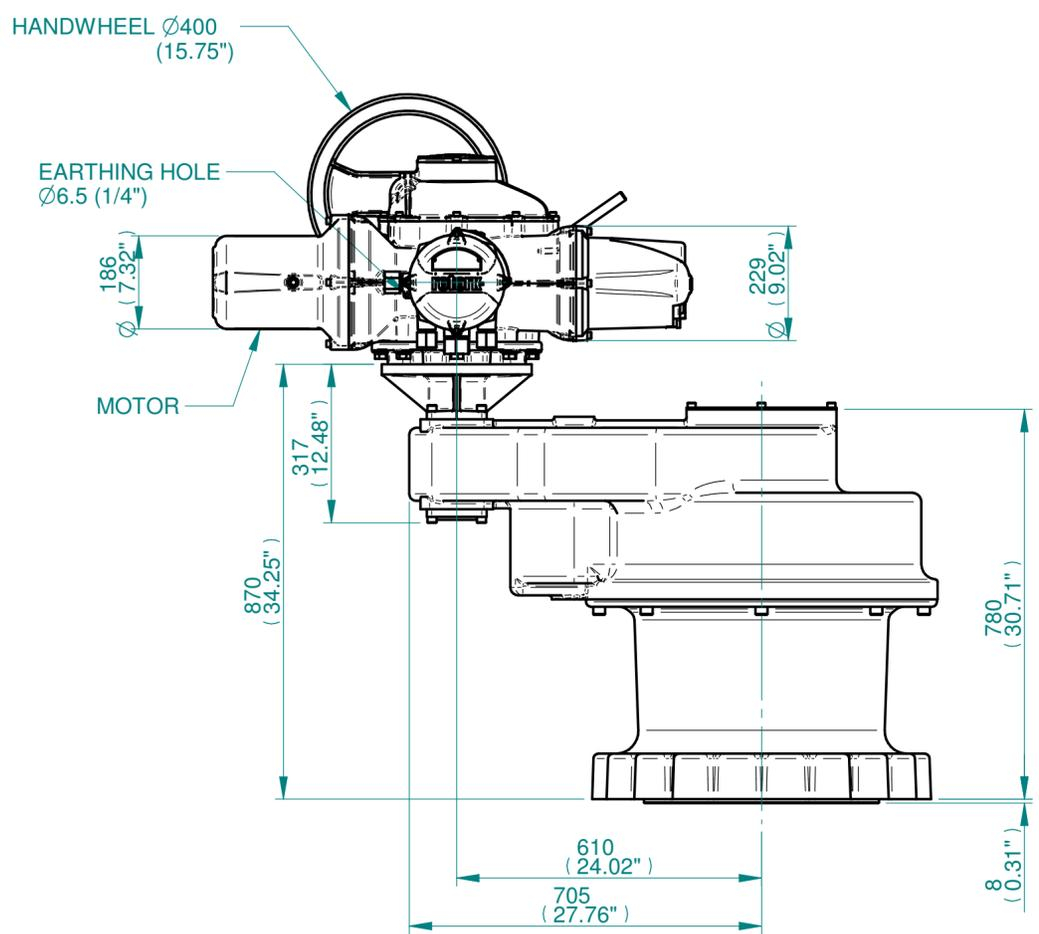

3D Models are available in various formats under the same drawing number



Rotork Controls Limited
 Bath, BA1 3JQ, England.
 Telephone 01225-733200

Actuator Size: IQ40, IS21		Gearbox output flange options								Maximum Bore & Key			
Title	IQ40, SIDE HANDWHEEL, IS21, F60, FA60, Ratios 6:1,8:1,10:1,12:1,15:1,24:1 Installation Details	Designation	F60	-	-	-	FA60	-	-	-	Key form	Ø Bore	Key size
Drawn	DH	No. Holes	20	-	-	-	20	-	-	-	Rectangle (BS4235)	206	50 x 28
Checked	JBA	Hole size	M36	-	-	-	11/4" UNC	-	-	-	-	-	-
Date	MARCH 19	PCD	603	-	-	-	23.75"	-	-	-	-	-	-
Ref	SALES	Project Ref QUOTATION											

Issue	Description
1	FIRST ISSUE

Scale: 1:10

THIRD ANGLE PROJECTION

Drawing Number	Issue No	Sheet No
I14SHWIS21STD	1	1 of 1

1 2 3 4 5 6 7 8 9 10 11 12