

**NOTES:**  
 :DIMENSIONS WITH "\*" INDICATE COVER REMOVAL ALLOWANCE  
 :NETT WEIGHT = 242kg/533lbs  
 :  = OIL FILLER/DRAIN PLUG  
 :THE INTERFACE PROVIDED FOR MOUNTING THE ACTUATOR OR SECOND STAGE GEARBOX ONTO THE VALVE SHOULD CONFORM TO GOOD ENGINEERING PRACTICES, ENSURING ADEQUATELY TOLERANCED LIMITS FOR PARALLELISM, PERPENDICULARITY AND CONCENTRICITY.  
 :ROTORK CANNOT BE HELD LIABLE FOR DAMAGE TO OUR EQUIPMENT CAUSED BY EXCESSIVE LOADING FROM COVER TUBES. (SEE ALSO PUB000-124)

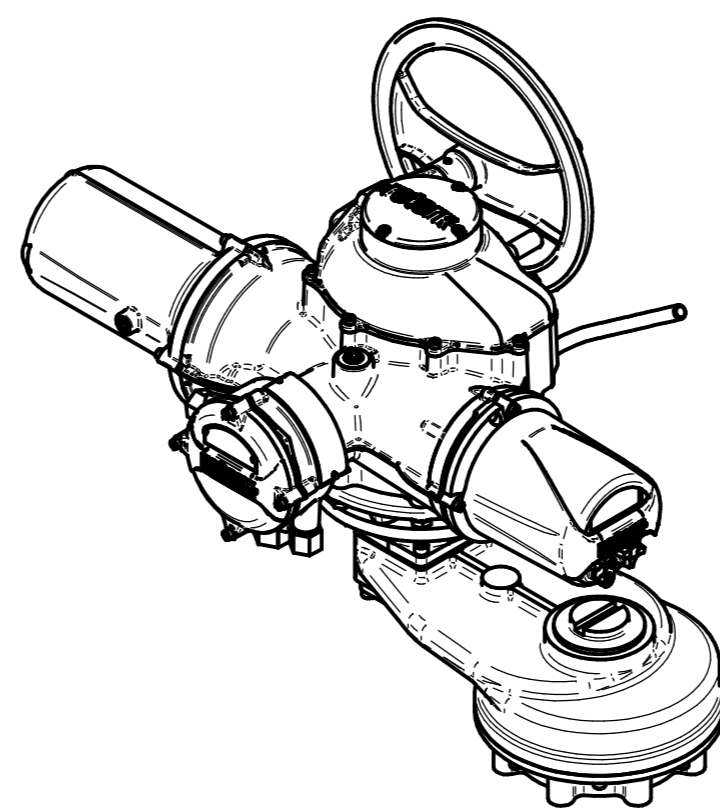

**ISOMETRIC VIEW**  
1:10

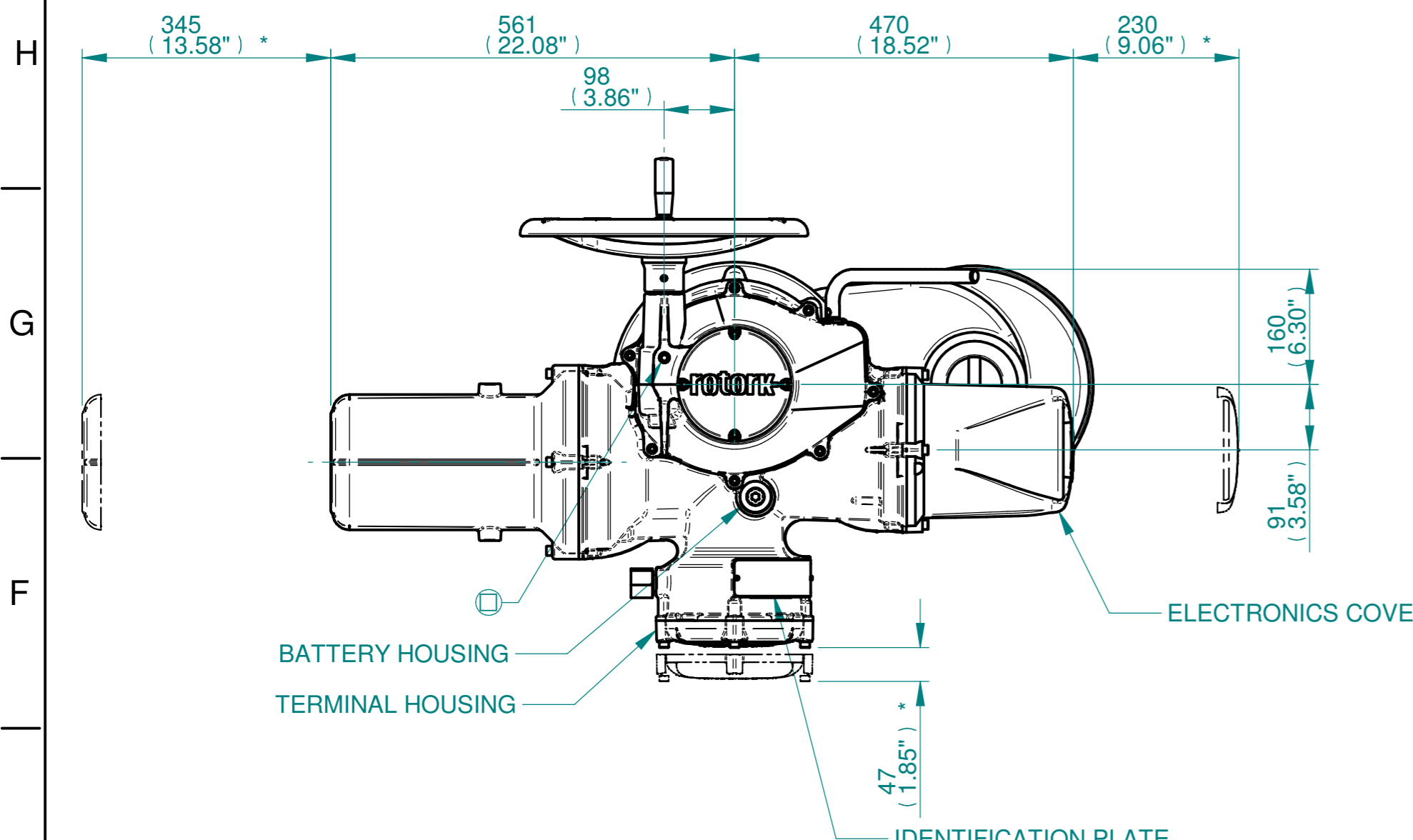
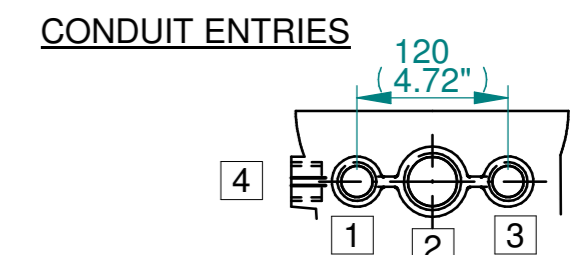

	Hole 1	Hole 2	Hole 3	Hole 4
Size	As Required	As Required	As Required	As Required
Plugged	As Required	As Required	As Required	As Required
Gland	As Required	As Required	As Required	As Required

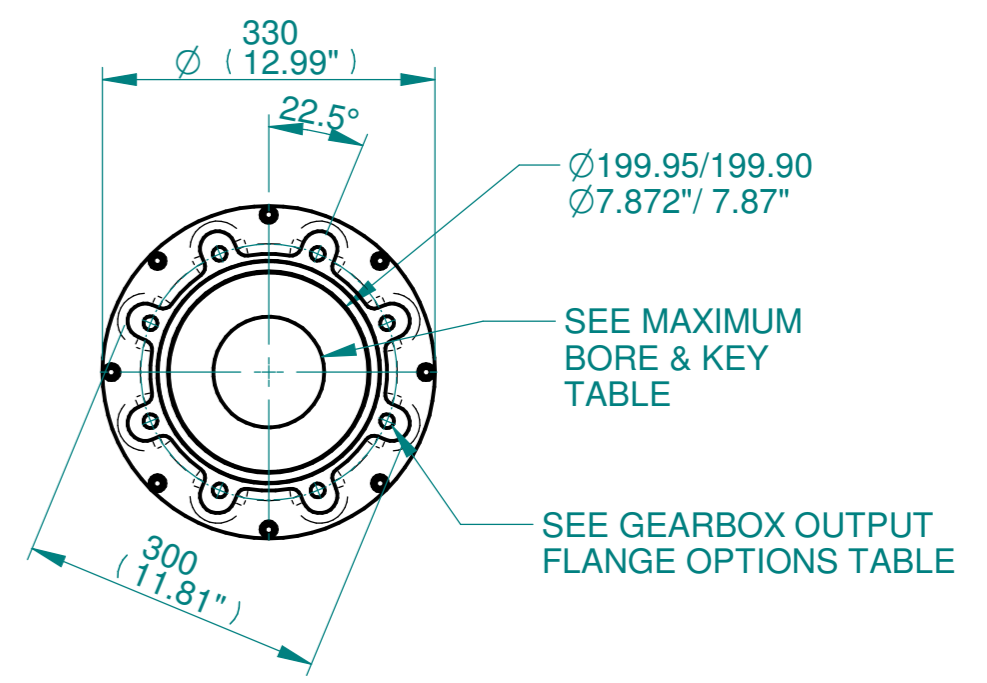
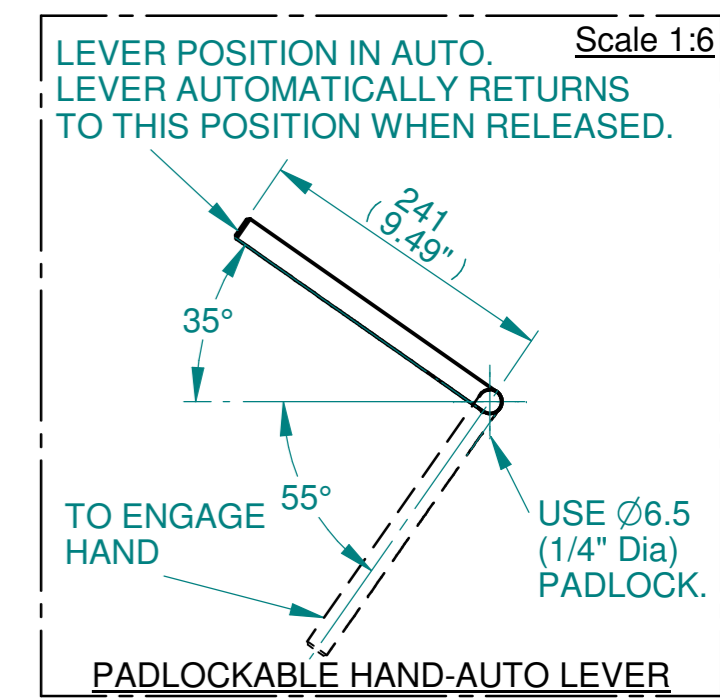
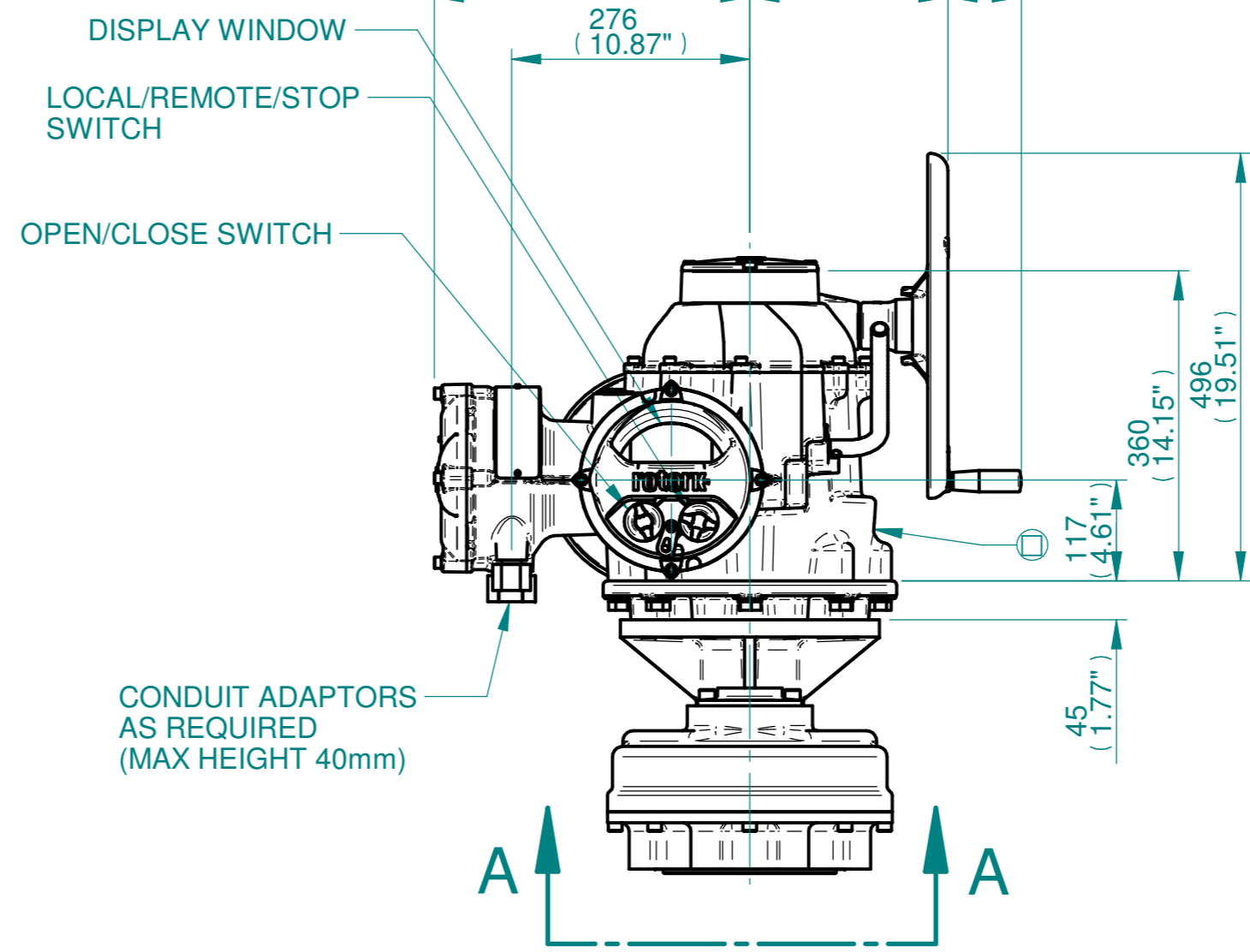
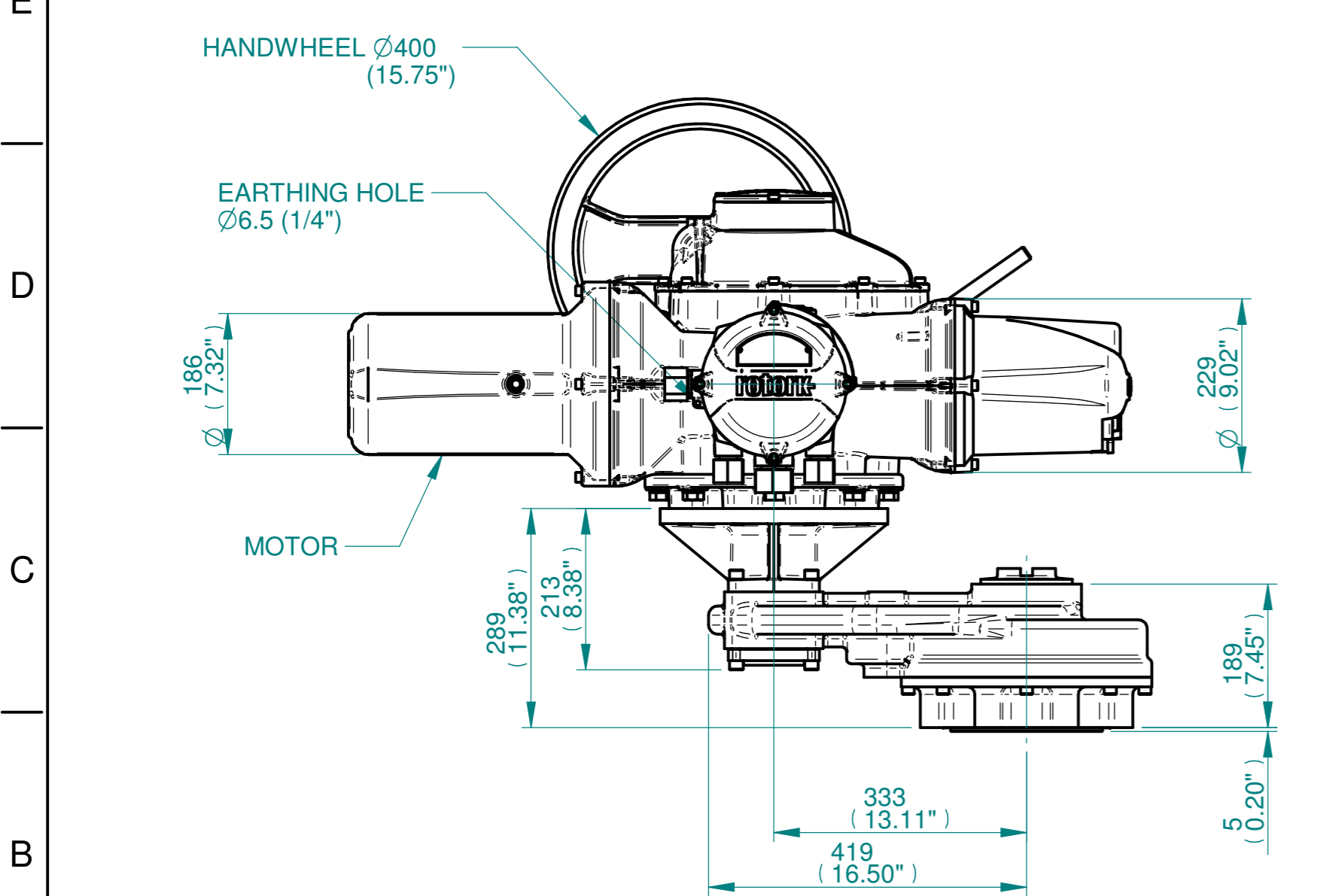

**VIEW A-A**

3D Models are available in various formats under the same drawing number



Actuator Size: IQ70,90,91,95 IS9		Gearbox output flange options								Maximum Bore & Key				
Title	IQ70,90,91,95 SIDE HANDWHEEL, IS9, F25, FA25, Ratios 4:1,6:1,8:1,10:1,12:1 15:1 Installation Details	Designation	F25	-	-	-	-	FA25	-	-	-	Key form	Ø Bore	Key size
Drawn	DH	No. Holes	8	-	-	-	-	8	-	-	-	Rectangle (BS4235)	76	22 x 14
Checked	JBA	Hole size	M16	-	-	-	-	5/8" UNC	-	-	-	-	-	-
Date	FEB 19	PCD	254	-	-	-	-	10"	-	-	-	-	-	-
Ref	SALES	Project Ref	QUOTATION	-	-	-	-	-	-	-	-	-	-	-

Issue	Description
1	FIRST ISSUE

Scale: 1:7.5  THIRD ANGLE PROJECTION

Drawing Number	Issue No	Sheet No
I15SHWIS9STD	1	1 of 1