

NOTES:
 :DIMENSIONS WITH "*" INDICATE COVER REMOVAL ALLOWANCE
 :NETT WEIGHT = 345kg/760lbs
 : = OIL FILLER/DRAIN PLUG
 :THE INTERFACE PROVIDED FOR MOUNTING THE ACTUATOR OR SECOND STAGE GEARBOX ONTO THE VALVE SHOULD CONFORM TO GOOD ENGINEERING PRACTICES, ENSURING ADEQUATELY TOLERANCED LIMITS FOR PARALLELISM, PERPENDICULARITY AND CONCENTRICITY.
 :ROTORK CANNOT BE HELD LIABLE FOR DAMAGE TO OUR EQUIPMENT CAUSED BY EXCESSIVE LOADING FROM COVER TUBES. (SEE ALSO PUB000-124)

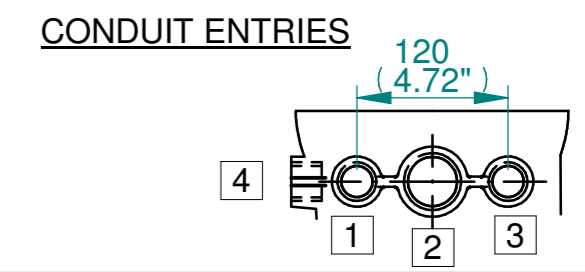

	Hole 1	Hole 2	Hole 3	Hole 4
Size	As Required	As Required	As Required	As Required
Plugged	As Required	As Required	As Required	As Required
Gland	As Required	As Required	As Required	As Required

ISOMETRIC VIEW 1:10

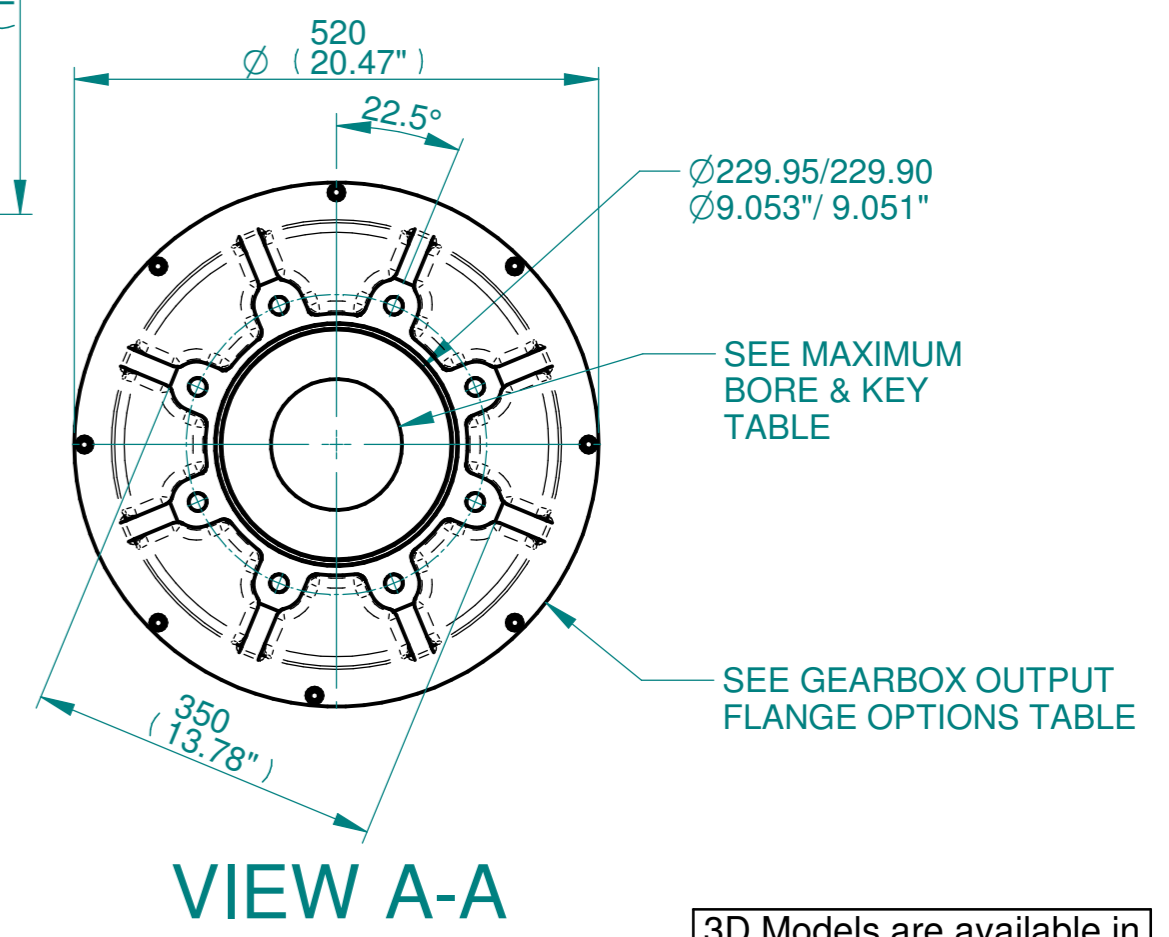
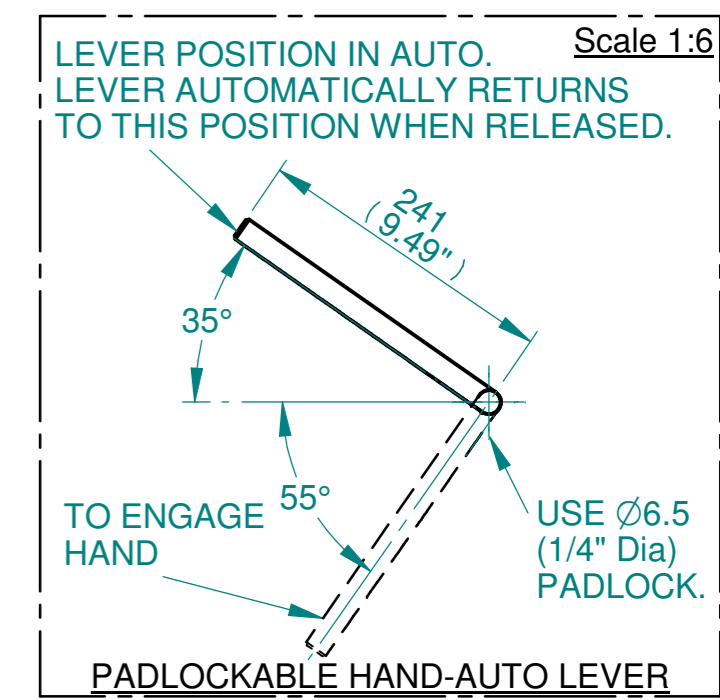
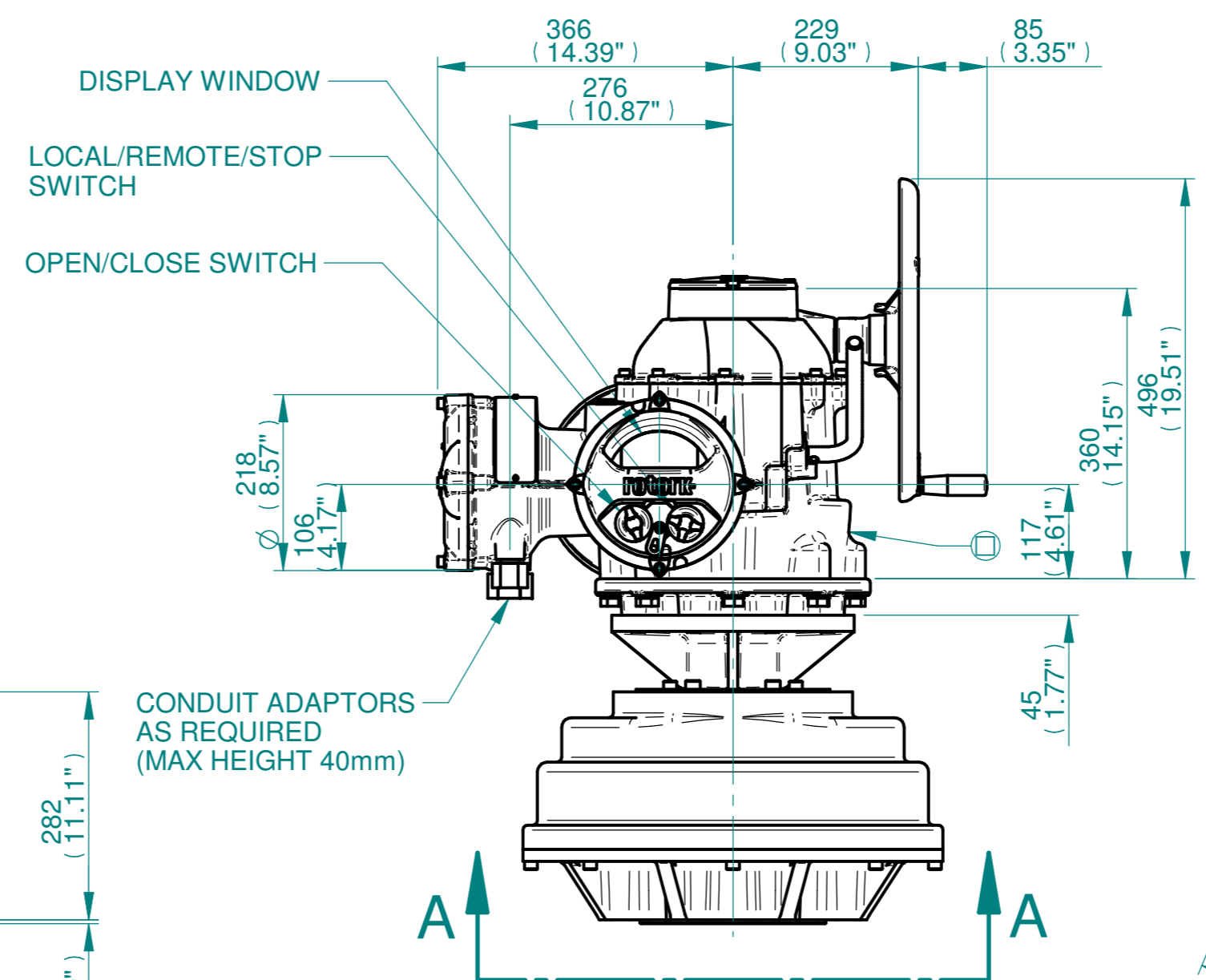
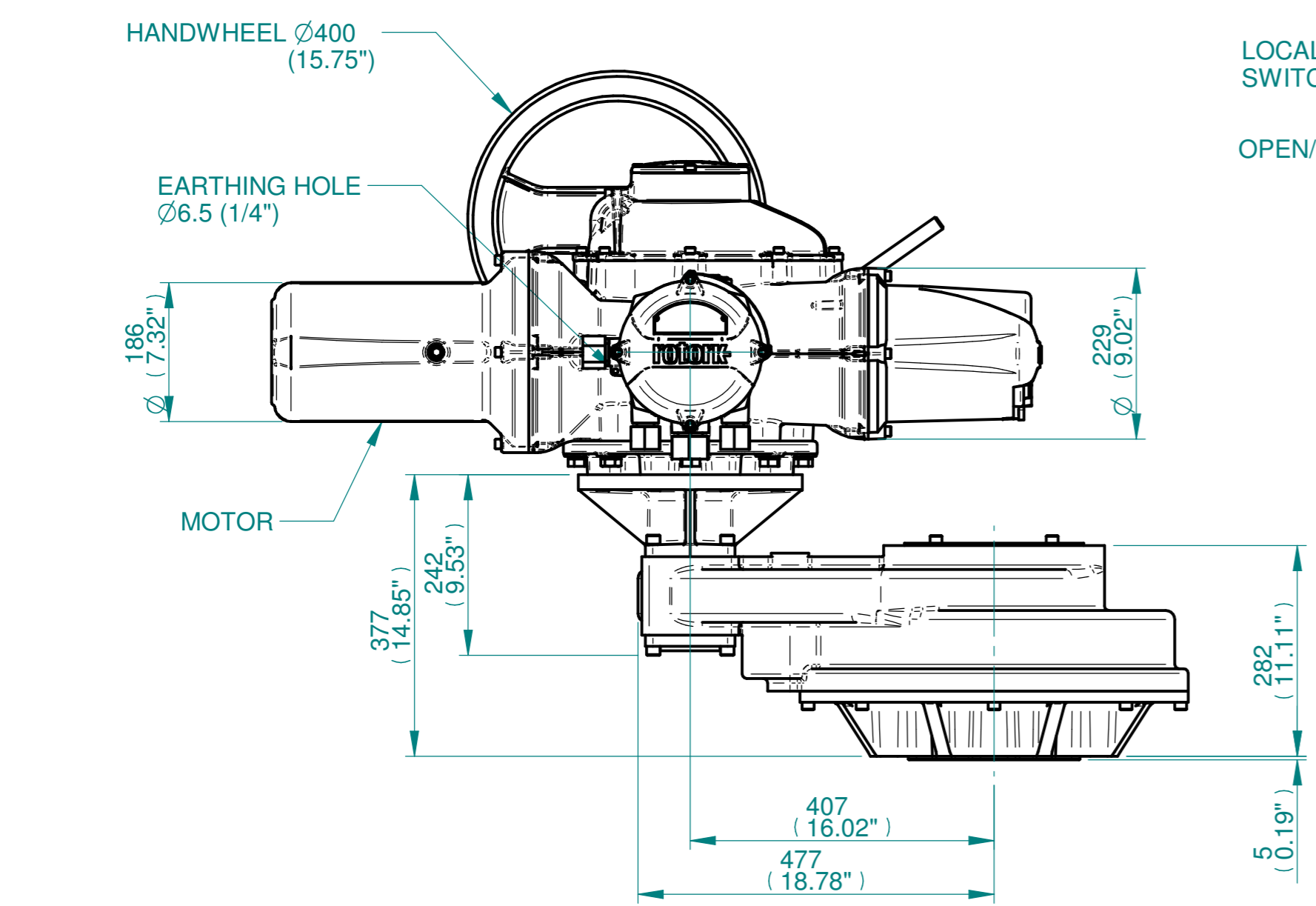

rotork
www.rotork.com
Rotork Controls Limited
Bath, BA1 3JQ, England.
Telephone 01225-733200

Actuator Size: IQ70,90,91,95 IS12		Gearbox output flange options								Maximum Bore & Key			
Title	IQ70,90,91,95 SIDE HANDWHEEL, IS12, F30, FA30, Ratios 8:1,10:1,12:1 & 15:1 Installation Details	Designation	F30	-	-	-	FA30	-	-	-	Key form	Ø Bore	Key size
Drawn	DH	Checked	JBA	Date	FEB 19	No. Holes	8	-	-	-	Rectangle (BS4235)	96	28 x 16
Hole size	M20	Hole size	3/4" UNC	PCD	298	11.73"	-	-	-	-	-	-	-
Ref	SALES	Project Ref	QUOTATION										

3D Models are available in various formats under the same drawing number

Issue	Description
1	FIRST ISSUE
Scale: 1:7.5	
THIRD ANGLE PROJECTION	
A2	Drawing Number Issue No Sheet No
I15SHWIS12STD	1 1 of 1