

KOB00220S

**PLUG-AND-SOCKET CONNECTOR LAYOUT**  
DISTRIBUCION CONECTOR PLUG AND SOCKET

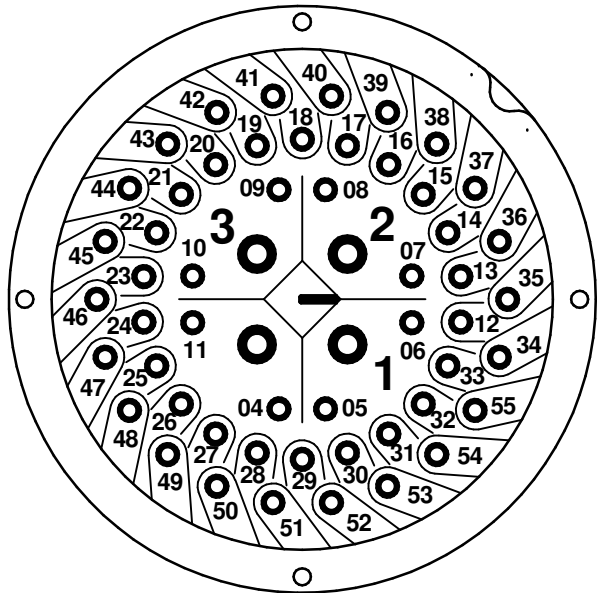

**LEGENDS: LEYENDAS:**

- M1** MOTOR ELECTRICO  
ELECTRIC MOTOR
- R1** SALIDA DE RELES N1 (ESTABLE)  
RELAY OUTPUT No1 (SETTABLE)
- R2** SALIDA DE RELES N2 (ESTABLE)  
RELAY OUTPUT No2 (SETTABLE)
- R3** SALIDA DE RELES N3 (ESTABLE)  
RELAY OUTPUT No3 (SETTABLE)
- R4** SALIDA DE RELES N4 (ESTABLE)  
RELAY OUTPUT No4 (SETTABLE)
- R5** SALIDA DE RELES N5 (ESTABLE)  
RELAY OUTPUT No5 (SETTABLE)
- R6** SALIDA DE RELES N6 (ESTABLE)  
RELAY OUTPUT No6 (SETTABLE)
- R7** SALIDA DE RELES N7 (ESTABLE)  
RELAY OUTPUT No7 (SETTABLE)
- R8** SALIDA DE RELES N8 (ESTABLE)  
RELAY OUTPUT No8 (SETTABLE)
- R9** SALIDA DE RELES N9 (ESTABLE)  
RELAY OUTPUT No9 (SETTABLE)
- R10** SALIDA DE RELES N10 (ESTABLE)  
RELAY OUTPUT No10 (SETTABLE)
- R11** SALIDA DE RELES N11 (ESTABLE)  
RELAY OUTPUT No11 (SETTABLE)
- R12** SALIDA DE RELES N12 (ESTABLE)  
RELAY OUTPUT No12 (SETTABLE)
- CS** SUMINISTRO DEL CLIENTE  
CUSTOMER SUPPLY
- BS** SOPORTE SUMINISTRO  
BACKUP SUPPLY

**POSITIONER** POSICIONADOR ENTRADA/SALIDA. SEÑAL ANALOGICA.  
POSITIONER IN/OUT ANALOG SIGNAL

**POSITIONER.LP** POSICIONADOR ENTRADA/SALIDA SEÑAL LAZO POTENCIA  
POSITIONER IN/OUT ANALOG SIGNAL LOOP POWER

**MONIT.** RELE DE MONITOR  
MONITOR RELAY

**FIELDBUS** TARJETA FIELDBUS  
FIELDBUS CARD

**REMOTE** TARJETA DE ENTRADAS REMOTAS  
REMOTE INPUT CARDS

- ACTS** SWITCH PAR CERRADO AUXILIAR  
AUXILIARY CLOSE TORQUE SWITCH
- AOTS** SWITCH PAR ABIERTO AUXILIAR  
AUXILIARY OPEN TORQUE SWITCH
- ACLS** SWITCH LIMITE CERRADO AUXILIAR  
AUXILIARY CLOSE LIMIT SWITCH
- AOLS** SWITCH LIMITE ABIERTO AUXILIAR  
AUXILIARY OPEN LIMIT SWITCH
- IP1** SWITCH POSICION INTERMEDIA POSICION (No 1)  
VALVE MIDDLE TRAVEL POSITION SWITCH (No 1)
- IP2** SWITCH POSICION INTERMEDIA POSICION (No 2)  
VALVE MIDDLE TRAVEL POSITION SWITCH (No 2)
- IP3** SWITCH POSICION INTERMEDIA POSICION (No 3)  
VALVE MIDDLE TRAVEL POSITION SWITCH (No 3)
- IP4** SWITCH POSICION INTERMEDIA POSICION (No 4)  
VALVE MIDDLE TRAVEL POSITION SWITCH (No 4)
- CPT** TRANSMISOR DE POSICION  
CURRENT POSITION TRANSMITTER
- CTI** TRANSMISOR DE PAR  
CURRENT TORQUE TRANSMITTER
- CPT.LP** TRANSMISOR DE POSICION, ALIMENTACION LAZO  
CURRENT POSITION TRANSMITTER, LOOP POWER
- CTT.LP** TRANSMISOR DE PAR, ALIMENTACION LAZO  
CURRENT TORQUE TRANSMITTER, LOOP POWER

- CTS** SWITCH PAR CERRADO  
CLOSE TORQUE SWITCH
- OTS** SWITCH PAR ABIERTO  
OPEN TORQUE SWITCH
- CLS** SWITCH LIMITE CERRADO  
CLOSE LIMIT SWITCH
- OLS** SWITCH LIMITE ABIERTO  
OPEN LIMIT SWITCH
- TRM** DISPOSITIVO PROTECCION TERMICA (BOBINADO MOTOR)  
THERMAL PROTECTION DEVICE (MOTOR WIND)
- HT** CALENTADOR ANTI-CONDENSACION  
ANTI-CONDENSATION HEATER
- BLK** BLINKER SWITCH  
BLINKER SWITCH
- POT** POTENCIOMETRO (SEÑAL POSICION VALVULA)  
POTENTIOMETER (VALVE POSITION SIGNAL)
- CPT** TRANSMISOR DE POSICION (SEÑAL POSICION VALVULA)  
CURRENT POSITION TRANSMITTER (VALVE POSITION SIGNAL)
- DSM** RELOJERIA DIGITAL (SEÑALES DE POSICION Y PAR ELECTRONICAS).  
DIGITAL SWITCH MECHANISM (ELECTRONIC VALVE POSITION AND TORQUE SIGNALS)

**NOTAS:**

- EL "TERMINAL PLAN" MUESTRA UN ACTUADOR MULTIVUELTA EN POSICION INTERMEDIA. ACTUADOR CERRANDO VALVULA HORARIA.
- VER MANUAL USUARIO Y DATASHEETS DEL ACTUADOR PARA DATOS TECNICOS, PARAMETROS Y DESCRIPCIONES ACTUADOR ELECTRICO Y EQUIPO ELECTRONICO.
- SI EL ACTUADOR ES CONFIGURADO PARA IGNORAR EL TERMOSTATO DE PROTECCION DEL MOTOR, EL ACTUADOR DEJARA DE CUMPLIR CON LAS CONDICIONES DE SEGURIDAD BASICA.
- EL USUARIO DEBE INCLUIR RELE DE SOBRECARGA CLASE 10. EL RELE DEBERA SER DIMENSIONADO COMO DISPOSITIVO DE PROTECCION DE SOBRECORRIENTE PARA EL MOTOR.
- VER HOJA DE DATOS DEL MOTOR PARA ESTE VALOR. EL RELE DE SOBRECARGA DEBE SER DIMENSIONADO PARA GARANTIZAR QUE DISPARA ANTES DE 10 SEGUNDOS EN CONDICION DE FALLO.
- EL USUARIO DEBE REALIZAR UNA EVALUACION DE RIESGOS E IMPLEMENTAR LAS MEDIDAS NECESARIAS PARA GARANTIZAR QUE EL SISTEMA RESULTANTE CUMPLE CON LA LEGISLACION VIGENTE.

**NOTES:**

- THE TERMINAL PLAN SHOWS THE MULTI-TURN ELECTRIC ACTUATOR IN INTERMEDIATE POSITION, ACTUATOR CLOSES VALVE CLOCKWISE.
- SEE ACTUATOR USER MANUAL AND DATASHEETS FOR TECHNICAL DATA, PARAMETERS AND DESCRIPTION OF THE ACTUATOR ELECTRIC AND ELECTRONIC EQUIPMENT.
- IF THE ACTUATOR IS CONFIGURED TO BYPASS THE MOTOR PROTECTION THERMOSTAT (TRM), THE ACTUATOR WILL NO LONGER COMPLY WITH THE ESSENTIAL SAFETY REQUIREMENTS.
- THE USER MUST FIT A CLASS 10 OVERLOAD RELAY. THE RELAY MUST BE SIZED ACCORDING TO THE OVERCURRENT PROT. DEVICE SETTING VALUE FOR THE MOTOR.
- REFER TO THE MOTOR DATA SHEET FOR THIS VALUE. THE OVERLOAD RELAY MUST BE SIZED TO ENSURE THAT IT TRIPS WITHIN 10 SECONDS IN A FAULT CONDITION.
- THE USER MUST COMPLETE A RISK ASSESSMENT AND IMPLEMENT WHATEVER MEASURES ARE REQUIRED TO ENSURE THAT THE RESULTANT SYSTEM COMPLIES WITH ALL APPLICABLE LEGISLATION.

PARAMETER	VALUE	DESCRIPTION
TYPE	K	MULTI-TURN ELECTRIC ACTUATOR, WITH CENTRONIK (DIGITAL SWITCH MECH)
MAIN POWER SUPPLY	0	A.C. THREE PHASE
EXTRA CARD No 1	B	POSITIONER IN/OUT ANALOG SIGNAL
EXTRA CARD No2	0	NO (WITHOUT)
MOTOR STARTER	0	REVERSIBLE CONTACTORS (STANDARD)
CUSTOMER SUPPLY & BLUETOOTH	2	24VDC±20% AT MAX.POW.OUTPUT 5W, AND BLUETOOTH CARD FOR REMOTE SETTING TOOL
BACKUP SUPPLY & HEATER	2	NO BACKUP SUPPLY, HEATER INCLUDED
EXTRA SWITCH	0	STANDARD, WITHOUT

ISSUE	DATE	ISSUE	DATE
1	FIRST RELEASE	09-08-19	3
2			4

SHEET 1/2	DATE	SIGN.	<b>TERMINAL PLAN</b> WD CCK-CCKRE CTK, DSM, 3PH, POS, NOEX2, CTR, CS24-BT, NOBK-HT, NOEXT		FORMAT	DRAWING N°
MADE BY	09/08/2019	JB			A4	KOB00220S - 1
CHECKED	09/08/2019	JP				
APPROVED	09/08/2019	JP				

This drawing and the information it contains are property of Rotork Controls Limited, and they will not be reproduced or disclosed, in whole or in part, without the prior written consent of Rotork.

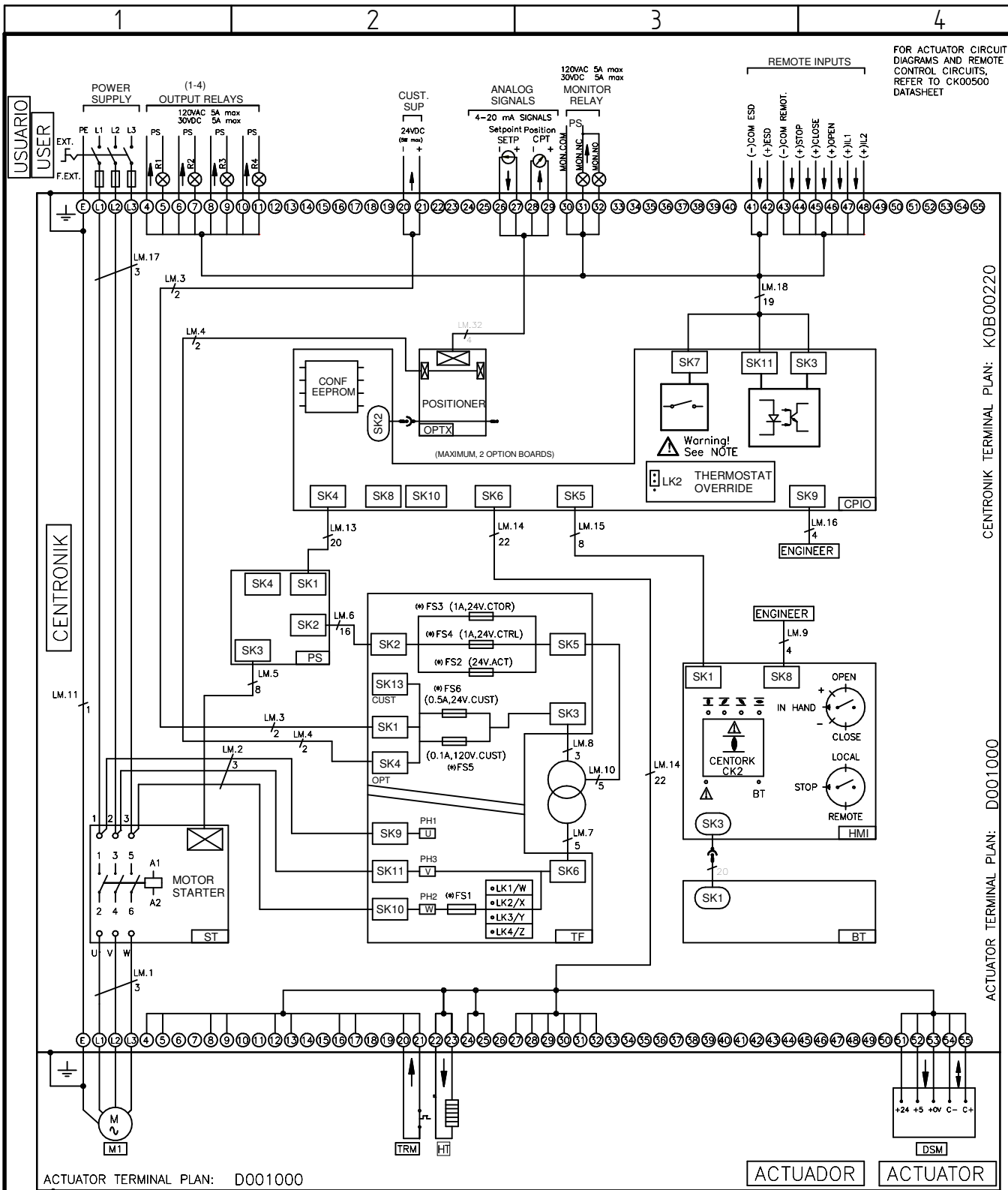

ACTUATOR TERMINAL PLAN: D001000

ACTUADOR ACTUADOR

**WARNING:** REFER TO SAFE USE AND INSTALLATION MANUAL OR CK00500 DATASHEET FOR APPROVED FUSES.  
 FS1: ACCORDING TO THE POWER SUPPLY VOLTAGE 110VAC/115VAC: FS1 (0,25 A)

TRANSFORMER TAPPING OPTIONS

TAP		PRIMARY TAP NOMINAL VOLTAGE (VAC 50/60Hz)		
LK	W	LV	EU	HV
LK1	W	110/115/120	380	460
LK2	X	220/230	400	480
LK3	Y	240	415	500
LK4	Z	n/a	440	600

EL "TERMINAL PLAN" MUESTRA UN ACTUADOR ELECTRICO EN POSICION INTERMEDIA EL ACTUADOR CIERRA ANUALMENTE EN CUALQUIER VOLTAJE HORARIOES1 (0,25 A) VER MANUAL DE USUARIO PARA DATOS TECNICOS, PARAMETROS Y DESCRIPCION DEL ACTUADOR ELECTROICO Y EQUIPOS ELECTRONICOS. ACTUADORES CON THIRISTORE (SSS), EL ACTUADOR DEBE SER PROTEGIDO UTILIZANDO FUSIBLES SEMI-CONDUCTOR ALTA VELOCIDAD DE RENDIMIENTO APROPIADOS PARA EL SUMINISTRO ENTRANTE. SI EL ACTUADOR ESTA CONFIGURADO PARA INHIBIR LA PROTECCION POR TERMOSTATO DEL MOTOR (TRM), YA NO CUMPLIRA CON LAS CONDICIONES BASICAS DE SEGURIDAD. EL USUARIO DEBE REALIZAR UNA EVALUACION DE RIESGOS, E IMPLEMENTAR LAS MEDIDAS DE SEGURIDAD QUE SE REQUIERA, PARA ASEGURAR QUE EL SISTEMA RESULTANTE CUMPLE CON LAS DIRECTIVAS DE BAJO VOLTAGE, Y CUALQUIER OTRA LEGISLACION VIGENTE EN EL SITIO DE INSTALACION. THE TERMINAL PLAN SHOWS THE MULTI-TURN ELECTRIC ACTUATOR IN INTERMEDIATE POSITION, ACTUATOR CLOSES VALVE CLOCKWISE. REFER TO SAFE USE AND INSTALLATION MANUAL AND DATASHEETS FOR TECH. DATA, PARAMETERS AND DESCRIPTION OF THE ACTUATOR ELECTRIC AND ELECTRONIC EQUIPMENT. ACTUATORS WITH SOLID STATE STARTER (SSS), THE ACTUATOR MUST BE PROTECTED USING SUITABLE RATED HIGH SPEED SEMI-CONDUCTOR FUSES ON THE INCOMING SUPPLY IF THE ACTUATOR IS CONFIGURED TO BYPASS THE MOTOR PROTECTION THERMOSTAT (TRM), THE ACTUATOR WILL NO LONGER COMPLY WITH THE ESSENTIAL SAFETY REQUIREMENTS. THE USER MUST CONDUCT A RISK ASSESSMENT, AND IMPLEMENT WHATEVER EXTRA SAFETY MEASURES ARE REQUIRED, TO ENSURE THAT THE RESULTANT SYSTEM COMPLIES WITH THE LOW VOLTAGE DIRECTIVE, AND ANY OTHER LEGISLATION IN FORCE AT THE INSTALLATION SITE.

ISSUE	DATE	ISSUE	DATE
1	FIRST RELEASE	09-08-19	3
2			4

SHEET 2/2	DATE	SIGN.	WIRING DRAWING	This drawing and the information it contains are property of Rotork Controls Limited, and they will not be reproduced or disclosed, in whole or in part, without the prior written consent of Rotork.	
MADE BY	09/08/2019	JB	WD CKC-CKRC CTK., DSM, 3PH, POS, NOEX2, CTOR, CS24-BT, NOBK-HT, NOEXT		
CHECKED	09/08/2019	JP		FORMAT	DRAWING N°
APPROVED	09/08/2019	JP		A4	KOB00220S-1

CENTRONIK TERMINAL PLAN: KOB00220  
ACTUATOR TERMINAL PLAN: D001000