

E-FLANGE INPUT

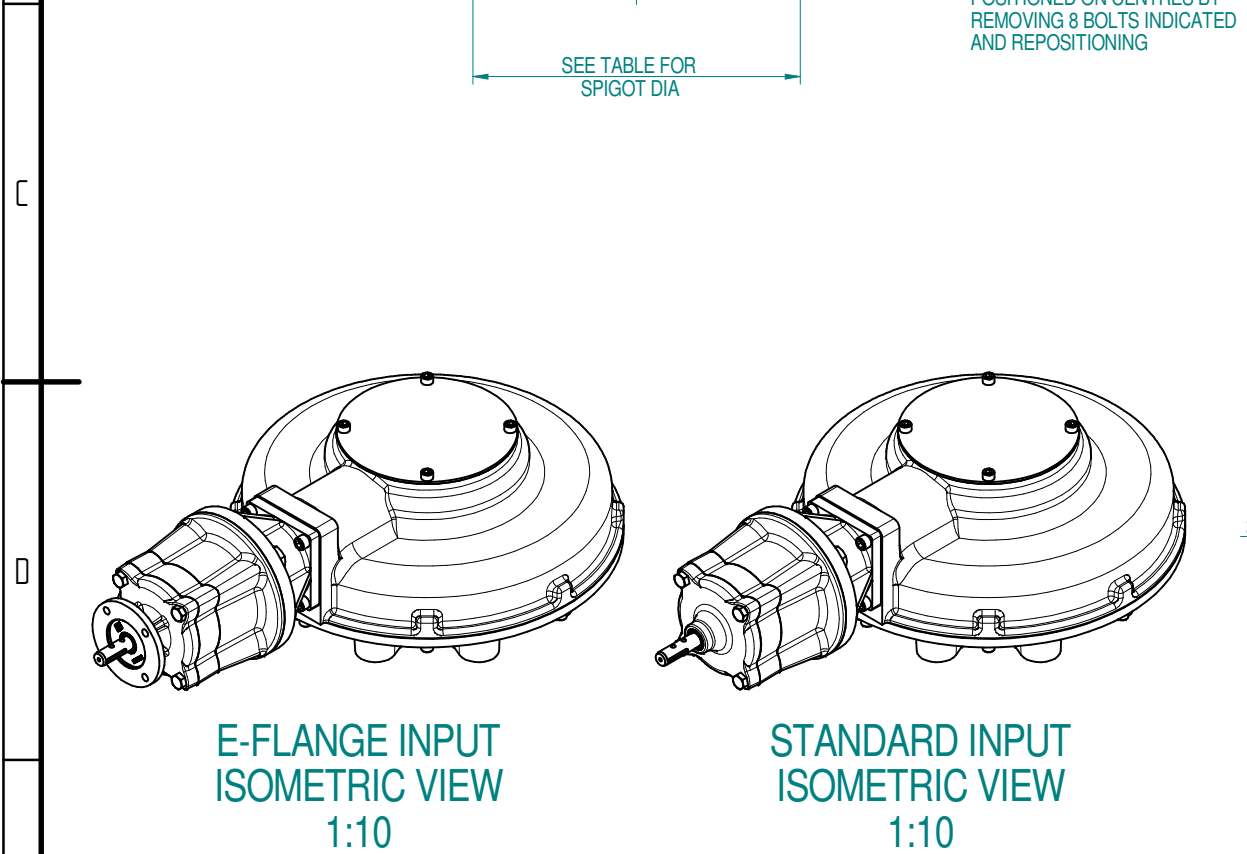

STANDARD INPUT

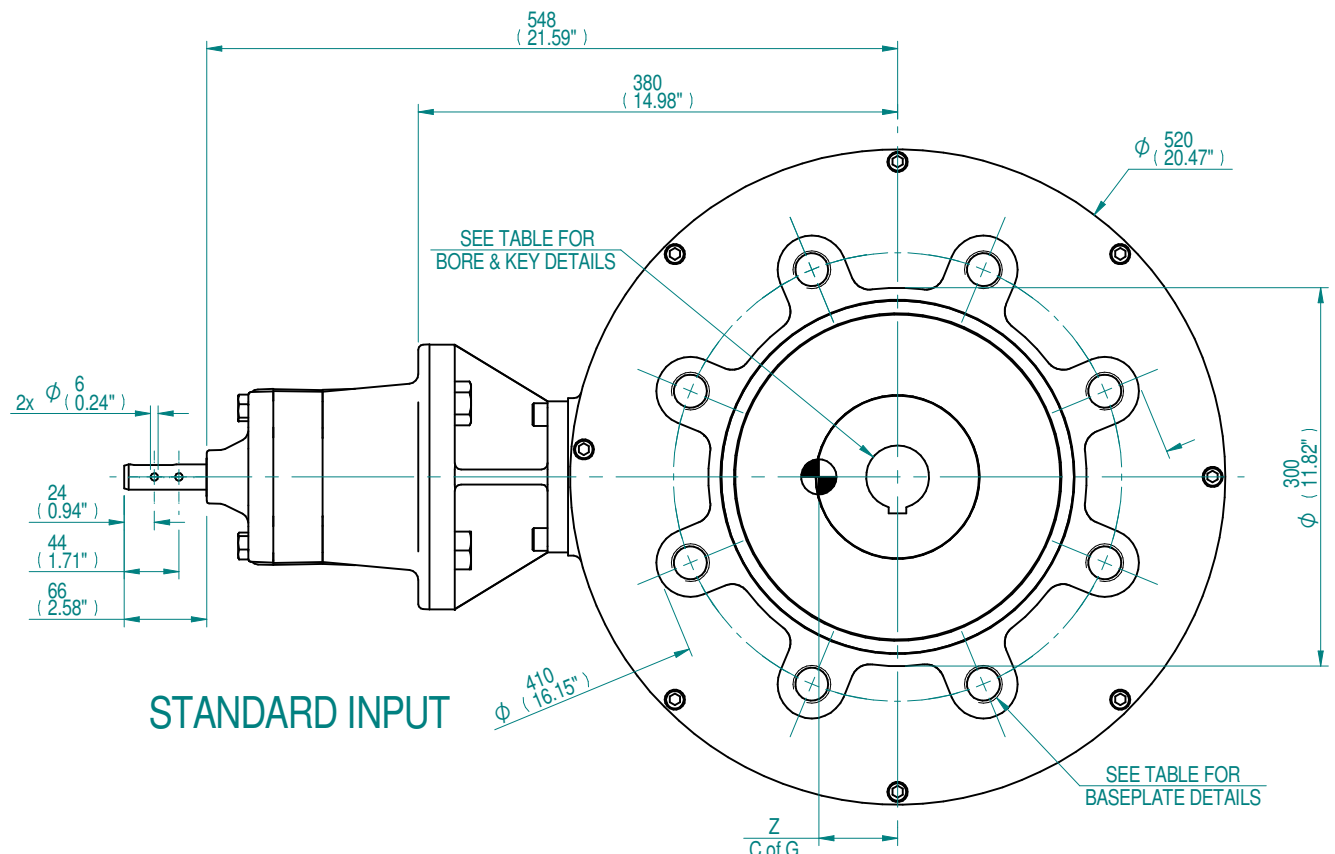

NOTE:
MPR IS NOT SUITABLE FOR MOTORISED APPLICATIONS.

COMMON INPUT DETAILS		E-FLANGE INPUT DETAILS			
SHAFT DIA.	KEY DETAILS	FLANGE O/DIA.	RECESS DIA.	RECESS DEPTH	HOLE DETAILS (45° OFF CENTRES)
Ø19.98-0.05	6x6x36	Ø125	Ø70 +0.07	5.5	4 HOLES Ø10.5 ON Ø102.0 P.C.
(Ø0.787"-0.002")	(0.24"x0.24"x1.42")	(Ø4.92")	(Ø2.756"+0.003")	(0.22")	4 HOLES Ø0.41" ON Ø4.02" P.C.

STANDARD	MOUNTING HOLES - BOLT CIRCLE (OFF CENTRES)	
	SPIGOT DIAMETER	HOLE DETAILS (22.5° OFF CENTRES)
ISO F35	Ø259.95-0.05 (Ø10.234"-0.002")	8 HOLES M30x40 (1.57") DEEP ON Ø356.0 (Ø14.02") P.C.
FA35	Ø215.80-0.25 (Ø8.496"-0.008")	8 HOLES 1"UNCx40 (1.57") DEEP ON Ø355.6 (Ø14.00") P.C.

MAX BORE SQ KEY			MAX BORE RECTANGULAR KEY		MAX. STEM SCREW ACCEPTANCE DIA.
STD	BORE	KEY	BORE	KEY	
BS4235	-	-	96.0	28X16	100 (3.875")
BS46	3.500"	7/8" SQ	3.625"	1" x 3/4"	
ANSI B17.1	3.500"	7/8" SQ	3.625"	7/8" x 5/8"	

DESCRIPTION			TORQUE		C of G		
MPR	RATIO	MA +/- 15%	OUTPUT	INPUT	X	Y	Z
MPR19	153.6	104.7	10846 Nm	103 Nm	0	65	63

AS PART OF CONTINUOUS PRODUCT DEVELOPMENT, ALL DETAILS SUBJECT TO CHANGE WITHOUT PRIOR NOTICE. FOR UP TO DATE DETAILS PLEASE VISIT www.rotork.com

	This drawing is confidential and is the property of Rotork Gears and must not be reproduced either wholly or partly. All rights in respect of patents, designs and copyrights are reserved. © 2019	Document type	PUBLICITY	Mass	182.71 kg	Title HOB12 GEARBOX MPR19 MANUAL INPUT REDUCER F35/FA35 OUTPUT
		Dimensions in mm Scale 1:6		Created	M JONES	
www.rotork.com		Checked	N COOPE	04/04/2019	Rev A	
		Approved	-	-	Sheet 1 of 1 Size A3	

Rev	CN	Revised	Approved	Date	Change Description
A	-	-	-	-	FIRST ISSUE