

CIRCUIT IS DRAWN FOR A VALVE IN THE FULLY CLOSED POSITION

CIRCUIT IS DRAWN FOR A VALVE IN THE FULLY CLOSED POSITION

Circuit Diagram No - Issue No
2S35Q00 - 04

WARNING

IT IS ESSENTIAL THAT REMOTE CONTROL CIRCUITS ARE DESIGNED SO THAT AN OPEN AND A CLOSE SIGNAL CAN NEVER BE APPLIED SIMULTANEOUSLY.

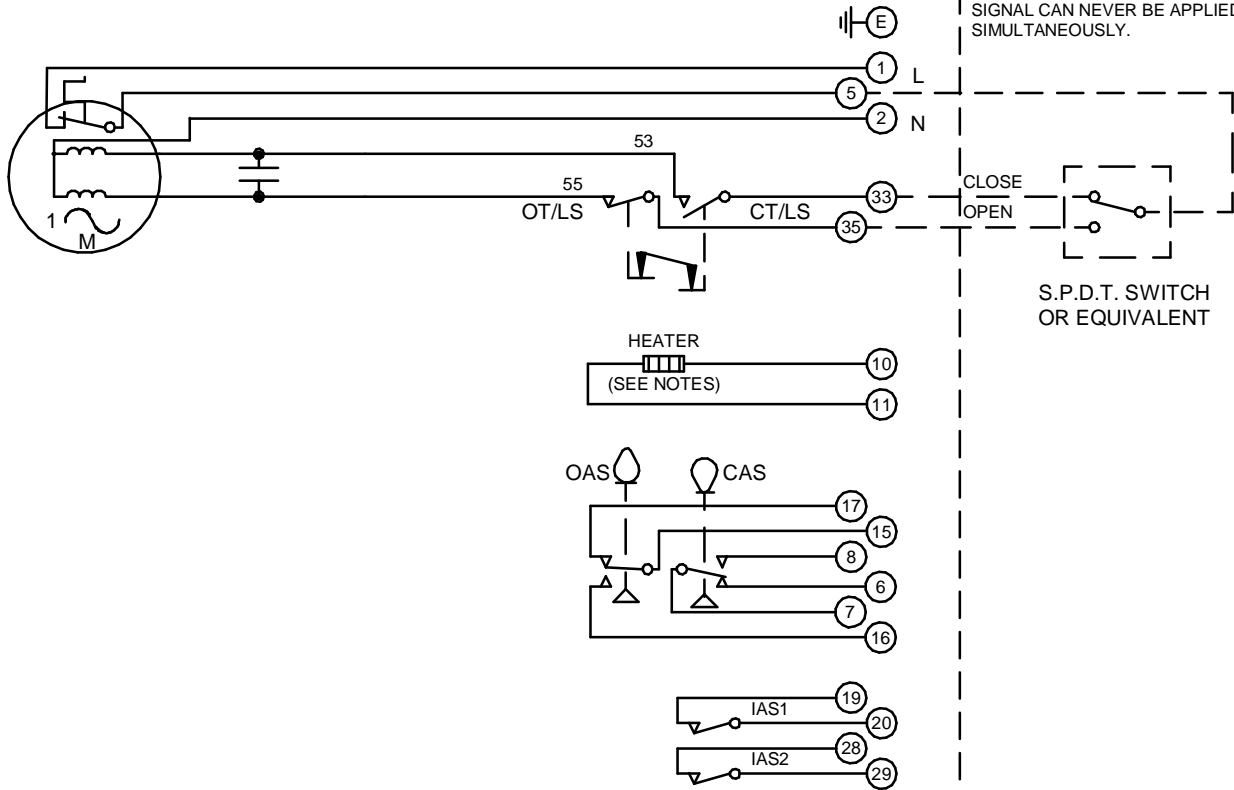

S.P.D.T. SWITCH OR EQUIVALENT

OT/LS - OPEN TORQUE/LIMIT SWITCH.

CT/LS - CLOSE TORQUE/LIMIT SWITCH.

OAS - OPEN AUXILIARY SWITCH.

CAS - CLOSE AUXILIARY SWITCH.

IAS1 & 2 - INTERMEDIATE AUXILIARY SWITCHES ADJUSTABLE TO MAKE OR BREAK INDIVIDUALLY AT ANY POSITION.

WIRES ARE IDENTIFIED AT EACH END BY TERMINAL NUMBER OR NUMBER SHOWN.

ALLOW MINIMUM 2 SECOND DELAY WHEN CONTROL SIGNALS ARE REVERSED TO ENSURE MOTOR REVERSAL.

12W (MAX) HEATER FITTED AS STANDARD. UNLESS OTHERWISE REQUESTED, HEATERS FITTED WILL BE : 120V (2K OHM) OR 240V (5.6K OHM).

Iss	Date	Chkd	Revision Details
02	190292	T.W	WARNING NOTE ADDED. CHECKED K.S 190292
03	260417	JS	PAK TERMINAL BUNG INTRODUCED FOR WTC APPLICATION EC7024.
04	240220	JS	Q GLOBAL CERTIFICATION CHANGE EC8618.

www.rotork.com

ROTORK CONTROLS LTD
 BATH, BA1 3JQ
 ENGLAND
 Tel:01225-733200

ROTORK CONTROLS INC
 ROCHESTER
 NY 14624, USA
 Tel:585-247-2304

Q - STANDARD + HEATER + 2 INTERMEDIATE SWITCHES.

Drawn by: K.S
 Date : 020490
 Base WD: 2S35Q00
 Job No : ---
 MI No : . .

Circuit Diagram No	Issue No
2S35Q00	4