

CIRCUIT IS DRAWN FOR A VALVE IN THE FULLY CLOSED POSITION

CIRCUIT IS DRAWN FOR A VALVE IN THE FULLY CLOSED POSITION

Circuit Diagram No - Issue No

2S36Q00 - 04

WARNING

IT IS ESSENTIAL THAT REMOTE CONTROL CIRCUITS ARE DESIGNED SO THAT AN OPEN AND A CLOSE SIGNAL CAN NEVER BE APPLIED SIMULTANEOUSLY.

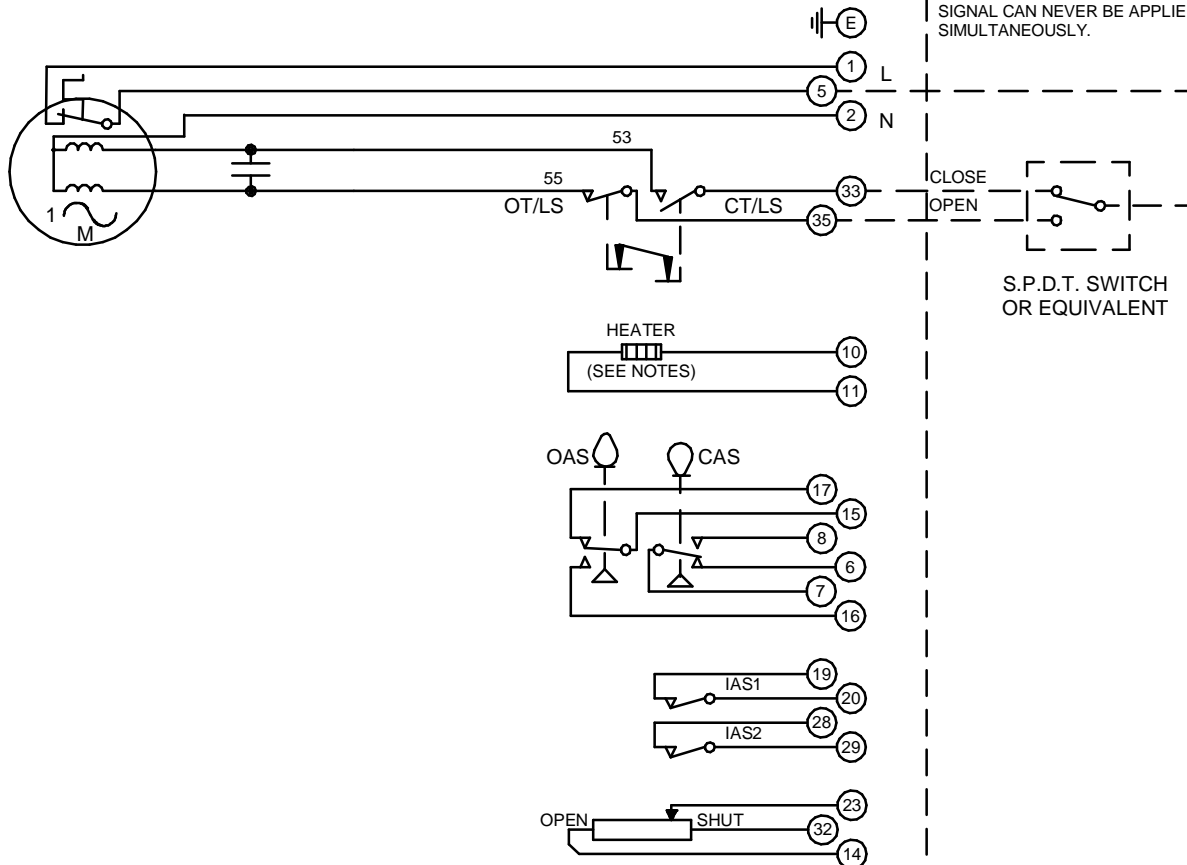

S.P.D.T. SWITCH OR EQUIVALENT

OT/LS - OPEN TORQUE/LIMIT SWITCH.

CT/LS - CLOSE TORQUE/LIMIT SWITCH.

OAS - OPEN AUXILIARY SWITCH.

CAS - CLOSE AUXILIARY SWITCH.

IAS1 & 2 - INTERMEDIATE AUXILIARY

SWITCHES ADJUSTABLE TO MAKE OR BREAK INDIVIDUALLY AT ANY POSITION.

WIRES ARE IDENTIFIED AT EACH END BY TERMINAL NUMBER OR NUMBER SHOWN.

ALLOW MINIMUM 2 SECOND DELAY WHEN CONTROL SIGNALS ARE REVERSED TO ENSURE MOTOR REVERSAL.

12W (MAX) HEATER FITTED AS STANDARD. UNLESS OTHERWISE REQUESTED, HEATERS FITTED WILL BE : 120V (2K OHM) OR 240V (5.62K OHM).

Iss	Date	Chkd	Revision Details
02	190292	T.W	WARNING NOTE ADDED. CHECKED K.S 190292
03	260417	JS	PAK TERMINAL BUNG INTRODUCED FOR WTC APPLICATION EC7024.
04	240220	JS	Q GLOBAL CERTIFICATION CHANGE EC8618.

www.rotork.com

ROTORK CONTROLS LTD BATH, BA1 3JQ ENGLAND Tel:01225-733200	ROTORK CONTROLS INC ROCHESTER NY 14624, USA Tel:585-247-2304
---	---

Q - STANDARD + HEATER + POT & 2 INTERMEDIATE SWITCHES.

Drawn by: K.S Date : 020490 Base WD: 2S36Q00 Job No : --- MI No : . .	Circuit Diagram No 2S36Q00	Issue No 4
---	---	-----------------------------