

CIRCUIT IS DRAWN FOR A VALVE IN THE FULLY CLOSED POSITION

Circuit Diagram No - Issue No

6P05Q00 - 01

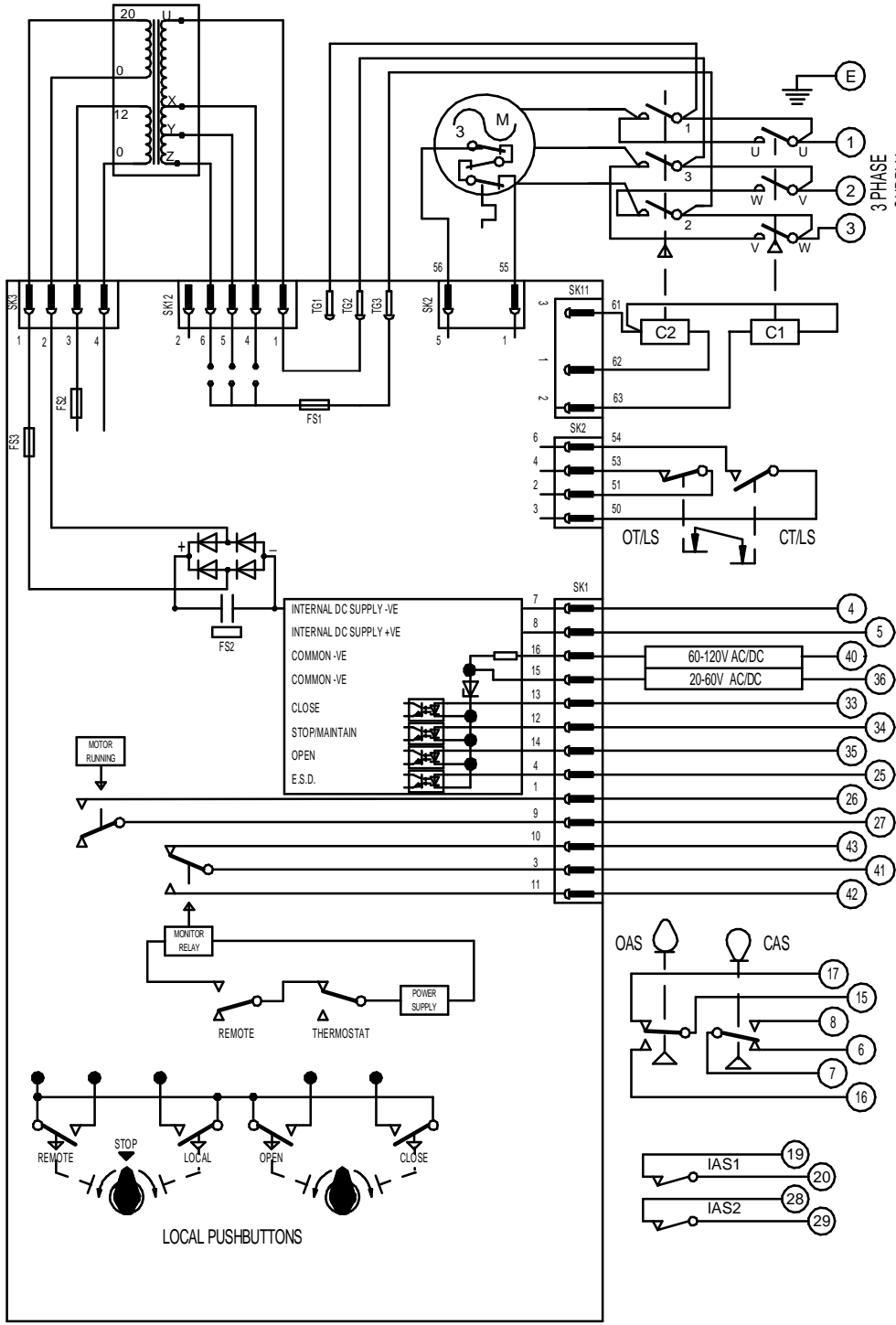

TRANSFORMER TAPPING OPTIONS

TAP	NOM50/60HZ	50HZ	60HZ
X	380/440	342-418	396-484
Y	400/460	360-440	414-506
Z	415/480	373-457	432-528

JUMPER AT LK2 FOR TAPPING X
 JUMPER AT LK3 FOR TAPPING Y
 JUMPER AT LK4 FOR TAPPING Z

OT/LS - OPEN TORQUE/LIMIT SWITCH.
 CT/LS - CLOSE TORQUE/LIMIT SWITCH.
 OAS - OPEN AUXILIARY SWITCH.
 CAS - CLOSE AUXILIARY SWITCH.
 IAS1 & 2 - INTERMEDIATE AUXILIARY SWITCHES ADJUSTABLE TO MAKE OR BREAK INDIVIDUALLY AT ANY POSITION.

WIRES ARE IDENTIFIED AT EACH END BY TERMINAL NUMBER OR NUMBER SHOWN.

FS1 - 100 mA
 FS2 - 1 A
 FS3 - 250 mA
 TERMINALS 4 & 5 FUSED INTERNALLY AT 160mA

E.S.D. CONTROL SIGNAL VOLTAGE MUST BE EQUAL TO OR GREATER THAN ALL OTHER CONTROL SIGNAL VOLTAGES.

Iss	Date	Chkd	Revision Details
01	301219	JS	FIRST ISSUE

www.rotork.com

ROTORK CONTROLS (INDIA) PRIVATE LTD
 28B, AMBATTUR INDUSTRIAL ESTATE (NORTH),
 AMBATTUR, CHENNAI - 600 098 INDIA.
 Tel:044-39555600

BASIC Q-PAK. + 2 INTERMEDIATE SW

Drawn by: JS
 Date : 301219
 Base WD:
 Job No : --
 MI No : .

Circuit Diagram No	Issue No
6P05Q00	1