

CIRCUIT DRAWN WITH POWER SUPPLY OFF
 PLUG SELECTED VOLTAGE WIRE INTO TERMINAL "T"
 PLACE TWO REMAINING WIRES INTO POSITIONS "P"
 (ORDER NOT IMPORTANT)

FOR TYPICAL REMOTE CONTROL
 DETAILS, SEE DOCUMENT
RWS104

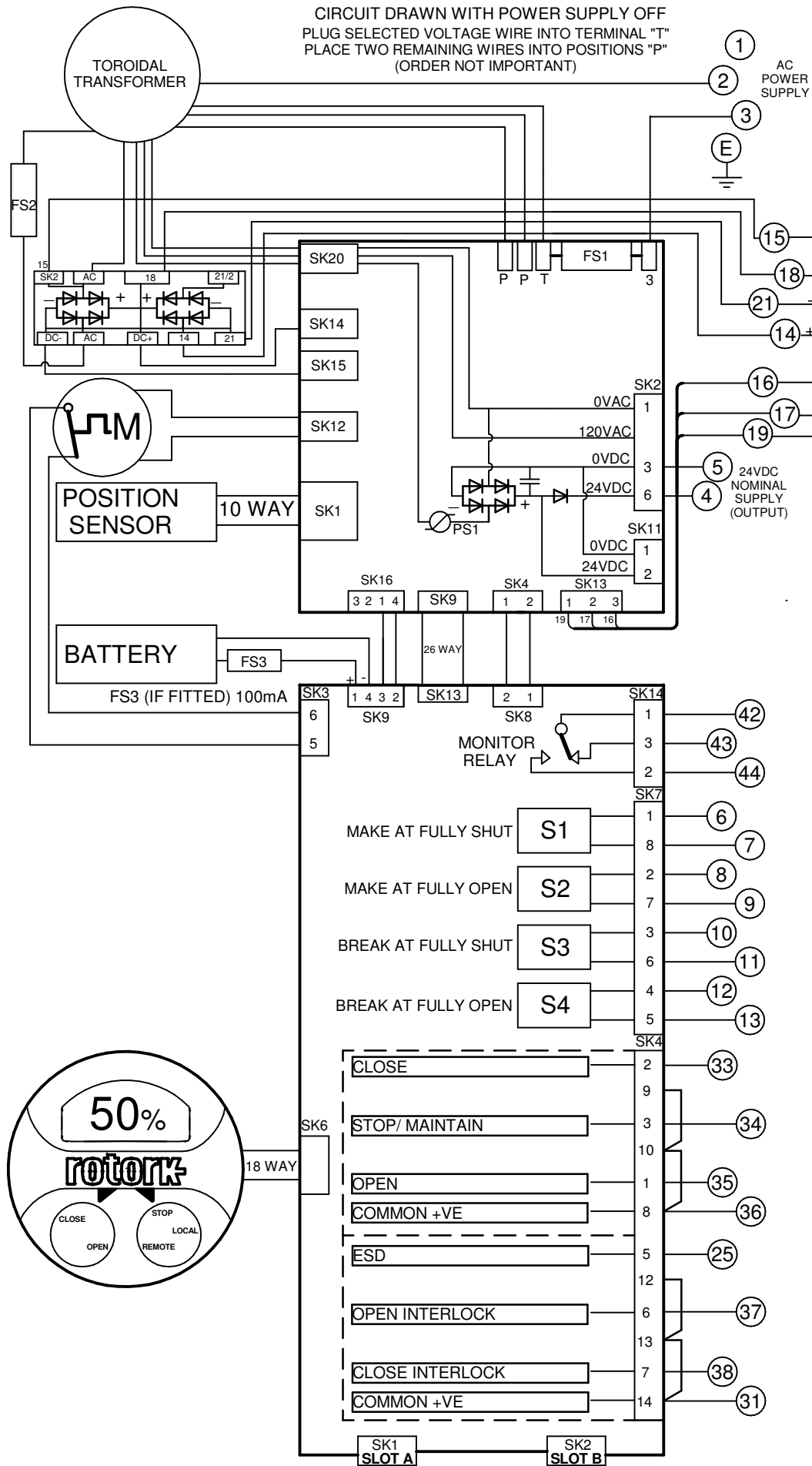

TRANSFORMER VOLTAGE OPTIONS:
 CONNECT CORRESPONDING
 COLOUR TO "T"

| TYPE 1 | | |
|--------|------|-------------------------|
| GREY | 100V | FS1 - 5A ANTISURGE |
| PURPLE | 110V | |
| BROWN | 120V | |
| TYPE 2 | | |
| GREY | 200V | FS1 - 2.5A ANTISURGE |
| PURPLE | 230V | |
| BROWN | 270V | |
| TYPE 3 | | |
| GREY | 380V | FS1 - 2.0A ANTISURGE |
| PURPLE | 400V | |
| BROWN | 415V | |
| TYPE 4 | | |
| GREY | 480V | FS1 - 2.0A ANTISURGE |
| PURPLE | 575V | |
| BROWN | 690V | |

FS2 - 20A ATO FAST ACTING ALL TYPES

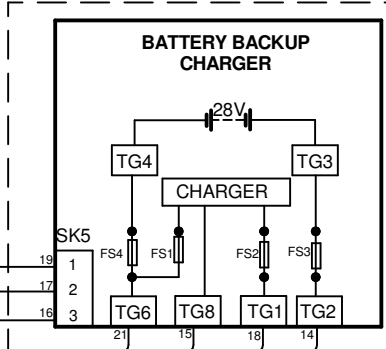

BATTERY PACK
 FOR DETAILS SEE PUBLICATION PUB002-105
 FS3, FS4 - 20A ATO FAST ACTING
 FS1, FS2 - 2A 20mm QUICK BLOW
 FAILSAFE OPERATION, ON LOSS OF 3-PHASE,
 CUSTOMER SUPPLY ON 4 & 5 IS ALSO LOST.

REFER TO SHEET 2 FOR NOTES
 & OPTION PCB'S IF FITTED

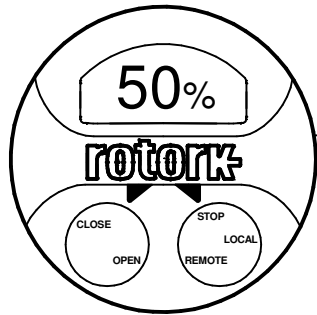

| | | | | | | | | | |
|-------------|----------------|-------------|----------------------------------|---|---|---|---|----------------------|---------------------------|
| Iss 1 | Date 280420 | Chkd JC1 | Revision Details First Issue. | www.rotork.com ROTORK CONTROLS LTD BATH, BA1 3JQ ENGLAND Tel:01225-733200 | ROTORK CONTROLS INC ROCHESTER NY 14624, USA Tel:585-247-2304 | IQT FAILSAFE BATTERY BACKUP + NEGATIVE SWITCHING REMOTES Drawn by: PJW Date : 280420 Base WD: 390B0100 Job No : - - MI No : - - | Circuit Diagram Number 390B0100 | Issue No 1 | Sheet 1 of 2 |
| B1 C1 B2 C2 | | | | | | | | | |

NO OPTIONS FITTED

NOTES

1.FUSES:

- PS1 is a self-resetting fuse.
- Refer to publication PUB002-065 for approved fuses FS1 and FS2.
- Actuator rated voltage specified on nameplate. Voltage tolerance +/-10% applies for rated torque performance; duty cycle is not guaranteed.

2.REMOTE CONTROL:

- For typical remote control circuits refer to:
 - RWS indicated or PUB002-041.
- For DC and AC control, connect -ve/0V to terminal 36.
- (For negative switch / positive common, refer to RWS indicated).
- Control signal threshold voltages:
 - DC: "on" $\geq 16\text{Vdc}$ / "off" $\leq 8\text{Vdc}$, max 60Vdc.
 - AC: "on" $\geq 60\text{Vac}$ / "off" $\leq 40\text{Vac}$, max 120Vac.
- Control signal duration to be 300ms minimum.
- Maximum current drawn from remote control signals is:
 - 8mA at 24Vdc or 12mA at 120Vac.
- Supply provided on terminals 4 & 5:
 - Intended for remote control.
 - Max external load 5W at 24Vdc / 5VA at 120Vac

3.INDICATION:

- For typical position, status and alarm indication see PUB002-041.
- "S" contacts are user configurable and are shown in their default setting.
- Refer to PUB002-040 for functions and configuration instructions.
- Monitor Relay indicates actuator availability for remote control (shown "unavailable"). It can be configured to exclude local/remote selection.
- Refer to PUB002-040 for monitored functions and configuration instructions.
- Voltage applied to indication contacts must not exceed 150Vac
- Individual Switch current must not exceed 3.5A inductive, 5A resistive and no more than 8A in total for all 4 contacts.

4.BATTERY:

- Battery maintains local and remote "S" contact indication only.
- Refer to installation manual for approved replacement battery types.