

H
G
F
E
D
C
B
A

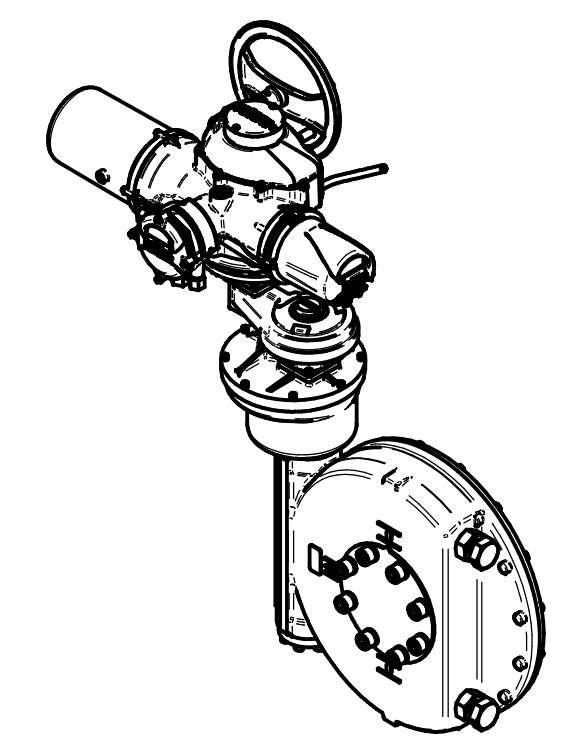

NOTES:
 : DIMENSIONS WITH "*" INDICATE COVER REMOVAL ALLOWANCE
 : NETT WEIGHT = 721kg/1589lbs
 : = OIL FILLER/DRAIN PLUG
 : THE INTERFACE PROVIDED FOR MOUNTING THE ACTUATOR OR SECOND STAGE GEARBOX ONTO THE VALVE SHOULD CONFORM TO GOOD ENGINEERING PRACTICES, ENSURING ADEQUATELY TOLERANCED LIMITS FOR PARALLELISM, PERPENDICULARITY AND CONCENTRICITY.
 : ROTORK CANNOT BE HELD LIABLE FOR DAMAGE TO OUR EQUIPMENT CAUSED BY EXCESSIVE LOADING FROM COVER TUBES. (SEE ALSO PUB000-124)

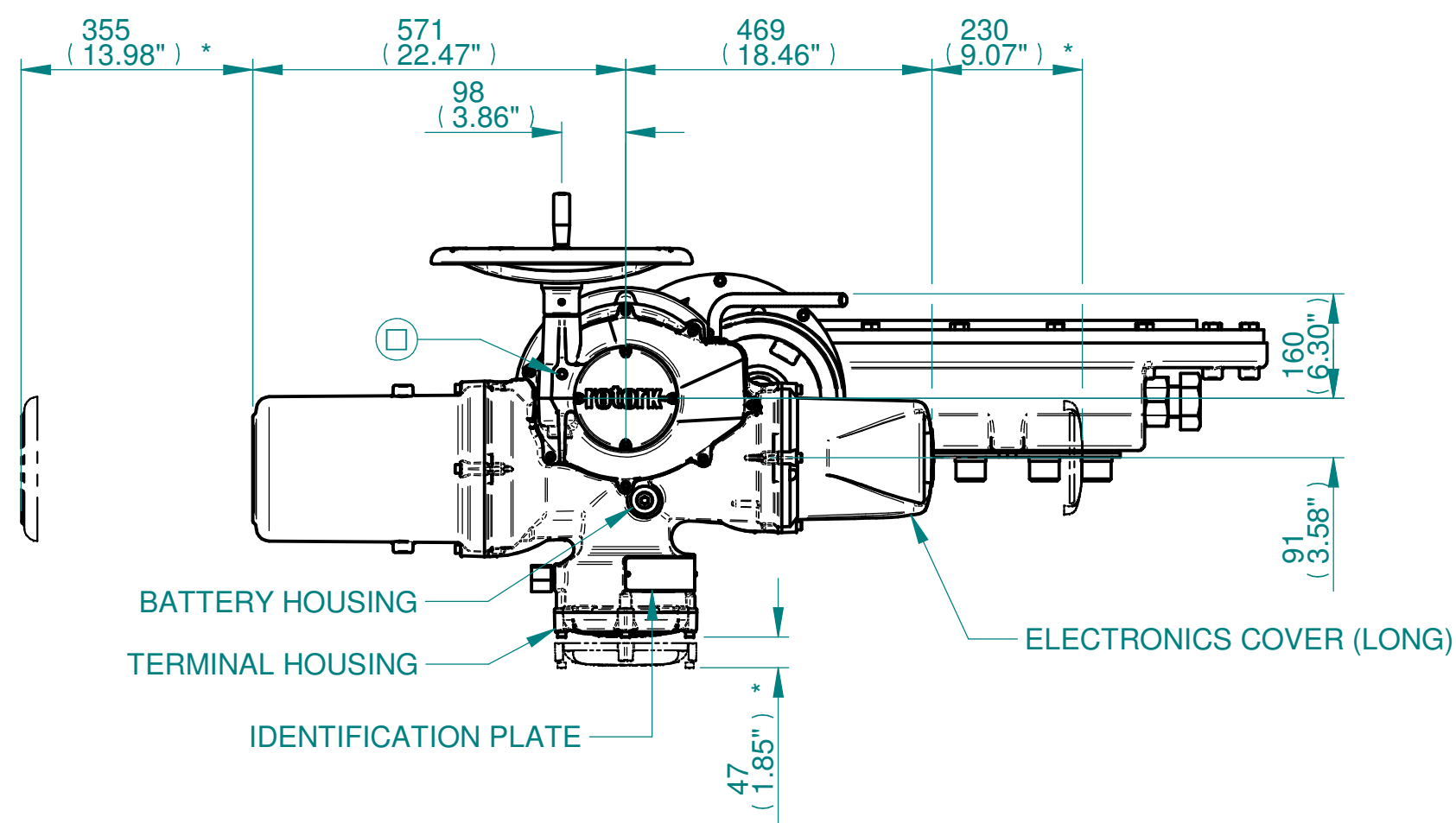
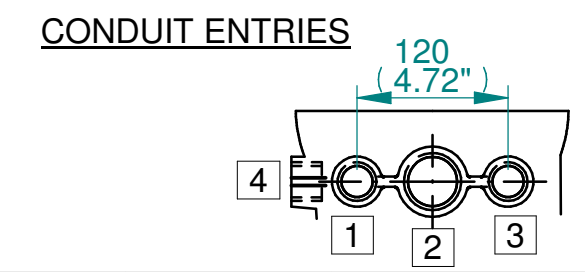

	Hole 1	Hole 2	Hole 3	Hole 4
Size	As Required	As Required	As Required	As Required
Plugged	As Required	As Required	As Required	As Required
Gland	As Required	As Required	As Required	As Required

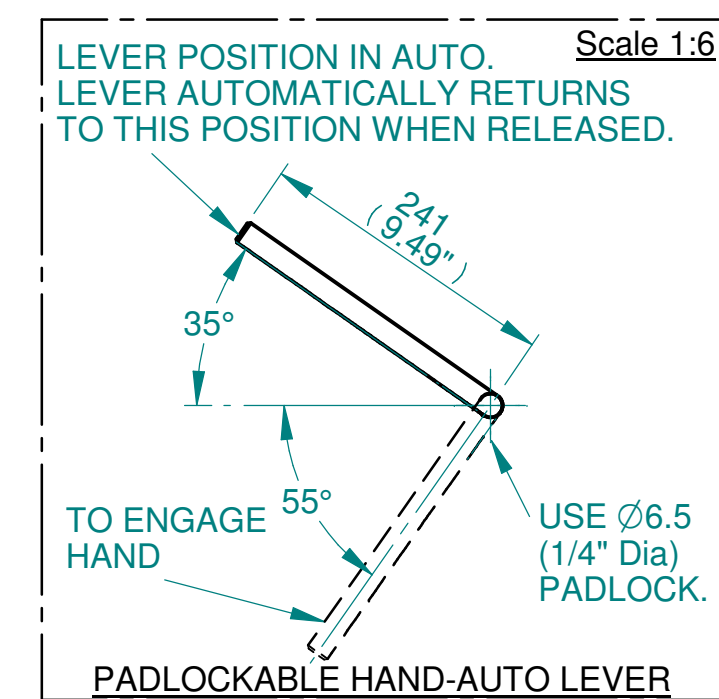
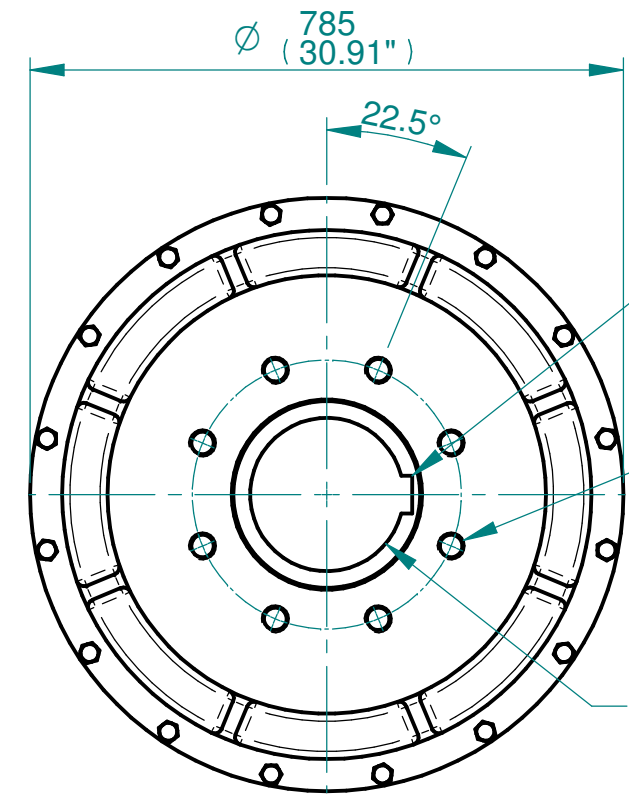
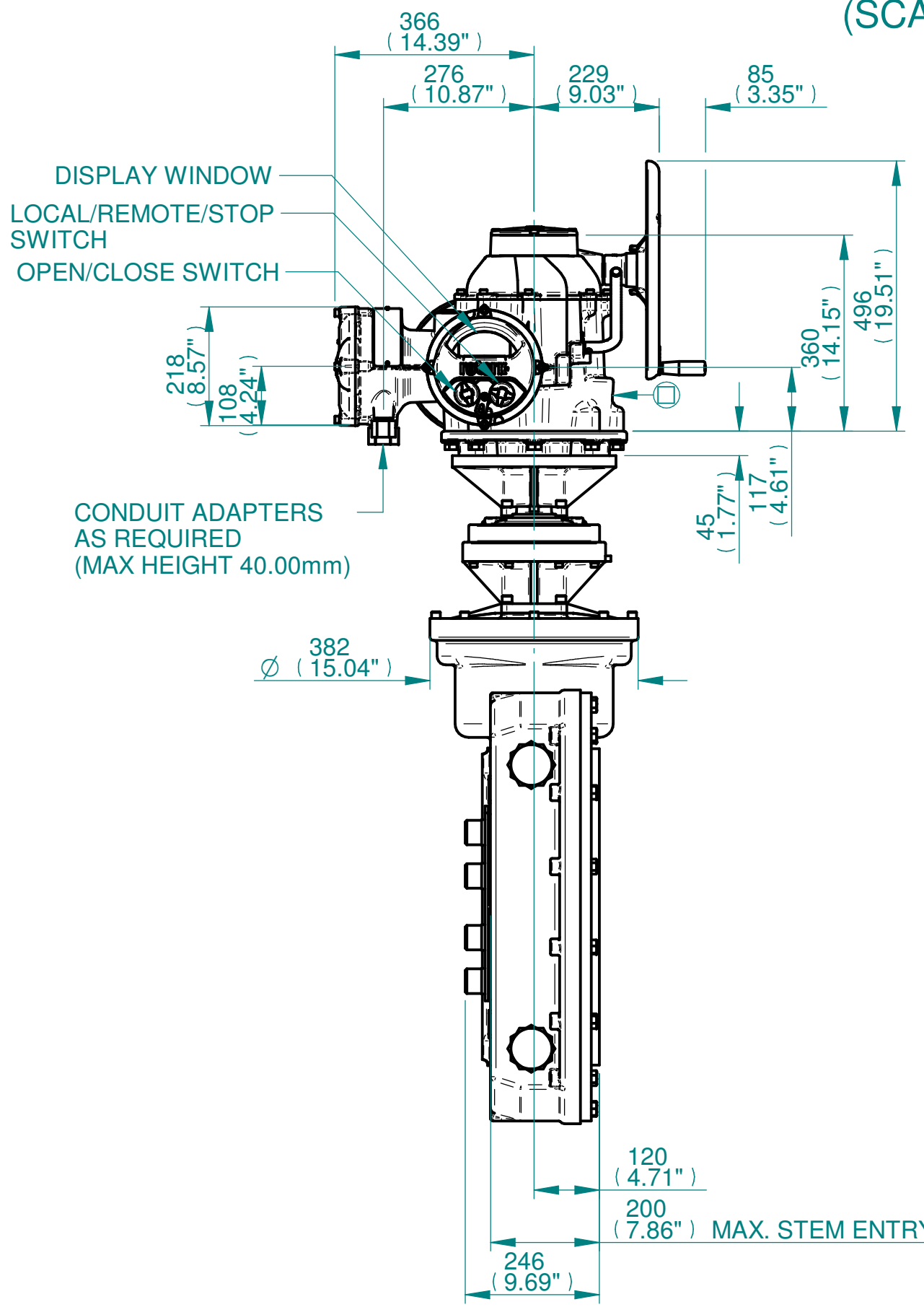
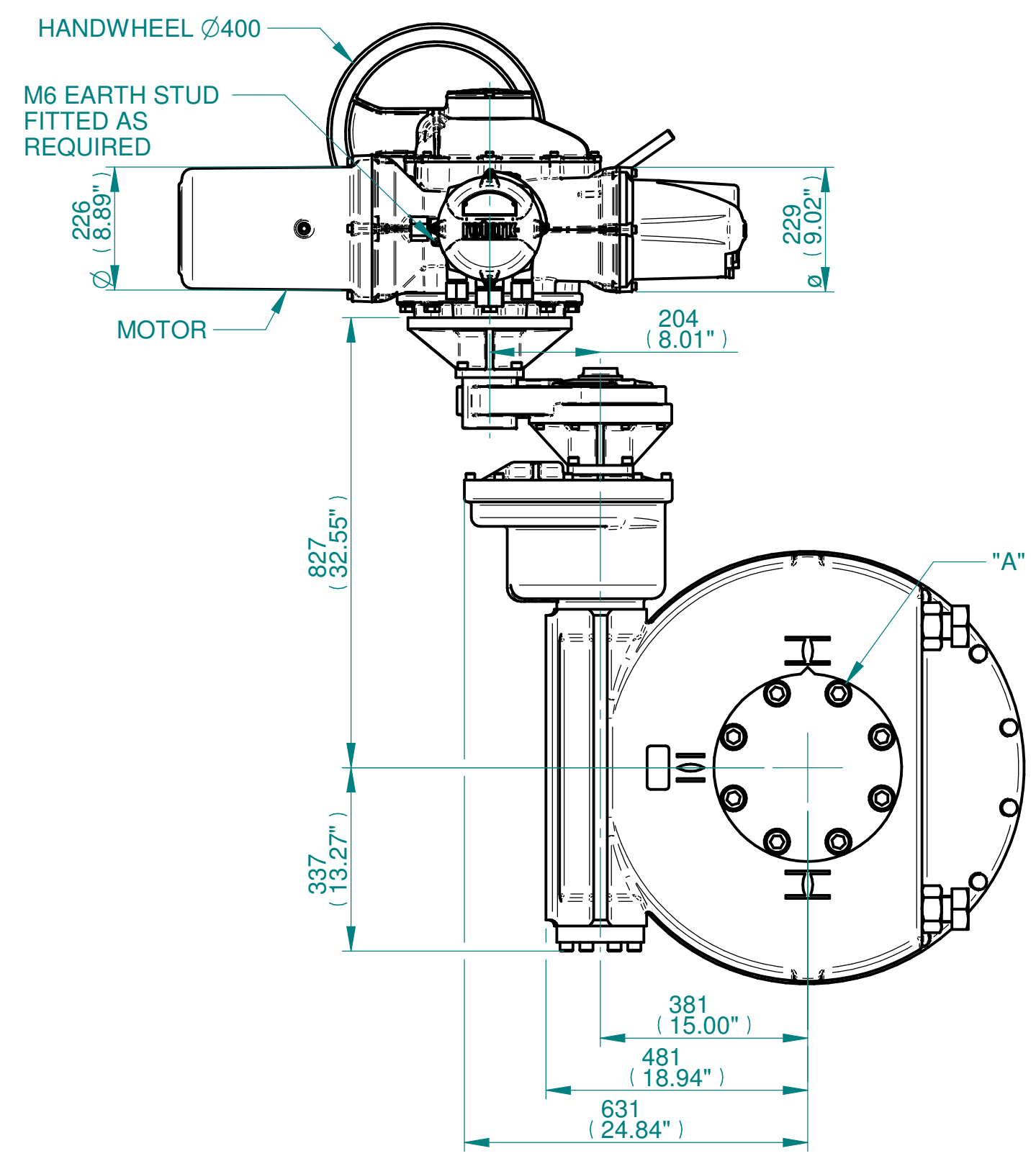

3D Models are available in various formats under the same drawing number

Actuator Size: IQ91 IW115 & 116IR35AS5		Gearbox output flange options								Maximum Bore & Key			
Title	IQ91, SIDE HANDWHEEL, IW115IR35AS5 / IW116IR35AS5, F/FA35, 40 & 48 Ratios 1190 - 6560:1 Installation Details	Designation	F35	F40	F48	-	FA35	FA40	FA48	-	Key form	Ø Bore	Key size
Drawn	TED	Checked	NJC	Date	18-AUG-14	No. Holes	8	8	12 NOT SHOWN	-	Rectangle (BS4235)	270	63 X 32
Hole size	M30	M36	M36	-	1" UNC	1-1/4" UNC	1-1/4" UNC	-	Rectangle (ANSI B17.1)	7-5/8"	2 X 1-1/2"		
PCD	356	406	483	-	14"	16"	19"	-	Square (ANSI B17.1)	7-3/8"	1-3/4" SQ		

Issue	Description
2	OUTPUT FLANGE CHANGE

Scale: 1:10 THIRD ANGLE PROJECTION

Drawing Number	Issue No	Sheet No
115-91-SHWIW115IR35AS5STD	2	1 of 1

rotork
www.rotork.com
Rotork Controls Limited
Bath, BA1 3JQ, England.
Telephone 01225-733200

1 2 3 4 5 6 7 8 9 10 11 12