

FOR TYPICAL REMOTE CONTROL DETAILS, SEE DOCUMENT **RWS122**

Tap	Nominal 50/60Hz
TYPE 1	
W	220/230
X	380/400
Y	400,415/420
Z	440/460
FUSE FS 1=250mA ANTI-SURGE	
TYPE 2	
W	346/380
X	480/500
Y	240/240
Z	550/575
FUSE FS 1=250mA ANTI-SURGE	
TYPE 3	
X	660/660-690
Y	690/-
FUSE FS 1=150mA ANTI-SURGE	

REFER TO SHEET 2 FOR NOTES & OPTION PCB'S IF FITTED



FS2 (IF FITTED) 100mA

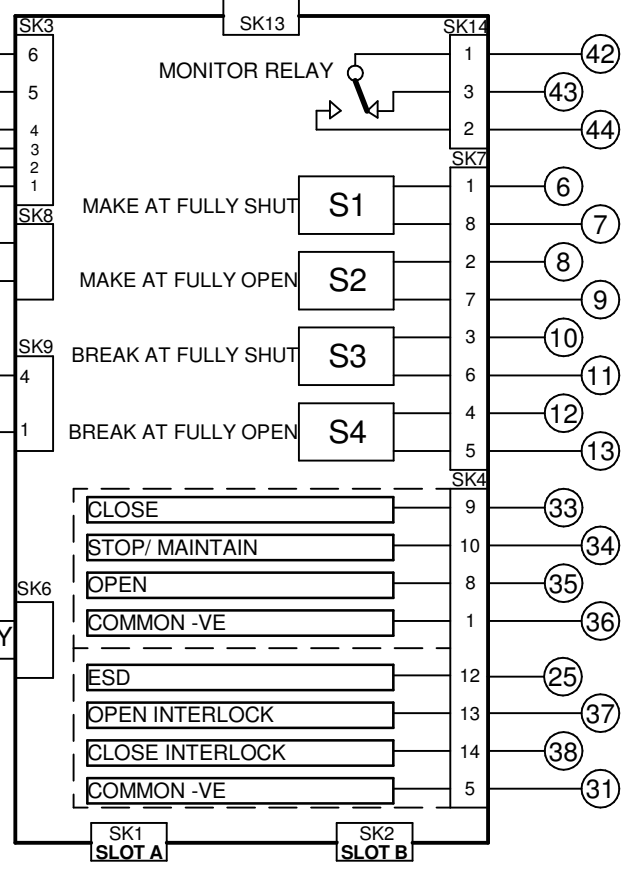
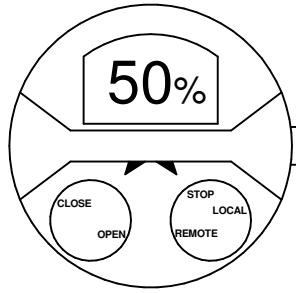

Iss	Date	Chkd	Revision Details
1	020920	JC1	First Issue

www.rotork.com

ROTORK CONTROLS LTD
BATH, BA1 3JQ
ENGLAND
Tel:01225-733200

ROTORK CONTROLS INC
ROCHESTER
NY 14624, USA
Tel:585-247-2304

IQ + MODBUS REPEATER MODULE + FOLOMATIC / CPT.		Circuit Diagram Number		Issue No	Sheet
		103M4000		1	1
B1	C1	B2	C2		of 2

SLOT A

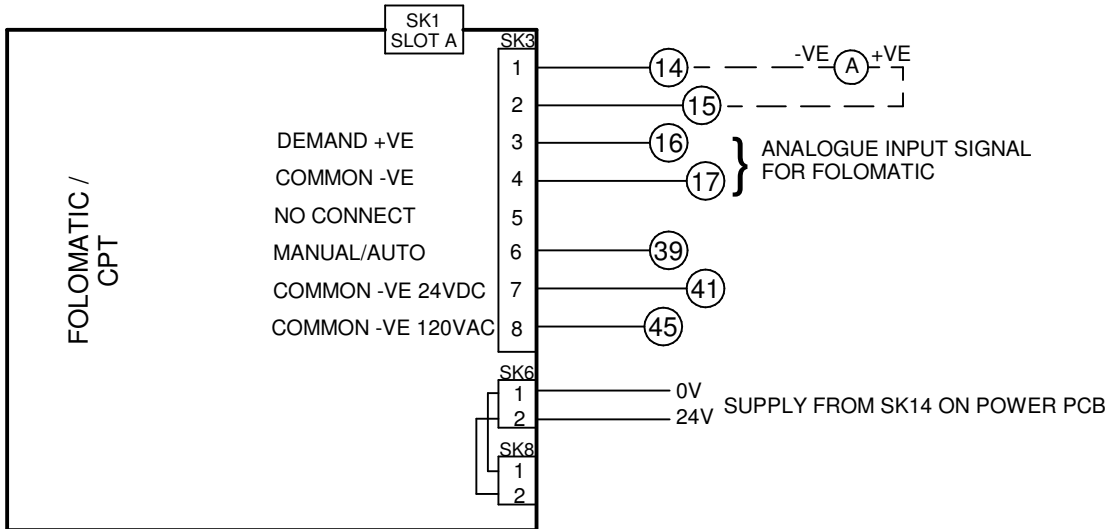

FOR MANUAL/AUTO CONNECTIONS AND
DETAILS OF FOLOMATIC/CPT FUNCTIONS
REFER TO ROTORK PUBLICATION PUB002-041

SLOT B

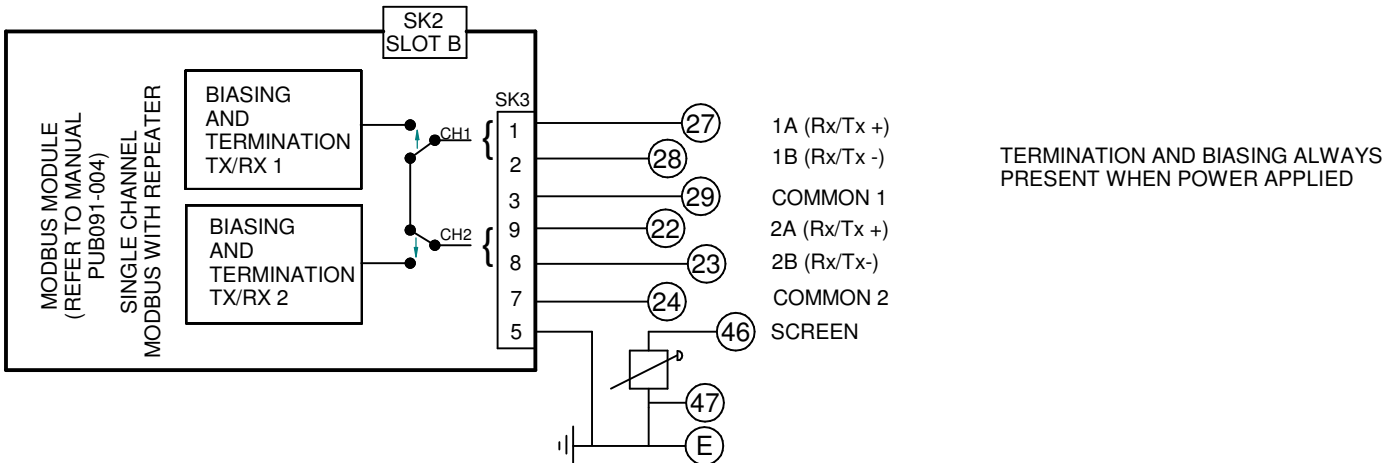

NOTES

- FUSES:** PS1 IS A SELF RESETTING FUSE. REFER TO PUBLICATION PUB002-039 FOR APPROVED FUSES FS1 AND FS2. ACTUATOR RATED VOLTAGE SPECIFIED ON NAMEPLATE. VOLTAGE TOLERANCE +/-10%, APPLIES FOR RATED TORQUE PERFORMANCE; DUTY CYCLE IS NOT GUARANTEED.
- REMOTE CONTROL:** FOR TYPICAL REMOTE CONTROL CIRCUITS REFER TO RWS INDICATED OR PUBLICATION PUB002-041. FOR DC AND AC CONTROL CONNECT -VE/0V TO TERMINAL 36 (FOR NEGATIVE SWITCH / +VE COMMON WIRING DIAGRAMS, REFER TO RWS INDICATED). DC CONTROL SIGNAL THRESHOLD VOLTAGES - "ON" ≥16VDC / "OFF" ≤ 8VDC. AC CONTROL SIGNAL THRESHOLD VOLTAGES - "ON" ≥60VAC / "OFF" ≤ 40VAC. CONTROL SIGNAL DURATION TO BE 300ms MINIMUM. MAXIMUM CURRENT DRAWN FROM REMOTE CONTROL SIGNALS IS 8mA AT 24VDC OR 12mA AT 120VAC. SUPPLY PROVIDED ON TERMINALS 4 & 5 IS INTENDED FOR REMOTE CONTROL. MAX EXTERNAL LOAD ON TERMINALS 4 & 5 IS 5W AT 24VDC / 5VA AT 120VAC.

- INDICATION:** FOR TYPICAL, POSITION, STATUS AND ALARM INDICATION SEE PUBLICATION PUB002-041. "S" CONTACTS ARE USER CONFIGURABLE AND ARE SHOWN IN THEIR DEFAULT SETTING. REFER TO PUB002-040 FOR FUNCTIONS AND CONFIGURATION INSTRUCTIONS. MONITOR RELAY INDICATES ACTUATOR AVAILABILITY FOR REMOTE CONTROL (SHOWN "UNAVAILABLE"). IT CAN BE CONFIGURED TO EXCLUDE LOCAL/REMOTE SELECTION. REFER TO PUB002-040 FOR MONITORED FUNCTIONS AND CONFIGURATION INSTRUCTIONS. VOLTAGE APPLIED TO INDICATION CONTACTS MUST NOT EXCEED 150V. MAX SWITCHES CURRENT NOT TO EXCEED 3.5A INDUCTIVE, 5A RESISTIVE.
- BATTERY:** BATTERY MAINTAINS LOCAL AND REMOTE "S" CONTACT INDICATION ONLY. REFER TO INSTALLATION MANUAL FOR APPROVED REPLACEMENT BATTERY TYPES.