

CIRCUIT DRAWN WITH POWER SUPPLY OFF

FOR TYPICAL REMOTE CONTROL
DETAILS, SEE DOCUMENT
RWS100

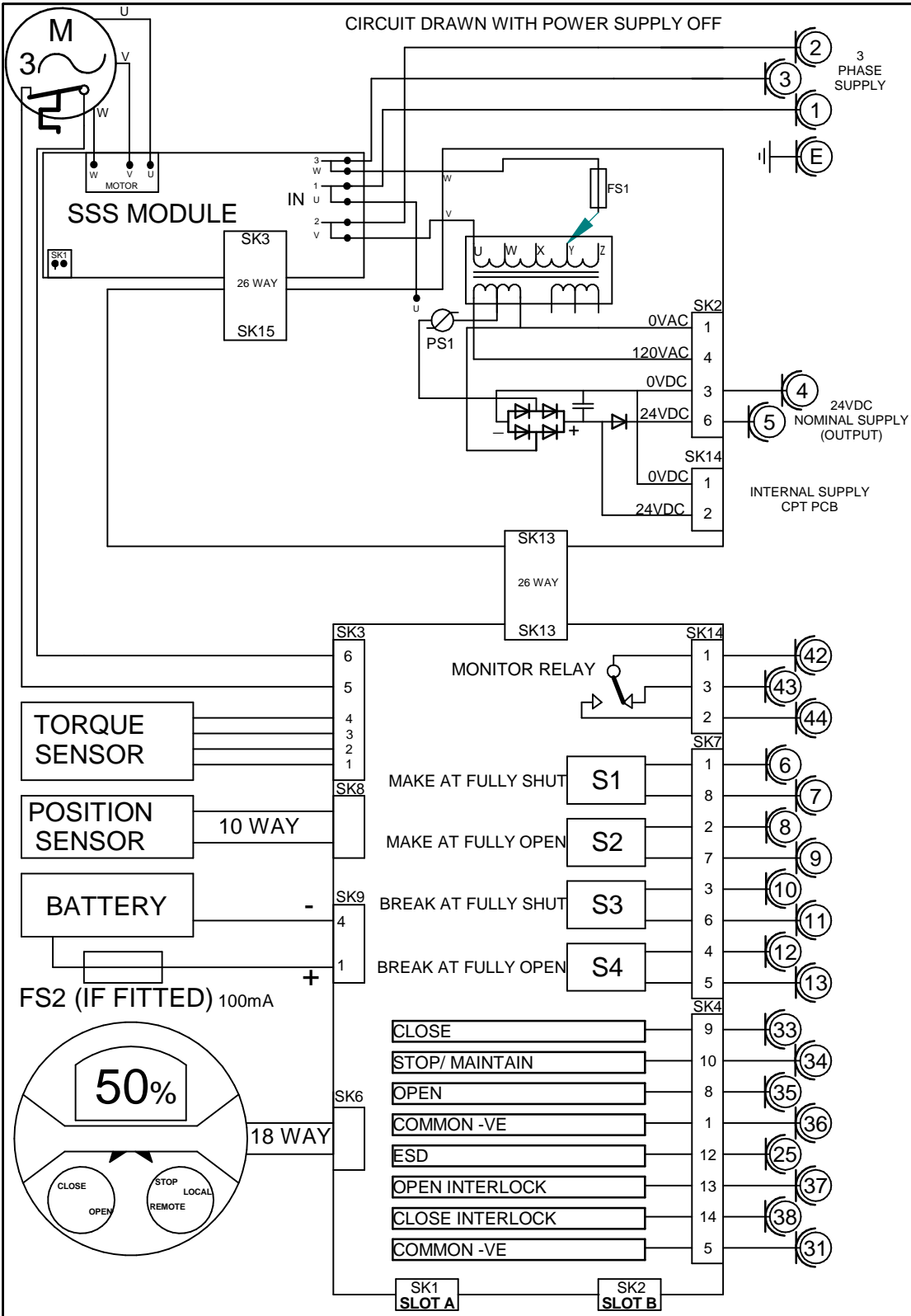

TRANSFORMER TAPPING OPTIONS	
Tap	Nominal 50/60Hz
TYPE 1	
W	220/230
X	380/400
Y	415/420
Z	440/460
FUZE FS1=250mA ANTI-SURGE	
TYPE 2	
W	346/380
X	480/500
Y	240/240
Z	550/575
FUZE FS1=250mA ANTI-SURGE	

REFER TO SHEET 2 FOR NOTES
& OPTION PCB'S IF FITTED

THE ACTUATOR MUST BE
PROTECTED USING SUITABLY
RATED HIGH SPEED
SEMI-CONDUCTOR FUSES ON THE
INCOMING SUPPLY.
SUGGESTED FUSES :-
IQM10-20:10 Amp FERRAZ G330010
IQM25-35:20 Amp FERRAZ K330013
ALTERNATIVES =
IQM10-20:10 Amp SIBA 50-179-06/10A
IQM25-35:20 Amp SIBA 50-179-06/20A
OR EQUIVALENT PROTECTIVE
DEVICE.

PLUG & SOCKET CONNECTION

Iss 1	Date 131020	Chkd JC1	Revision Details First Issue.	www.rotork.com	IQM + CPT + PLUG & SOCKET			
					ROTORK CONTROLS LTD BATH, BA1 3JQ ENGLAND Tel:01225-733200	ROTORK CONTROLS INC ROCHESTER NY 14624, USA Tel:585-247-2304	Drawn by: PJW Date : 131020 Base WD: 201B0002 Job No : -- MI No : --	Circuit Diagram Number 201B0002

SLOT A

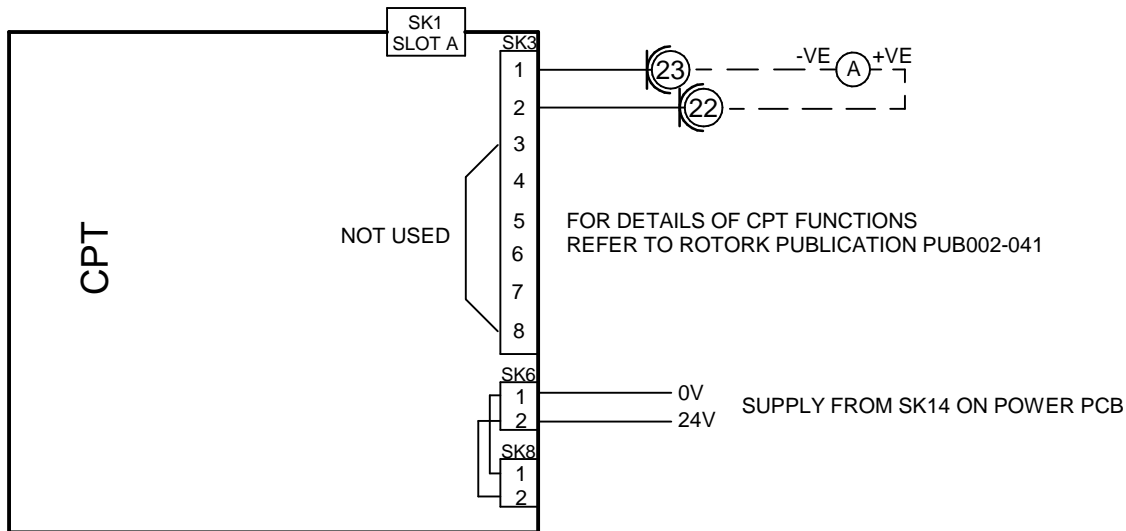

FOR MANUAL/AUTO CONNECTIONS AND
DETAILS OF FOLOMATIC/CPT FUNCTIONS
REFER TO ROTORK PUBLICATION PUB002-041

NOTES

1.FUSES:

- PS1 is a self-resetting fuse.
- Refer to publication PUB002-039 for approved fuses FS1 and FS2.
- Actuator rated voltage specified on nameplate. Voltage tolerance +/-10%, applies for rated torque performance; duty cycle is not guaranteed.

2.REMOTE CONTROL:

- For typical remote control circuits refer to:
 - RWS indicated or PUB002-041.
- For DC control connect -ve to terminal 36.
- (For negative switch / positive common, refer to RWS indicated).
- Control signal threshold voltages:
 - DC: "on" $\geq 16Vdc$ / "off" $\leq 8Vdc$, max 60Vdc.
- Control signal duration to be 100ms minimum.
- Maximum current drawn from remote control signals is:
 - 8mA at 24Vdc.
- Supply provided on terminals 4 & 5:
 - Intended for remote control.
 - Max external load 5W at 24Vdc

3.INDICATION:

- For typical position, status and alarm indication see PUB002-041.
- “S” contacts are user configurable and are shown in their default setting.
- Refer to PUB002-040 for functions and configuration instructions.
- Monitor Relay indicates actuator availability for remote control (shown “unavailable”). It can be configured to exclude local/remote selection.
- Refer to PUB002-040 for monitored functions and configuration instructions.
- Voltage applied to indication contacts must not exceed 150Vac.
- Individual Switch current must not exceed 3.5A inductive, 5A resistive and no more than 8A in total for all 4 contacts.

4.BATTERY:

- Battery maintains local and remote “S” contact indication only.
- Refer to installation manual for approved replacement battery types.