

CIRCUIT DRAWN WITH POWER SUPPLY OFF  
 PLUG SELECTED VOLTAGE WIRE INTO TERMINAL "T"  
 PLACE TWO REMAINING WIRES INTO POSITIONS "P"  
 (ORDER NOT IMPORTANT)

FOR TYPICAL REMOTE CONTROL  
 DETAILS, SEE DOCUMENT  
**RWS100**

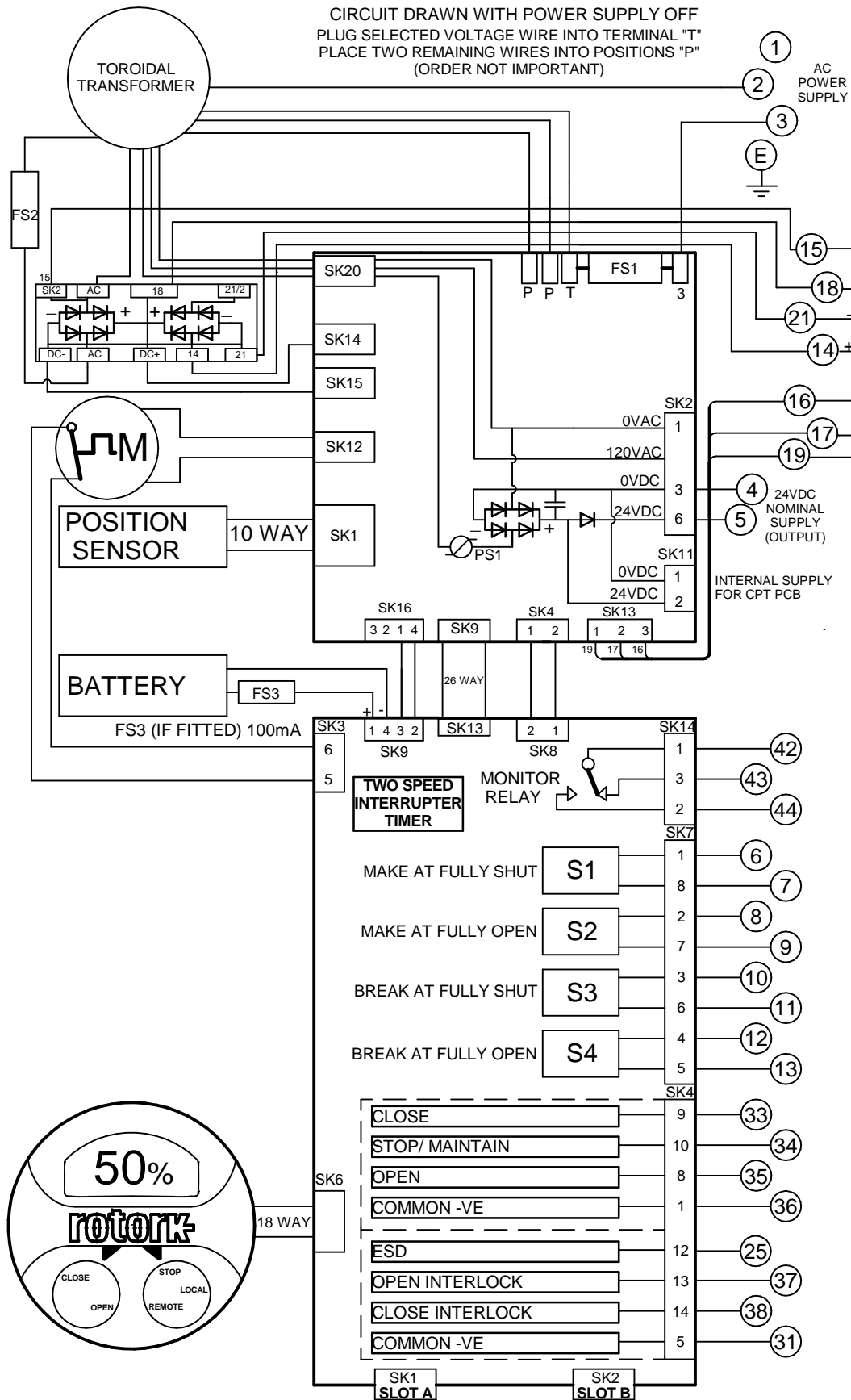

TRANSFORMER VOLTAGE OPTIONS:  
 CONNECT CORRESPONDING  
 COLOUR TO "T"

TYPE 1		
GREY	100V	FS1 - 5A ANTISURGE
PURPLE	110V	
BROWN	120V	
TYPE 2		
GREY	200V	FS1 - 2.5A ANTISURGE
PURPLE	230V	
BROWN	270V	
TYPE 3		
GREY	380V	FS1 - 2.0A ANTISURGE
PURPLE	400V	
BROWN	415V	
TYPE 4		
GREY	480V	FS1 - 2.0A ANTISURGE
PURPLE	575V	
BROWN	690V	

FS2 - 20A ATO FAST ACTING ALL TYPES

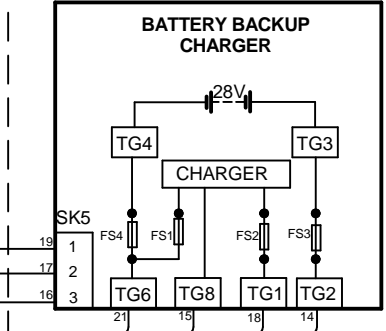

**BATTERY PACK**  
 FOR DETAILS SEE PUBLICATION PUB002-105  
 FS3, FS4 - 20A ATO FAST ACTING  
 FS1, FS2 - 2A 20mm QUICK BLOW  
 FAILSAFE OPERATION, ON LOSS OF 3-PHASE  
 CUSTOMER SUPPLY ON 4 & 5 IS ALSO LOST.

REFER TO SHEET 2 FOR NOTES  
 & OPTION PCB'S IF FITTED

Iss	Date	Chkd	Revision Details
1	080121	JC1	First Issue.

**www.rotork.com**

ROTORK CONTROLS LTD BATH, BA1 3JQ ENGLAND Tel:01225-733200	ROTORK CONTROLS INC ROCHESTER NY 14624, USA Tel:585-247-2304
---	---

IQT FAILSAFE BATTERY BACKUP + CPT+ EXTRA RELAYS S5-S8 + TIMER		Circuit Diagram Number <b>391B0011</b>	Issue No <b>1</b>	Sheet <b>1</b> of 2			
B1	C1	B2	C2	B1	C1	M1	V1

## SLOT A

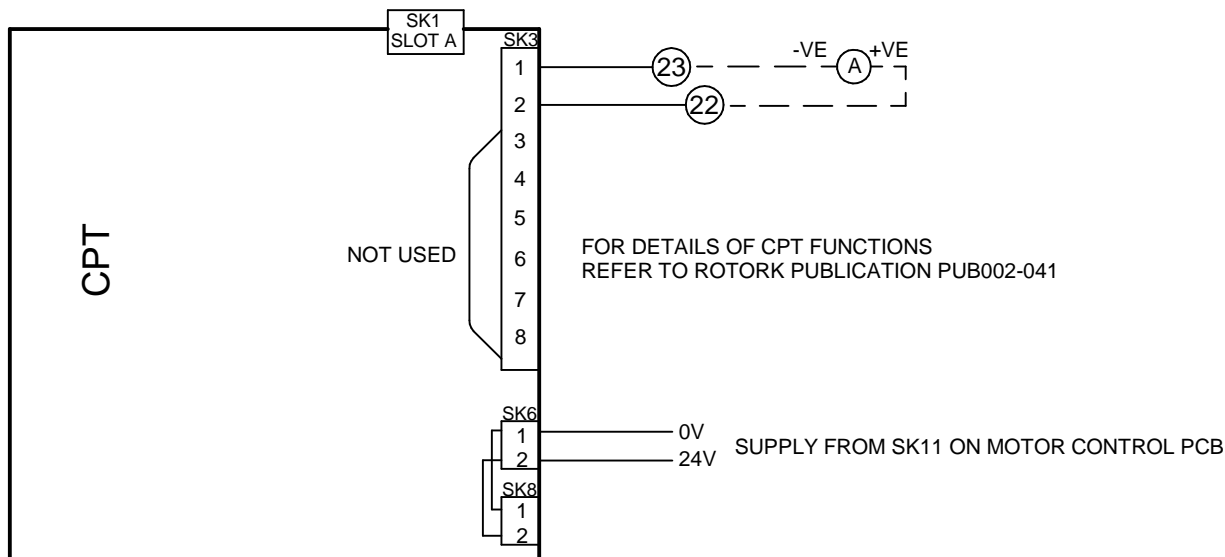

## SLOT B

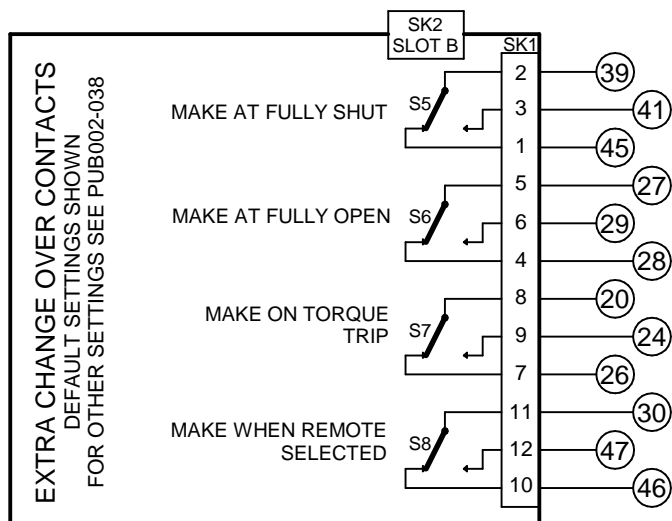

### NOTES

#### 1.FUSES:

- PS1 is a self-resetting fuse.
- Refer to publication PUB002-065 for approved fuses FS1 and FS2.
- Actuator rated voltage specified on nameplate. Voltage tolerance +/-10% applies for rated torque performance; duty cycle is not guaranteed.

#### 2.REMOTE CONTROL:

- For typical remote control circuits refer to:
  - RWS indicated or PUB002-041.
- For DC and AC control, connect -ve/0V to terminal 36.
- (For negative switch / positive common, refer to RWS indicated).
- Control signal threshold voltages:
  - DC: "on" ≥16Vdc / "off" ≤8Vdc, max 60Vdc.
  - AC: "on" ≥60Vac / "off" ≤40Vac, max 120Vac.
- Control signal duration to be 300ms minimum.
- Maximum current drawn from remote control signals is:
  - 8mA at 24Vdc or 12mA at 120Vac.
- Supply provided on terminals 4 & 5:
  - Intended for remote control.
  - Max external load 5W at 24Vdc / 5VA at 120Vac

#### 3.INDICATION:

- For typical position, status and alarm indication see PUB002-041.
- "S" contacts are user configurable and are shown in their default setting.
- Refer to PUB002-040 for functions and configuration instructions.
- Monitor Relay indicates actuator availability for remote control (shown "unavailable"). It can be configured to exclude local/remote selection.
- Refer to PUB002-040 for monitored functions and configuration instructions.
- Voltage applied to indication contacts must not exceed 150Vac
- Individual Switch current must not exceed 3.5A inductive, 5A resistive and no more than 8A in total for all 4 contacts.

#### 4.BATTERY:

- Battery maintains local and remote "S" contact indication only.
- Refer to installation manual for approved replacement battery types.