

FOR TYPICAL REMOTE CONTROL  
DETAILS, SEE DOCUMENT  
**RWS100**

PLUG SELECTED VOLTAGE WIRE INTO  
TERMINAL "T"  
PLACE TWO REMAINING WIRES INTO  
POSITIONS "P"  
(ORDER NOT IMPORTANT)

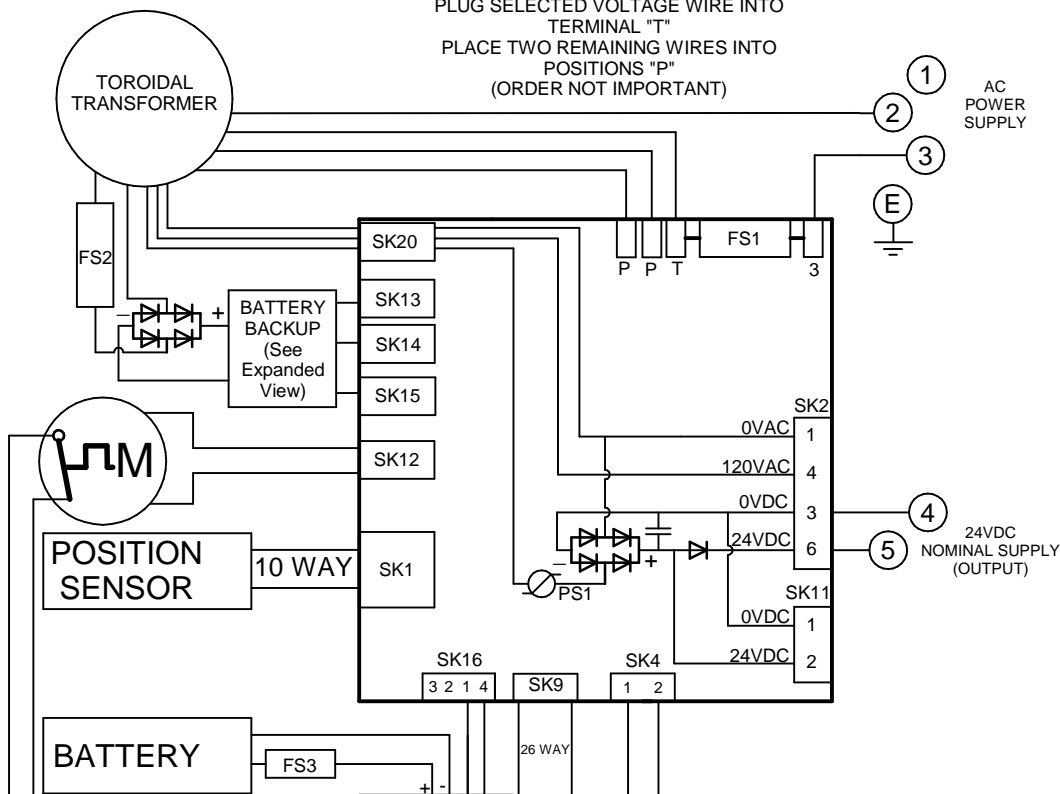

TRANSFORMER VOLTAGE OPTIONS:  
CONNECT CORRESPONDING  
COLOUR TO "T"

TYPE 1		
GREY	100V	FS1 - 5A ANTISURGE
PURPLE	110V	
BROWN	120V	
TYPE 2		
GREY	200V	FS1 - 2.5A ANTISURGE
PURPLE	230V	
BROWN	270V	
TYPE 3		
GREY	380V	FS1 - 2.0A ANTISURGE
PURPLE	400V	
BROWN	415V	
TYPE 4		
GREY	480V	FS1 - 2.0A ANTISURGE
PURPLE	575V	
BROWN	690V	

FS2 - 20A ATO FAST ACTING ALL TYPES

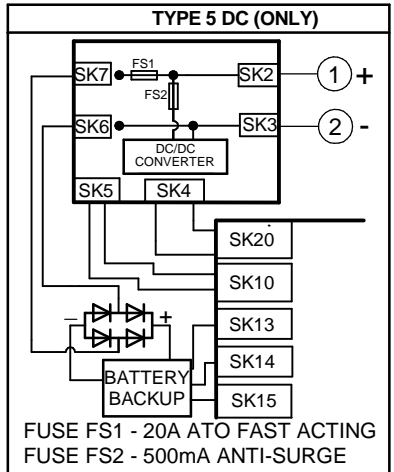

FUSE FS4 - 5A QUICK BLOW

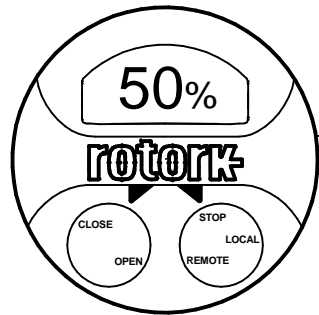
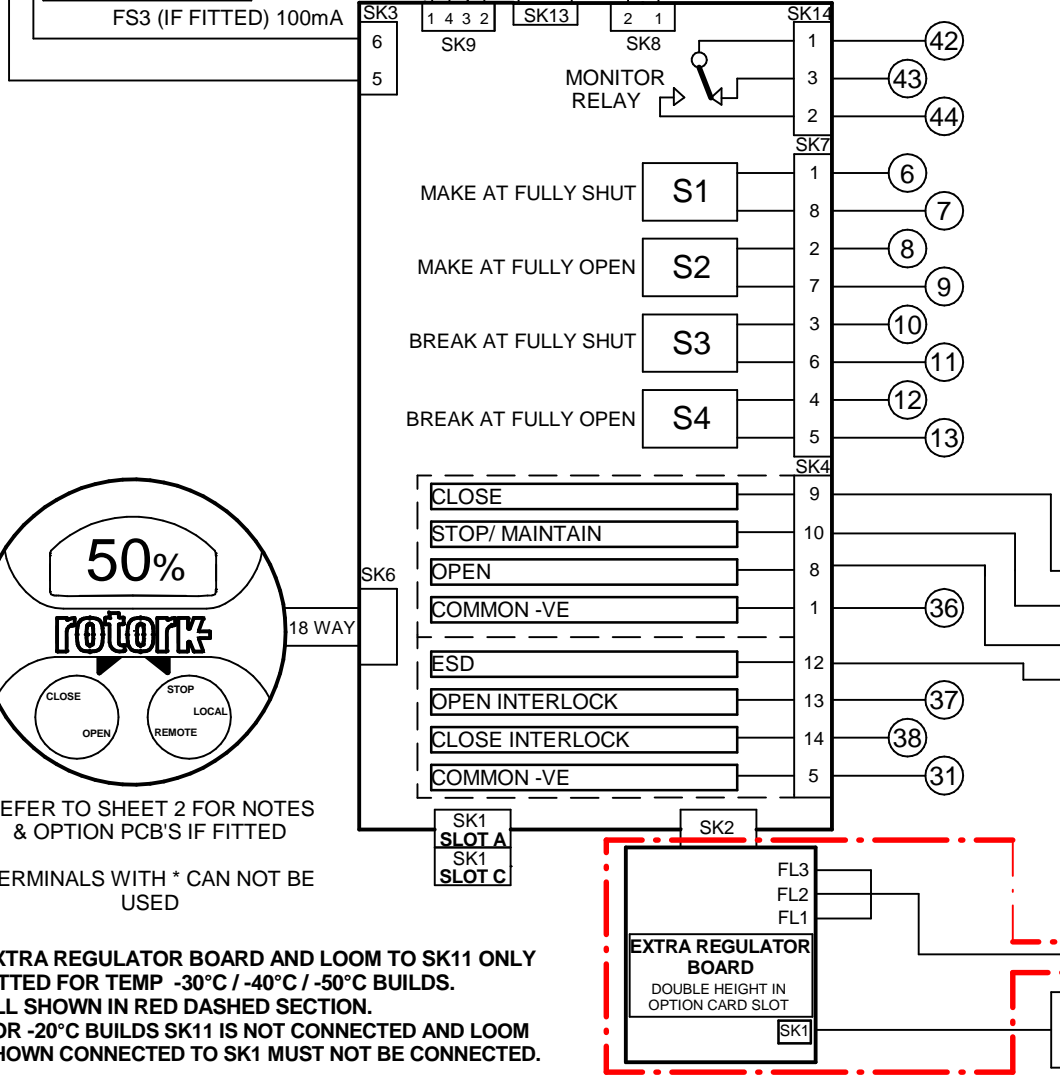
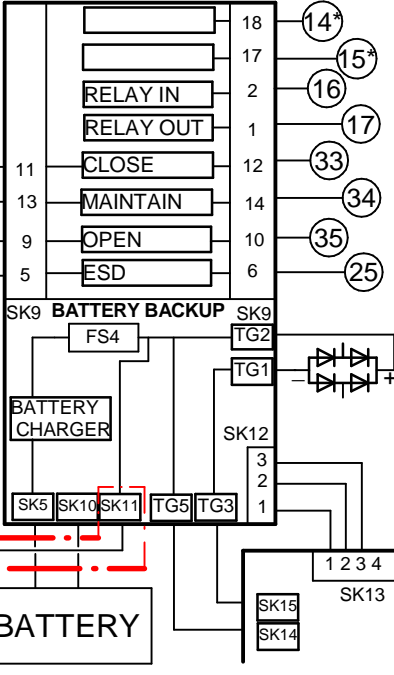

REFER TO SHEET 2 FOR NOTES  
& OPTION PCB'S IF FITTED

TERMINALS WITH \* CAN NOT BE  
USED

EXTRA REGULATOR BOARD AND LOOM TO SK11 ONLY  
FITTED FOR TEMP -30°C / -40°C / -50°C BUILDS.  
ALL SHOWN IN RED DASHED SECTION.  
FOR -20°C BUILDS SK11 IS NOT CONNECTED AND LOOM  
SHOWN CONNECTED TO SK1 MUST NOT BE CONNECTED.

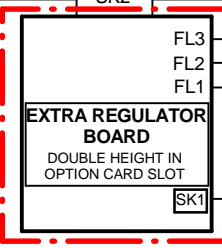

Iss	Date	Chkd	Revision Details	<b>www.rotork.com</b>	IQTm EP BATTERY BACKUP + SINGLE CHANNEL PROFIBUS MODULE + RHS	Circuit Diagram Number <b>470P2006</b>	Issue No <b>2</b>	Sheet <b>1</b> of 2
1	180321	JC1	First issue					
2	111022	SN	Battery Regulator Board Added, Battery Backup View Updated	ROTORK CONTROLS LTD BATH, BA1 3JQ ENGLAND Tel:01225-733200	ROTORK CONTROLS INC ROCHESTER NY 14624, USA Tel:585-247-2304	Drawn by: PJW Date : 180321 Base WD: 470P2000 Job No : - - MI No : - -		

# SLOT A

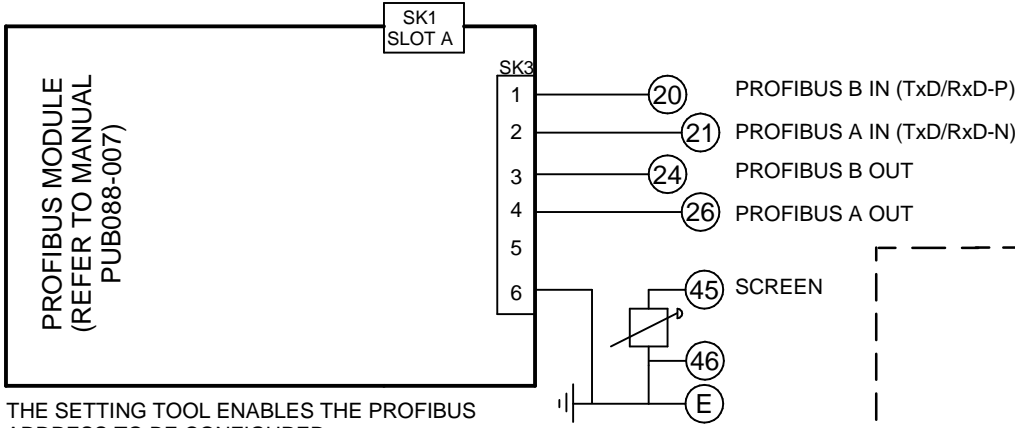

THE SETTING TOOL ENABLES THE PROFIBUS ADDRESS TO BE CONFIGURED.

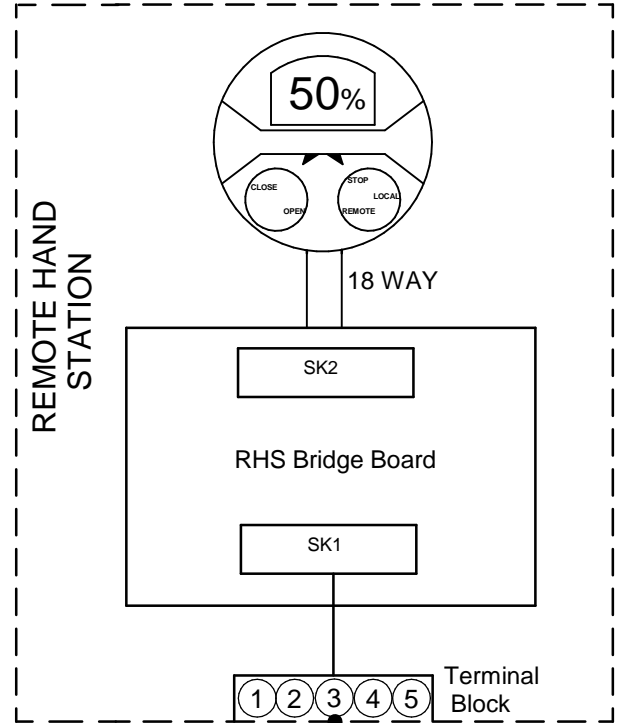

# SLOT C

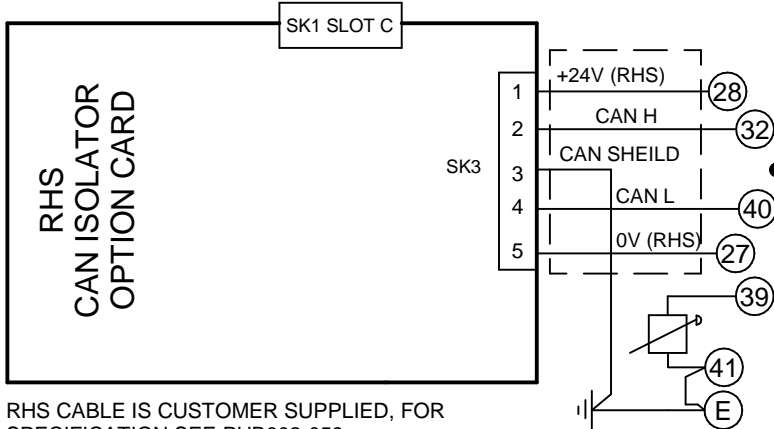

RHS CABLE IS CUSTOMER SUPPLIED, FOR SPECIFICATION SEE PUB002-059, MAXIMUM LENGTH OF CABLE TO BE 100M.

Actuator Terminal Bung No.	RHS Terminal Block No.	Function
28	1	+24V (RHS)
27	2	0V (RHS)
32	3	CAN H
40	4	CAN L
39	5	SHEILD

## NOTES

### 1.FUSES:

- PS1 is a self-resetting fuse.
- Refer to publication PUB002-065 for approved fuses FS1 and FS2.
- Actuator rated voltage specified on nameplate. Voltage tolerance +/-10% applies for rated torque performance; duty cycle is not guaranteed.

### 2.REMOTE CONTROL:

- For typical remote control circuits refer to:
  - RWS indicated or PUB002-041.
- For DC control connect -ve to terminal 36.
- (For negative switch / positive common, refer to RWS indicated).
- Control signal threshold voltages:
  - DC: "on" ≥16Vdc / "off" ≤8Vdc, max 60Vdc.
- Control signal duration to be 100ms minimum.
- Maximum current drawn from remote control signals is:
  - 8mA at 24Vdc
- Supply provided on terminals 4 & 5:
  - Intended for remote control.
  - Max external load 5W at 24Vdc

### 3.INDICATION:

- For typical position, status and alarm indication see PUB002-041.
- "S" contacts are user configurable and are shown in their default setting.
- Refer to PUB002-040 for functions and configuration instructions.
- Monitor Relay indicates actuator availability for remote control (shown "unavailable"). It can be configured to exclude local/remote selection.
- Refer to PUB002-040 for monitored functions and configuration instructions.
- Voltage applied to indication contacts must not exceed 150Vac
- Individual Switch current must not exceed 3.5A inductive, 5A resistive and no more than 8A in total for all 4 contacts.

### 4.BATTERY:

- Battery maintains local and remote "S" contact indication only.
- Refer to installation manual for approved replacement battery types.