

PLUG SELECTED VOLTAGE WIRE INTO  
TERMINAL "T"  
PLACE TWO REMAINING WIRES INTO  
POSITIONS "P"  
(ORDER NOT IMPORTANT)

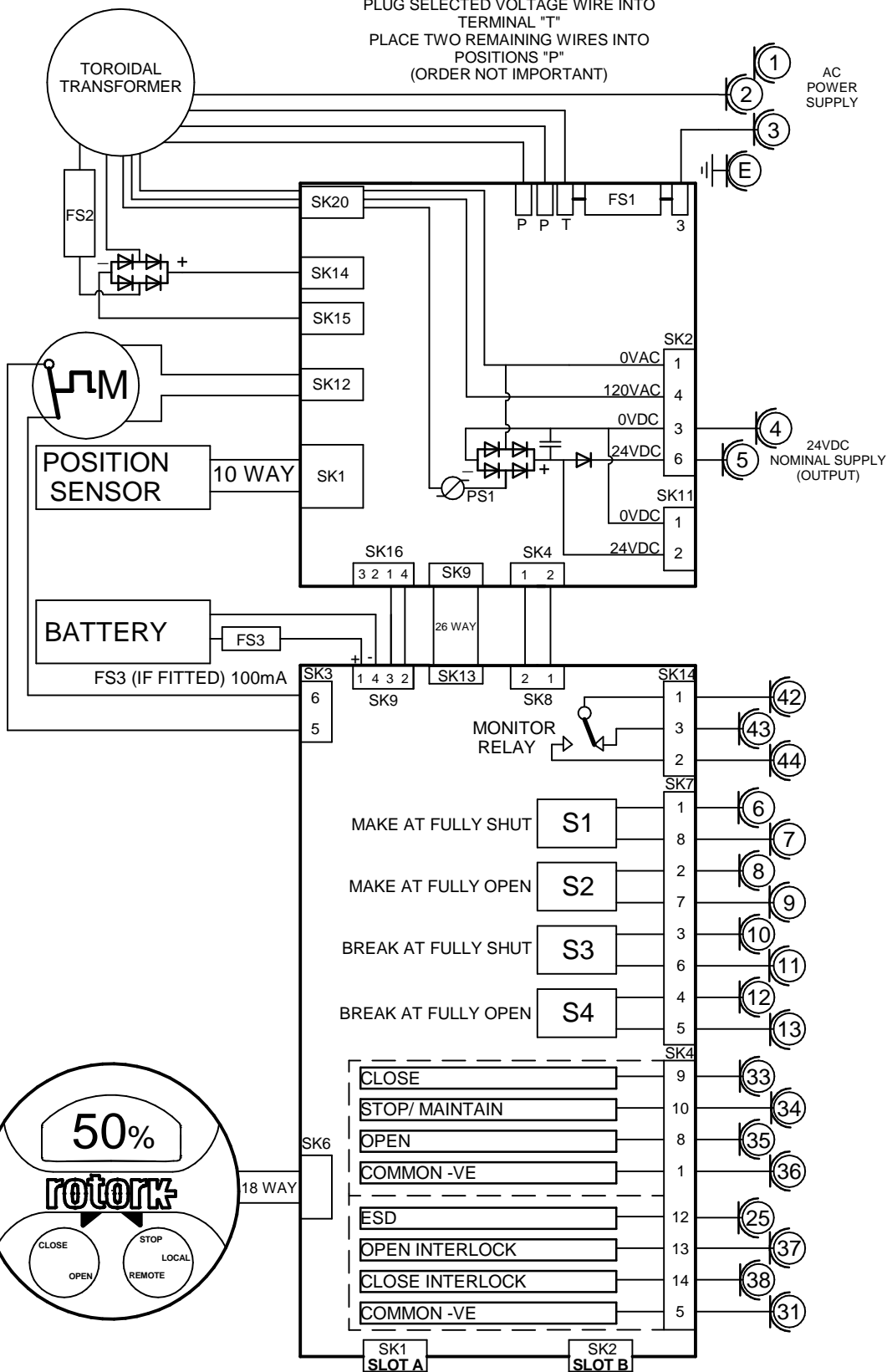

TRANSFORMER VOLTAGE OPTIONS:  
CONNECT CORRESPONDING  
COLOUR TO "T"

TYPE 1		
GREY	100V	FS1 - 5A ANTISURGE
PURPLE	110V	
BROWN	120V	
TYPE 2		
GREY	200V	FS1 - 2.5A ANTISURGE
PURPLE	230V	
BROWN	270V	
TYPE 3		
GREY	380V	FS1 - 2.0A ANTISURGE
PURPLE	400V	
BROWN	415V	
TYPE 4		
GREY	480V	FS1 - 2.0A ANTISURGE
PURPLE	575V	
BROWN	690V	

FS2 - 20A ATO FAST ACTING ALL TYPES

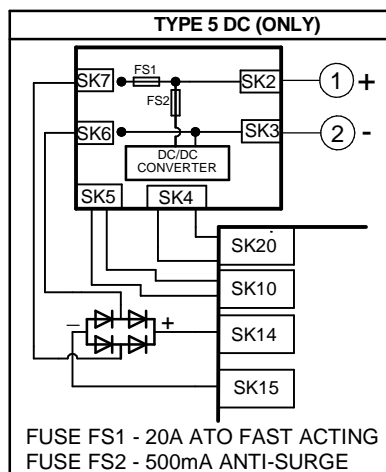

REFER TO SHEET 2 FOR NOTES  
& OPTION PCB'S IF FITTED

PLUG & SOCKET CONNECTION

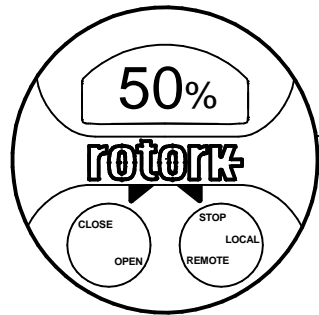

Iss	Date	Chkd	Revision Details
1	150222	JC1	FIRST ISSUE

[www.rotork.com](http://www.rotork.com)

ROTORK CONTROLS LTD BATH, BA1 3JQ ENGLAND Tel:01225-733200	ROTORK CONTROLS INC ROCHESTER NY 14624, USA Tel:585-247-2304
---	---

IQT + DUAL CHANNEL PROFIBUS MODULE + PLUG & SOCKET		Circuit Diagram Number		Issue No	Sheet
		<b>300P3002</b>		<b>1</b>	<b>1</b>
B1	C1	B2	C2		

Drawn by: PJW  
Date : 150222  
Base WD: 300P3002  
Job No : --  
MI No : --

# SLOT A

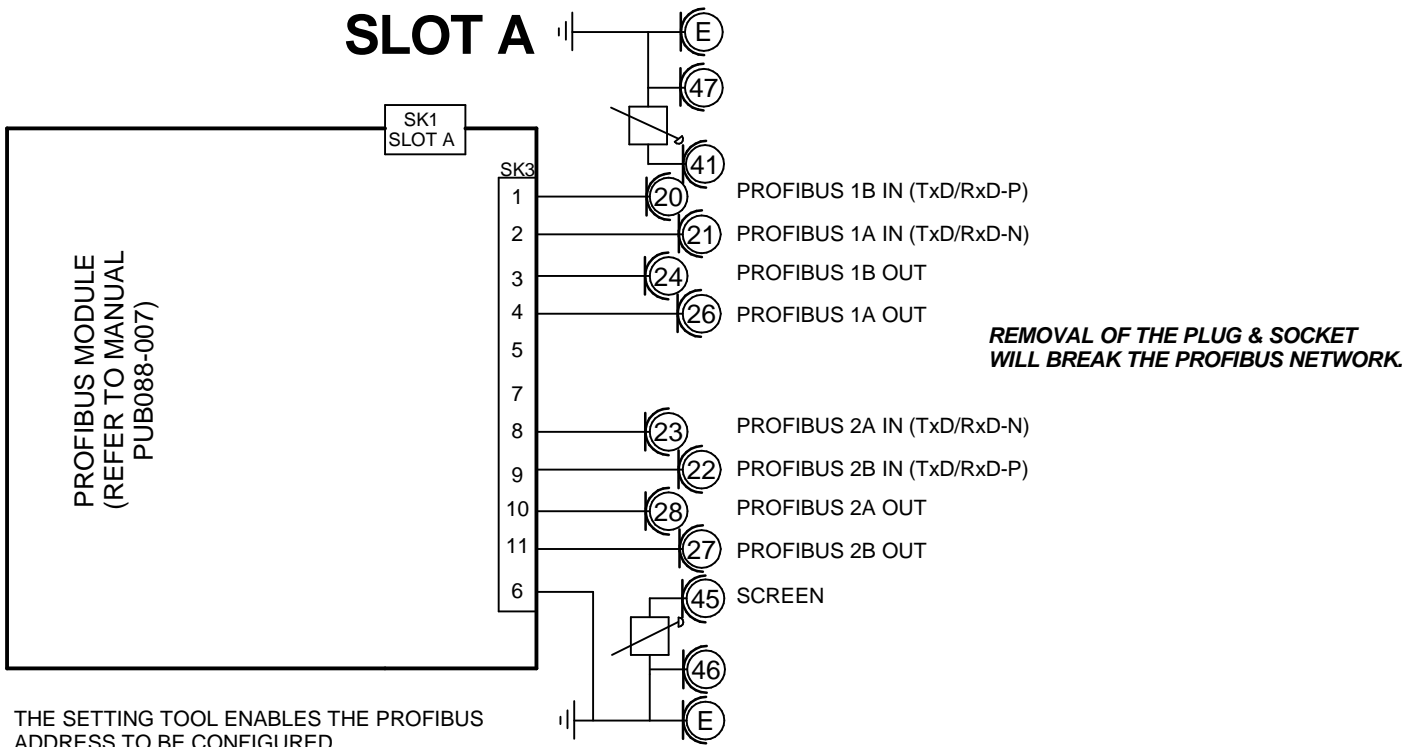

THE SETTING TOOL ENABLES THE PROFIBUS ADDRESS TO BE CONFIGURED.

## NOTES

### 1.FUSES:

- PS1 is a self-resetting fuse.
- Refer to publication PUB002-065 for approved fuses FS1 and FS2.
- Actuator rated voltage specified on nameplate. Voltage tolerance +/-10% applies for rated torque performance; duty cycle is not guaranteed.

### 2.REMOTE CONTROL:

- For typical remote control circuits refer to:
  - RWS indicated or PUB002-041.
- For DC and AC control, connect -ve/0V to terminal 36.
- (For negative switch / positive common, refer to RWS indicated).
- Control signal threshold voltages:
  - DC: "on"  $\geq 16Vdc$  / "off"  $\leq 8Vdc$ , max 60Vdc.
  - AC: "on"  $\geq 60Vac$  / "off"  $\leq 40Vac$ , max 120Vac.
- Control signal duration to be 300ms minimum.
- Maximum current drawn from remote control signals is:
  - 8mA at 24Vdc or 12mA at 120Vac.
- Supply provided on terminals 4 & 5:
  - Intended for remote control.
  - Max external load 5W at 24Vdc / 5VA at 120Vac

### 3.INDICATION:

- For typical position, status and alarm indication see PUB002-041.
- "S" contacts are user configurable and are shown in their default setting.
- Refer to PUB002-040 for functions and configuration instructions.
- Monitor Relay indicates actuator availability for remote control (shown "unavailable"). It can be configured to exclude local/remote selection.
- Refer to PUB002-040 for monitored functions and configuration instructions.
- Voltage applied to indication contacts must not exceed 150Vac
- Individual Switch current must not exceed 3.5A inductive, 5A resistive and no more than 8A in total for all 4 contacts.

### 4.BATTERY:

- Battery maintains local and remote "S" contact indication only.
- Refer to installation manual for approved replacement battery types.