

E0300020

**PLUG-AND-SOCKET CONNECTOR LAYOUT**

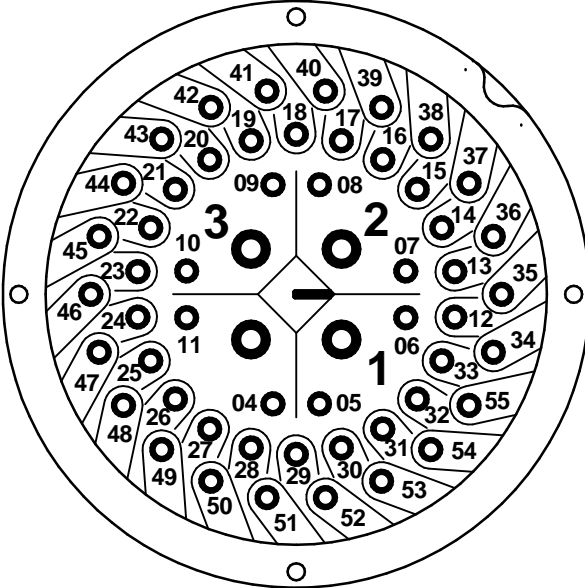

**LEGENDS:**

- M1** ELECTRIC MOTOR
- RL1** RELAY OUTPUT No1 (SETTABLE)
- RL2** RELAY OUTPUT No2 (SETTABLE)
- RL4** RELAY OUTPUT No4 (SETTABLE)
- RL5** RELAY OUTPUT No5 (SETTABLE)
- RL6** RELAY OUTPUT No6 (SETTABLE)
- RL7** RELAY OUTPUT No7 (SETTABLE)
- CS** CUSTOMER SUPPLY
- POSITIONER** POSITIONER IN/OUT ANALOG SIGNAL
- POSITIONER.LP** POSITIONER IN/OUT ANALOG SIGNAL. LOOP POWER
- MONIT.** MONITOR RELAY
- FIELDBUS** FIELDBUS CARD
- REMOTE** REMOTE INPUT CARDS
- ACTS** AUXILIARY CLOSE TORQUE SWITCH
- AOTS** AUXILIARY OPEN TORQUE SWITCH
- ACLS** AUXILIARY CLOSE LIMIT SWITCH
- AOLS** AUXILIARY OPEN LIMIT SWITCH
- CPT** CURRENT POSITION TRANSMITTER
- CPT.LP** CURRENT POSITION TRANSMITTER, LOOP POWER
- CTS** CLOSE TORQUE SWITCH
- OTS** OPEN TORQUE SWITCH
- CLS** CLOSE LIMIT SWITCH
- OLS** OPEN LIMIT SWITCH
- TRM** THERMAL PROTECTION DEVICE (MOTOR WIND.)
- HT** ANTI-CONDENSATION HEATER

- BLK** BLINKER SWITCH
- POT** POTENTIOMETER (VALVE POSITION SIGNAL)

**NOTES:**

1. THE TERMINAL PLAN SHOWS THE QUARTER-TURN ELECTRIC ACTUATOR IN INTERMEDIATE POSITION, ACTUATOR CLOSURES VALVE CLOCKWISE.
2. SEE ACTUATOR USER MANUAL AND DATASHEETS FOR TECHNICAL DATA, PARAMETERS AND DESCRIPTION OF THE ACTUATOR ELECTRIC AND ELECTRONIC EQUIPMENT.
3. THE USER MUST FIT A OVERLOAD RELAY. THE RELAY MUST BE SIZED ACCORDING TO THE OVERCURRENT PROT. DEVICE SETTING VALUE FOR THE MOTOR.
4. REFER TO THE MOTOR DATA SHEET FOR THIS VALUE. THE OVERLOAD RELAY MUST BE SIZED TO ENSURE THAT IT TRIPS WITHIN 10 SECONDS IN A FAULT CONDITION.
5. THE USER MUST COMPLETE A RISK ASSESSMENT AND IMPLEMENT WHATEVER MEASURES ARE REQUIRED TO ENSURE THAT THE RESULTANT SYSTEM COMPLIES WITH ALL APPLICABLE LEGISLATION.

PARAMETER	VALUE	DESCRIPTION
TYPE	E	QUARTER-TURN ELECTRIC ACTUATOR, WITH ATRONIK (MECHANICAL SWITCH MECH.)
MAIN POWER SUPPLY	0	A.C. THREE PHASE
EXTRA CARD No 1	3	MODBUS RTU
EXTRA CARD No2	0	NO (WITHOUT)
MOTOR STARTER	0	REVERSIBLE CONTACTORS (STANDARD)
CUSTOMER SUPPLY & BLUETOOTH	0	24VDC±20% AT MAX.POW.OUTPUT 5W
BACKUP SUPPLY & HEATER	2	NO BACKUP SUPPLY, HEATER INCLUDED
EXTRA SWITCH	0	STANDARD - WITHOUT

ISSUE	DESCRIPTION	DATE	ISSUE	DESCRIPTION	DATE
1	FIRST PRODUCTION RELEASE	20-08-21			

SHEET 1/2	DATE	SIGN.	TERMINAL PLAN
MADE BY	8/20/2021	MAHI	WD CKQA ATK, MSM, 3PH, MB1, NOEX2, C TOR, CS24, NOBK-HT, NOEXT
CHECKED	8/20/2021	DAB	
APPROVED	8/20/2021	DAB	

<b>CK</b> range	FORMAT	DRAWING N°
	A4	E0300020-1

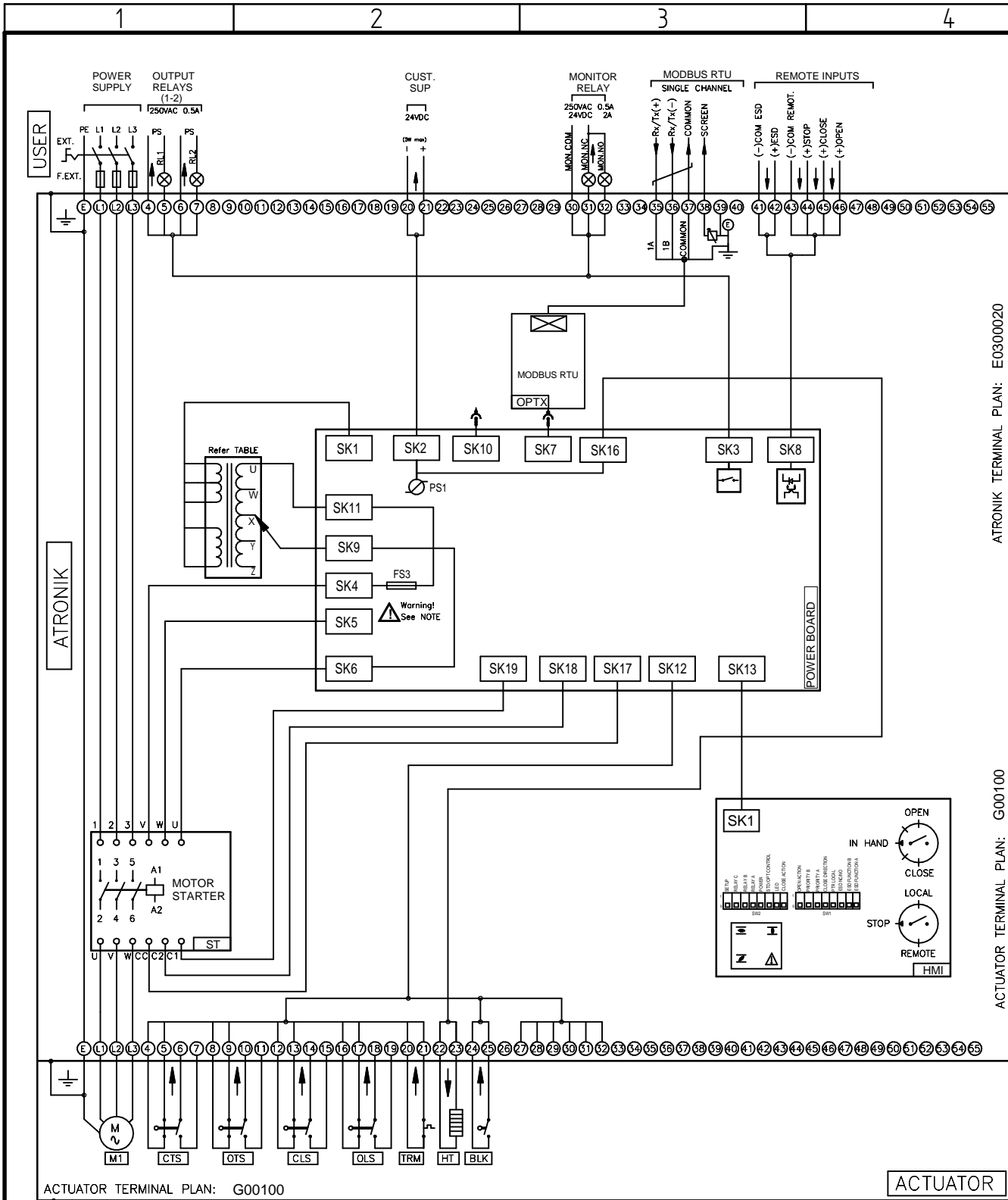

ACTUATOR TERMINAL PLAN: G00100

ACTUATOR

**WARNING:** REFER TO SAFE USE AND INSTALLATION MANUAL FOR APPROVED FUSES.  
 FS3: SIBA, 70-065-65 1A, 500V, 6.3mmx32mm

**TRANSFORMER TAPPING OPTIONS**

PRIMARY TAP NOMINAL VOLTAGE (VAC 50/60 Hz)			
TAP	TYPE 1	TYPE 2	TYPE 3
W	110/115	380	500
X	208	400/415	575
Y	220	440	600
Z	230/240	460/480	690

- THE TERMINAL PLAN SHOWS THE QUARTER-TURN ELECTRIC ACTUATOR IN INTERMEDIATE POSITION, ACTUATOR CLOSES VALVE CLOCKWISE.
- REFER TO SAFE USE AND INSTALLATION MANUAL AND DATASHEETS FOR TECH. DATA, PARAMETERS AND DESCRIPTION OF THE ACTUATOR ELECTRIC AND ELECTRONIC EQUIPMENT.
- THE USER MUST CONDUCT A RISK ASSESSMENT, AND IMPLEMENT WHATEVER EXTRA SAFETY MEASURES ARE REQUIRED, TO ENSURE THAT THE RESULTANT SYSTEM COMPLIES WITH THE LOW VOLTAGE DIRECTIVE, AND ANY OTHER LEGISLATION IN FORCE AT THE INSTALLATION SITE.
- REFER INSTALLATION MANUAL TO CONFIGURE SW1 AND SW2

ISSUE	DESCRIPTION	DATE	ISSUE	DESCRIPTION	DATE
1	FIRST PRODUCTION RELEASE	20-08-21			

SHEET 2/2	DATE	SIGN.	WIRING DRAWING WD CKQA ATK, MSM, 3PH, MB1, NOEX2, CTOR, CS24, NOBK-HT, NOEXT	This drawing and the information it contains are property of Rotork Controls Limited, and they will not be reproduced or disclosed, in whole or in part, without the prior written consent of Rotork.		
MADE BY	8/20/2021	MAHI			FORMAT	DRAWING N°
CHECKED	8/20/2021	DAB			A4	E0300020-1
APPROVED	8/20/2021	DAB				

ATRONIK TERMINAL PLAN: E0300020  
 ACTUATOR TERMINAL PLAN: G00100  
 F