

PLUG SELECTED VOLTAGE WIRE INTO
TERMINAL "T"
PLACE TWO REMAINING WIRES INTO
POSITIONS "P"
(ORDER NOT IMPORTANT)

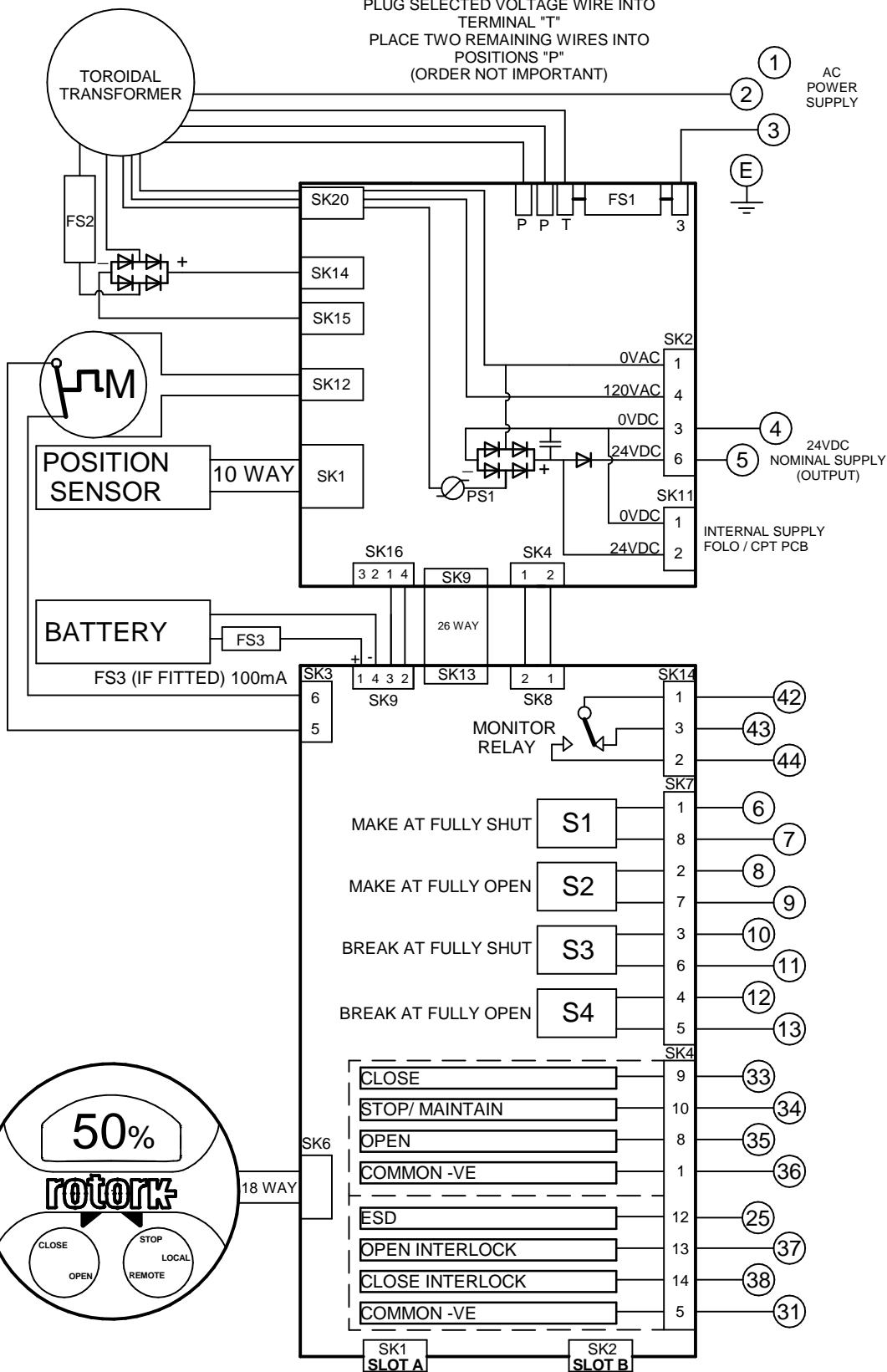

TRANSFORMER VOLTAGE OPTIONS:
CONNECT CORRESPONDING
COLOUR TO "T"

| TYPE 1 | | |
|--------|------|-------------------------|
| GREY | 100V | FS1 - 5A ANTISURGE |
| PURPLE | 110V | |
| BROWN | 120V | |
| TYPE 2 | | |
| GREY | 200V | FS1 - 2.5A ANTISURGE |
| PURPLE | 230V | |
| BROWN | 270V | |
| TYPE 3 | | |
| GREY | 380V | FS1 - 2.0A ANTISURGE |
| PURPLE | 400V | |
| BROWN | 415V | |
| TYPE 4 | | |
| GREY | 480V | FS1 - 2.0A ANTISURGE |
| PURPLE | 575V | |
| BROWN | 690V | |

FS2 - 20A ATO FAST ACTING ALL TYPES

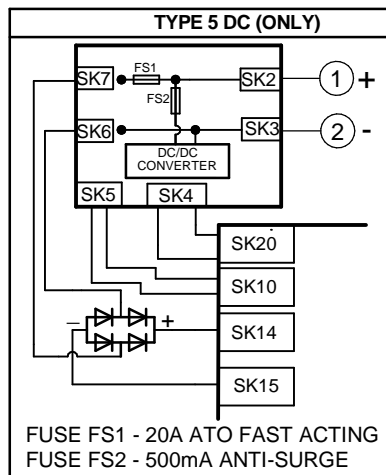

REFER TO SHEET 2 FOR NOTES
& OPTION PCB'S IF FITTED

| Iss | Date | Chkd | Revision Details |
|-----|--------|------|------------------|
| 1 | 240523 | JC1 | First Issue. |

www.rotork.com

ROTORK CONTROLS LTD
BATH, BA1 3JQ
ENGLAND
Tel:01225-733200

ROTORK CONTROLS INC
ROCHESTER
NY 14624, USA
Tel:585-247-2304

IQT + DUAL CHANNEL MODBUS MODULE +
FOLOMATIC + CPT

Drawn by: PJW
Date : 240523
Base WD: 303M3000
Job No : --
MI No : --

| Circuit Diagram Number | | Issue No | Sheet |
|------------------------|----|----------|----------|
| 303M3000 | | 1 | 1 |
| B1 | C1 | B2 | C2 |

SLOT A

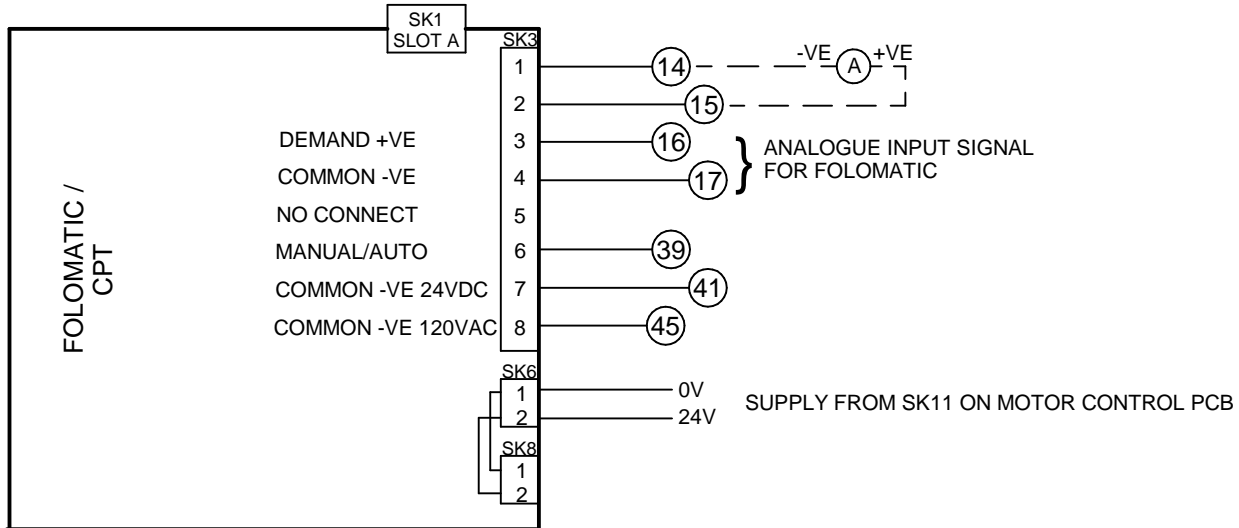

FOR MANUAL/AUTO CONNECTIONS AND
DETAILS OF FOLOMATIC/CPT FUNCTIONS
REFER TO ROTORK PUBLICATION PUB002-041

SLOT B

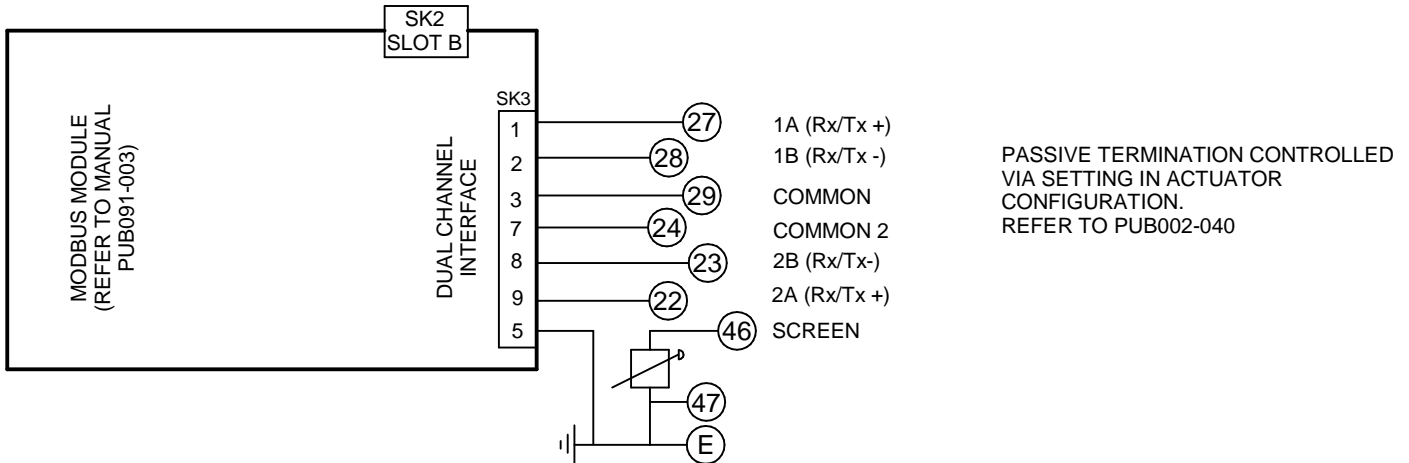

MODBUS RS485 SIGNAL LINES REQUIRE EXTERNAL ACTIVE
BIASING TO BE PROVIDED AT ONE LOCATION FOR THE WHOLE
BUS SEGMENT. REFER TO PUB091-004.

NOTES

1.FUSES:

- PS1 is a self-resetting fuse.
- Refer to publication PUB002-065 for approved fuses FS1 and FS2.
- Actuator rated voltage specified on nameplate. Voltage tolerance +/-10%, applies for rated torque performance; duty cycle is not guaranteed.

2.REMOTE CONTROL:

- For typical remote control circuits refer to:
 - RWS indicated or PUB002-041.
- For DC and AC control, connect -ve/0V to terminal 36.
- (For negative switch / positive common, refer to RWS indicated).
- Control signal threshold voltages:
 - DC: "on" ≥16Vdc / "off" ≤8Vdc, max 60Vdc.
 - AC: "on" ≥60Vac / "off" ≤40Vac, max 120Vac.
- Control signal duration to be 300ms minimum.
- Maximum current drawn from remote control signals is:
 - 8mA at 24Vdc or 12mA at 120Vac.
- Supply provided on terminals 4 & 5:
 - Intended for remote control.
 - Max external load 5W at 24Vdc / 5VA at 120Vac

3.INDICATION:

- For typical position, status and alarm indication see PUB002-041.
- “S” contacts are user configurable and are shown in their default setting.
- Refer to PUB002-040 for functions and configuration instructions.
- Monitor Relay indicates actuator availability for remote control (shown “unavailable”). It can be configured to exclude local/remote selection.
- Refer to PUB002-040 for monitored functions and configuration instructions.
- Voltage applied to indication contacts must not exceed 150Vac
- Individual Switch current must not exceed 3.5A inductive, 5A resistive and no more than 8A in total for all 4 contacts.

4.BATTERY:

- Battery maintains local and remote “S” contact indication only.
- Refer to installation manual for approved replacement battery types.