

FOR TYPICAL REMOTE CONTROL DETAILS, SEE DOCUMENT **RWS122**

| TRANSFORMER TAPPING OPTIONS | |
|-----------------------------|-----------------|
| Tap | Nominal 50/60Hz |
| TYPE 1 | |
| W | 220/230 |
| X | 380/400 |
| Y | 400,415/420 |
| Z | 440/460 |
| FUSE FS 1=250mA ANTI-SURGE | |
| TYPE 2 | |
| W | 346/380 |
| X | 480/500 |
| Y | 240/240 |
| Z | 550/575 |
| FUSE FS 1=250mA ANTI-SURGE | |
| TYPE 3 | |
| X | 660/660-690 |
| Y | 690/- |
| FUSE FS 1=150mA ANTI-SURGE | |

REFER TO SHEET 2 FOR NOTES & OPTION PCB'S IF FITTED

PLUG & SOCKET CONNECTION

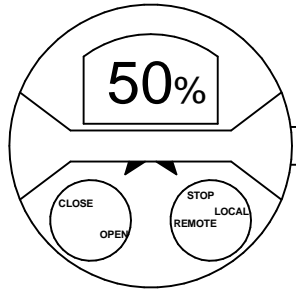
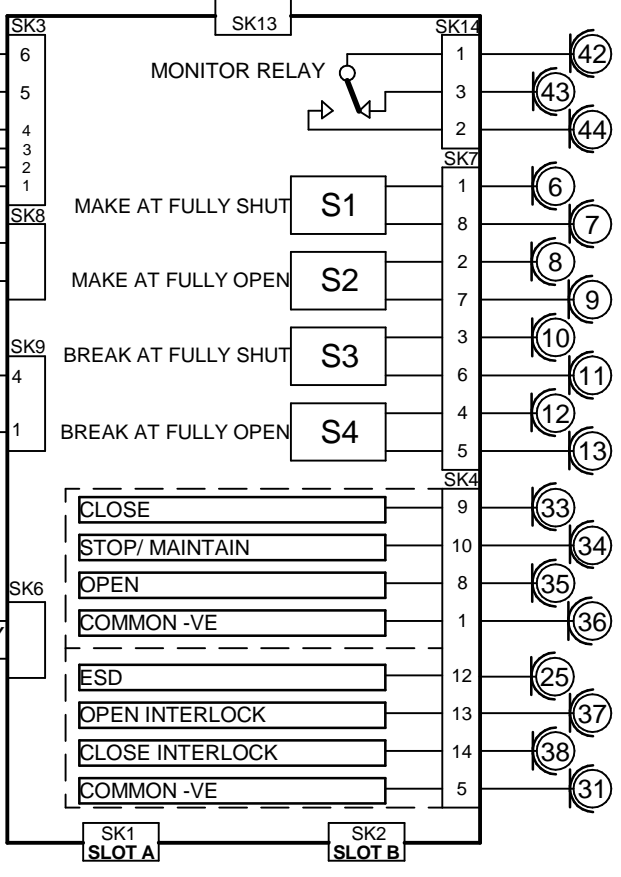
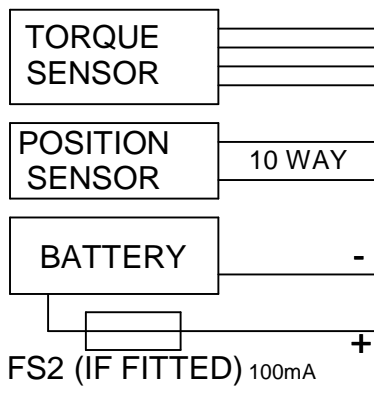

| Iss | Date | Chkd | Revision Details |
|-----|--------|------|------------------|
| 1 | 210603 | JC1 | First Issue. |

www.rotork.com

| | |
|---|---|
| ROTORK CONTROLS LTD BATH, BA1 3JQ ENGLAND Tel:01225-733200 | ROTORK CONTROLS INC ROCHESTER NY 14624, USA Tel:585-247-2304 |
|---|---|

| | | | | | |
|--|----|---|----|----------------------|---------------------------|
| IQ + SINGLE CHANNEL MODBUS + FOLOMATIC & CPT + PLUG & SOCKET | | Circuit Diagram Number 103M2002 | | Issue No 1 | Sheet 1 of 2 |
| B1 | C1 | B2 | C2 | | |

SLOT A

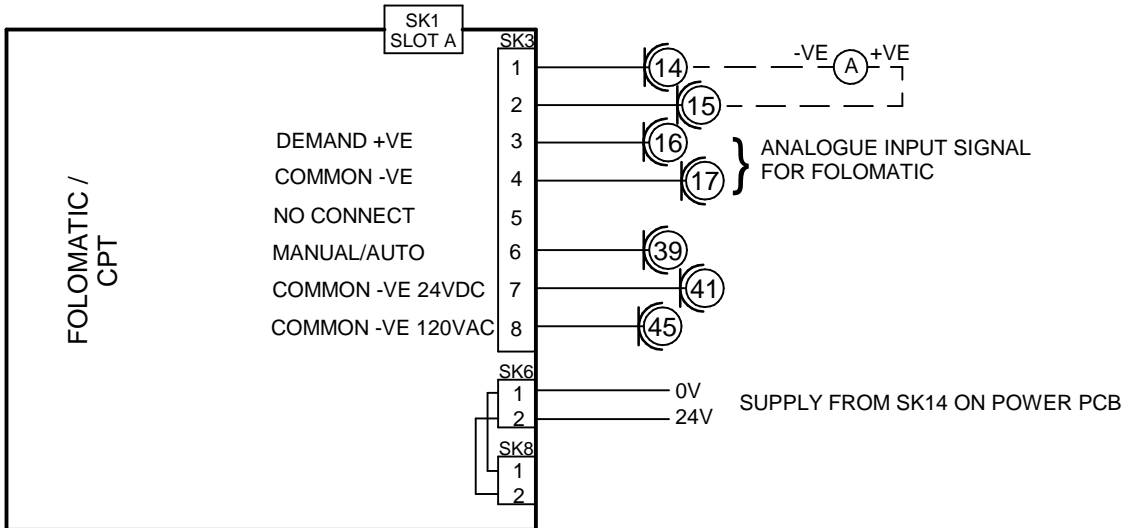

FOR MANUAL/AUTO CONNECTIONS AND DETAILS OF FOLOMATIC/CPT FUNCTIONS REFER TO ROTORK PUBLICATION PUB002-041

SLOT B

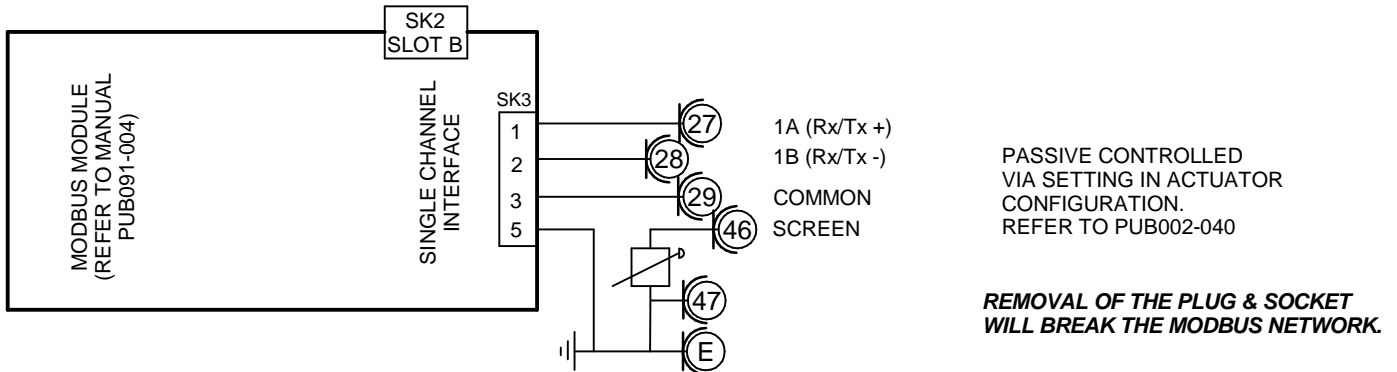

MODBUS RS485 SIGNAL LINES REQUIRE EXTERNAL ACTIVE BIASING TO BE PROVIDED AT ONE LOCATION FOR THE WHOLE BUS SEGMENT. REFER TO PUB091-004

NOTES

1.FUSES:

- PS1 is a self-resetting fuse.
- Refer to publication PUB002-039 for approved fuses FS1 and FS2.
- Actuator rated voltage specified on nameplate. Voltage tolerance +/-10%, applies for rated torque performance; duty cycle is not guaranteed.

2.REMOTE CONTROL:

- For typical remote control circuits refer to:
 - RWS indicated or PUB002-041.
- For DC and AC control, connect -ve/0V to terminal 36.
- (For negative switch / positive common, refer to RWS indicated).
- Control signal threshold voltages:
 - DC: "on" ≥16Vdc / "off" ≤8Vdc, max 60Vdc.
 - AC: "on" ≥60Vac / "off" ≤40Vac, max 120Vac.
- Control signal duration to be 300ms minimum.
- Maximum current drawn from remote control signals is:
 - 8mA at 24Vdc or 12mA at 120Vac.
- Supply provided on terminals 4 & 5:
 - Intended for remote control.
 - Max external load 5W at 24Vdc / 5VA at 120Vac

3.INDICATION:

- For typical position, status and alarm indication see PUB002-041.
- “S” contacts are user configurable and are shown in their default setting.
- Refer to PUB002-040 for functions and configuration instructions.
- Monitor Relay indicates actuator availability for remote control (shown “unavailable”). It can be configured to exclude local/remote selection.
- Refer to PUB002-040 for monitored functions and configuration instructions.
- Voltage applied to indication contacts must not exceed 150Vac
- Individual Switch current must not exceed 3.5A inductive, 5A resistive and no more than 8A in total for all 4 contacts.

4.BATTERY:

- Battery maintains local and remote “S” contact indication only.
- Refer to installation manual for approved replacement battery types.

See Sheet 1 for all Revision details/information