

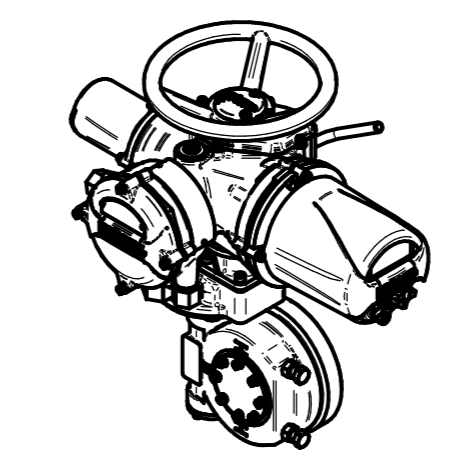

H  
G  
F  
E  
D  
C  
B  
A

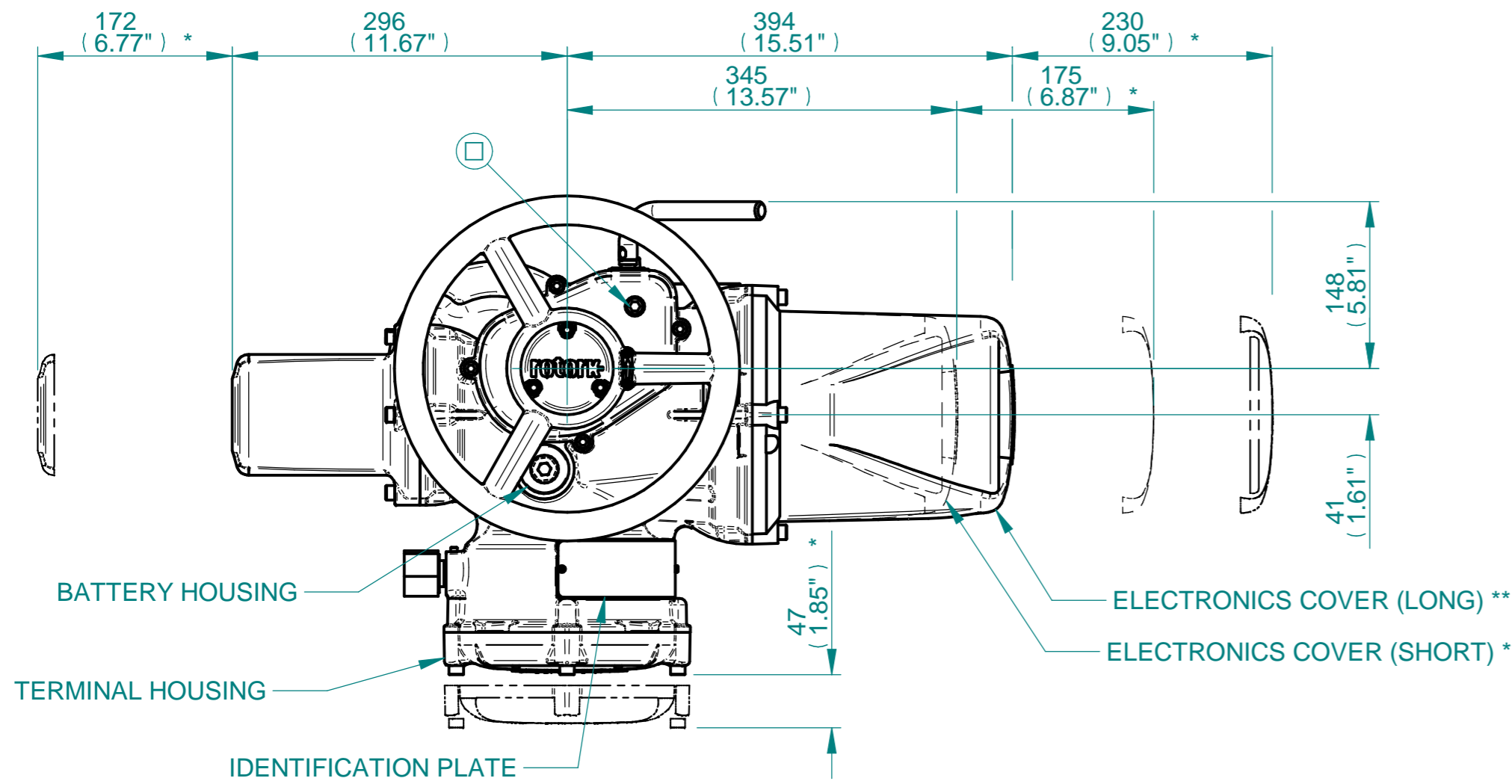

ISOMETRIC VIEW (SCALE 1:12)

**NOTES:**  
 :DIMENSIONS WITH "\*" INDICATE COVER REMOVAL ALLOWANCE  
 :ELECTRONICS COVER OPTION "\*" WILL VARY DEPENDING ON CONFIGURATION  
 :NETT WEIGHT = 69kg/153lbs  
 :  = OIL FILLER/DRAIN PLUG  
 :THE INTERFACE PROVIDED FOR MOUNTING THE ACTUATOR OR SECOND STAGE GEARBOX ONTO THE VALVE SHOULD CONFORM TO GOOD ENGINEERING PRACTICES, ENSURING ADEQUATELY TOLERANCED LIMITS FOR PARALLELISM, PERPENDICULARITY AND CONCENTRICITY.  
 :ROTORC CANNOT BE HELD LIABLE FOR DAMAGE TO OUR EQUIPMENT CAUSED BY EXCESSIVE LOADING FROM COVER TUBES. (SEE ALSO PUB000-124)

**CONDUIT ENTRIES**

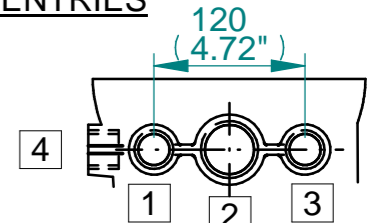

	Hole 1	Hole 2	Hole 3	Hole 4
Size	As Required	As Required	As Required	As Required
Plugged	As Required	As Required	As Required	As Required
Gland	As Required	As Required	As Required	As Required

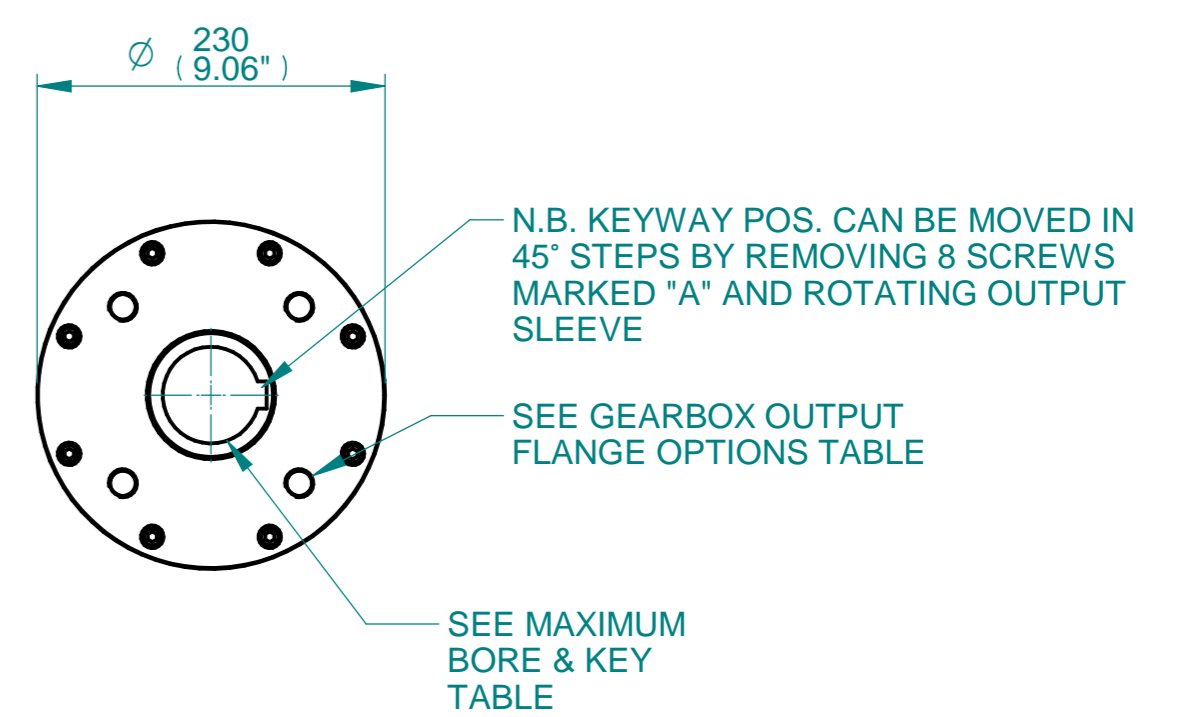
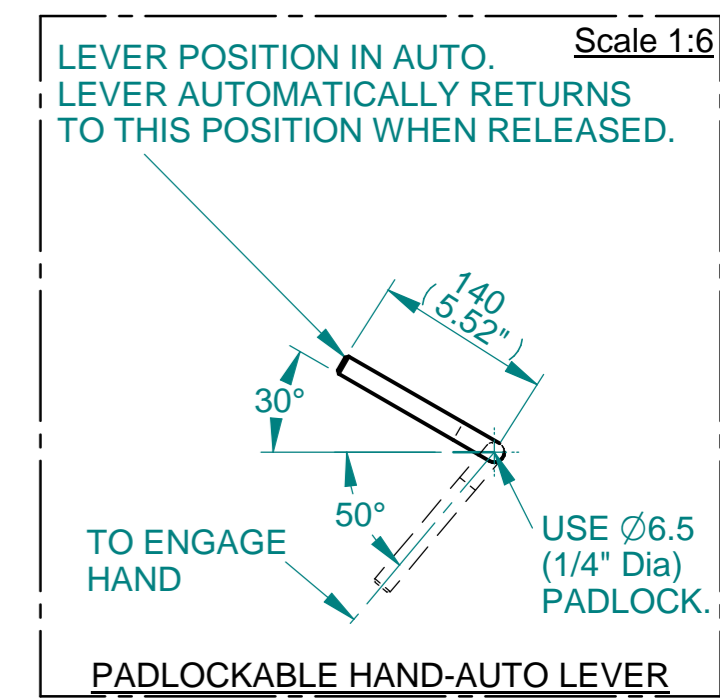
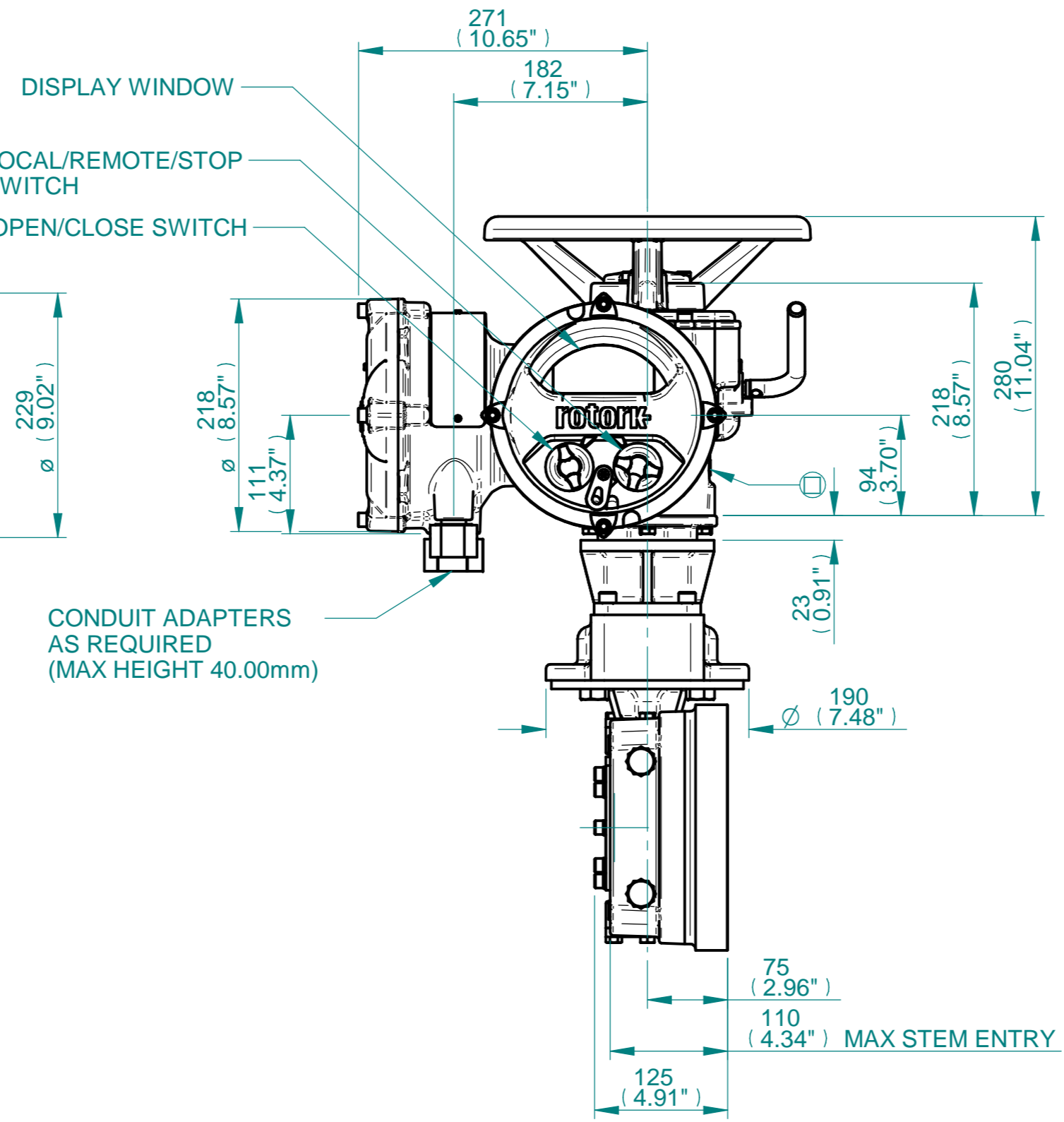
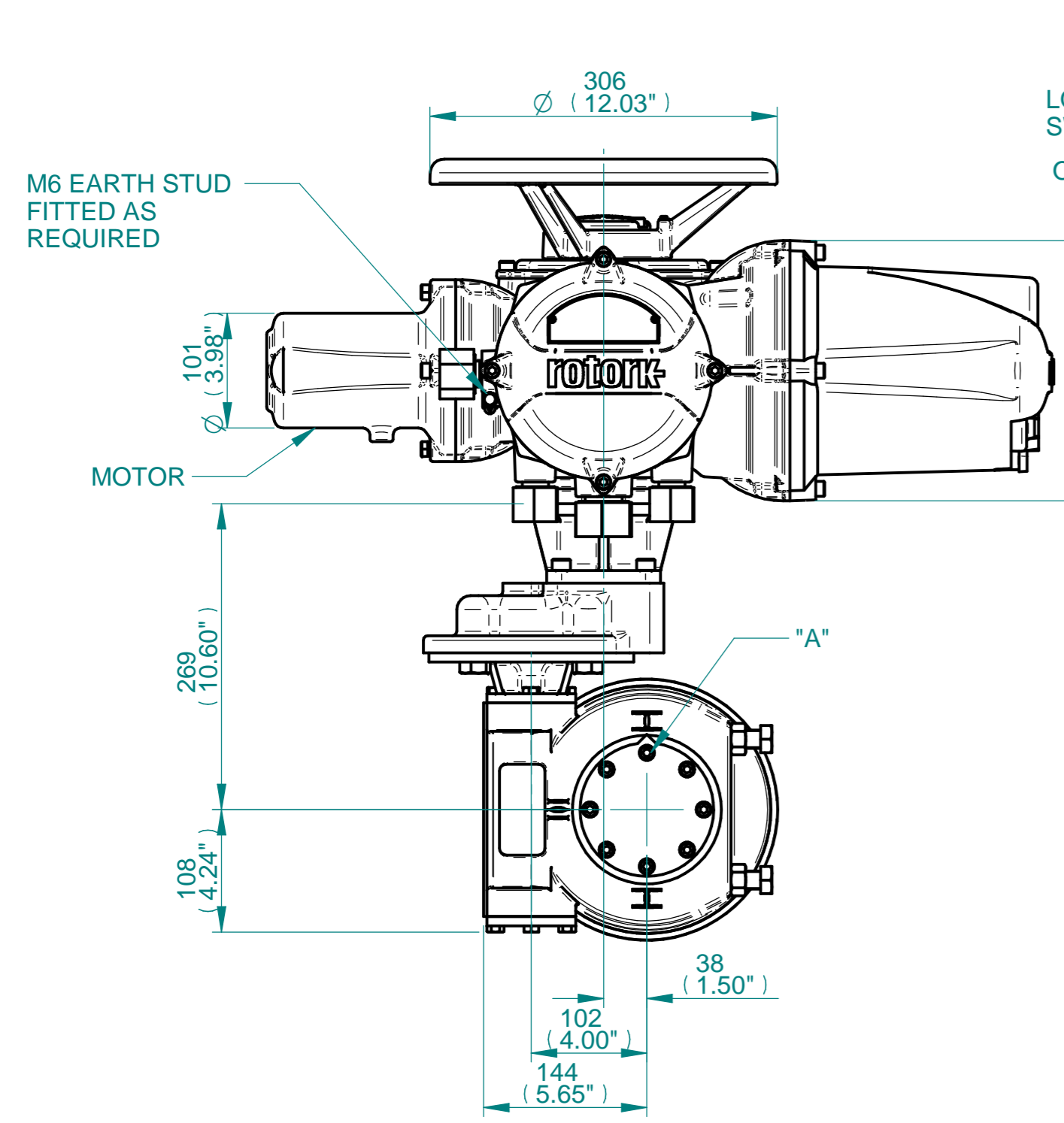

3D Models are available in various formats under the same drawing number

**rotork**  
 www.rotork.com  
 Rotork Controls Limited  
 Bath, BA1 3JQ, England.  
 Telephone 01225-733200

Actuator Size: IQ10/12/18 IW4RL/MOW4RL		Gearbox output flange options								Maximum Bore & Key			
Title	IQ10/12/18, TOP HANDWHEEL, IW4RL / MOW4RL, F/FA16, Ratios 80 - 280:1 Installation Details	Designation	F16	-	-	-	FA16	-	-	-	Key form	Ø Bore	Key size
Drawn	DJW	No. Holes	4	-	-	-	4	-	-	-	Rectangle (BS4235)	64	18 X 11
Checked	NJC	Hole size	M20	-	-	-	3/4" UNC	-	-	-	Rectangle (ANSI B17.1)	2-1/2"	5/8 X 7/16"
Date	21-AUG-23	PCD	165	-	-	-	6.5"	-	-	-	Square (ANSI B17.1)	2-1/4"	1/2" SQ
Ref	SALES	Project Ref	QUOTATION										

Issue	Description
1	FIRST ISSUE

Scale: 1:5

THIRD ANGLE PROJECTION

Drawing Number	Issue No	Sheet No
I11THWIW4RLENH	1	1 of 1

1 2 3 4 5 6 7 8 9 10 11 12