

A0000029X

**PLUG-AND-SOCKET CONNECTOR LAYOUT**

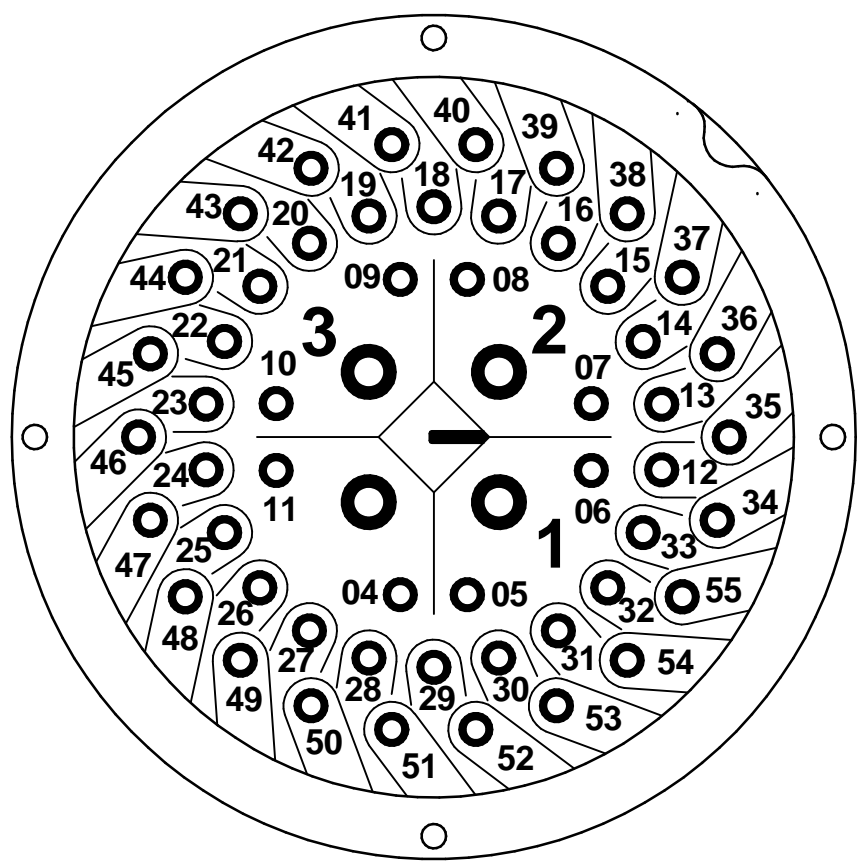

**LEGENDS:**

- M1** ELECTRIC MOTOR
- RL1** RELAY OUTPUT No1 (SETTABLE)
- RL2** RELAY OUTPUT No2 (SETTABLE)
- RL4** RELAY OUTPUT No4 (SETTABLE)
- RL5** RELAY OUTPUT No5 (SETTABLE)
- RL6** RELAY OUTPUT No6 (SETTABLE)
- RL7** RELAY OUTPUT No7 (SETTABLE)
- CS** CUSTOMER SUPPLY
- POSITIONER** POSITIONER IN/OUT ANALOG SIGNAL
- POSITIONER.LP** POSITIONER IN/OUT ANALOG SIGNAL LOOP POWER
- MONIT.** MONITOR RELAY
- FIELDBUS** FIELDBUS CARD
- REMOTE** REMOTE INPUT CARDS
- ACTS** AUXILIARY CLOSE TORQUE SWITCH
- AOTS** AUXILIARY OPEN TORQUE SWITCH
- ACLS** AUXILIARY CLOSE LIMIT SWITCH
- AOLS** AUXILIARY OPEN LIMIT SWITCH
- IP1** VALVE MIDDLE TRAVEL POSITION SWITCH (No 1)
- IP2** VALVE MIDDLE TRAVEL POSITION SWITCH (No 2)
- IP3** VALVE MIDDLE TRAVEL POSITION SWITCH (No 3)
- IP4** VALVE MIDDLE TRAVEL POSITION SWITCH (No 4)
- CPT** CURRENT POSITION TRANSMITTER
- CTT** CURRENT TORQUE TRANSMITTER
- CPT.LP** CURRENT POSITION TRANSMITTER, LOOP POWER
- CTT.LP** CURRENT TORQUE TRANSMITTER, LOOP POWER
- CTS** CLOSE TORQUE SWITCH
- OTS** OPEN TORQUE SWITCH
- CLS** CLOSE LIMIT SWITCH
- OLS** OPEN LIMIT SWITCH
- TRM** THERMAL PROTECTION DEVICE (MOTOR WIND.)
- HT** ANTI-CONDENSATION HEATER
- BLK** BLINKER SWITCH
- POT** POTENTIOMETER (VALVE POSITION SIGNAL)

**NOTES:**

1. THE TERMINAL PLAN SHOWS THE MULTI-TURN ELECTRIC ACTUATOR IN INTERMEDIATE POSITION, ACTUATOR CLOSES VALVE CLOCKWISE.
2. SEE ACTUATOR USER MANUAL AND DATASHEETS FOR TECHNICAL DATA, PARAMETERS AND DESCRIPTION OF THE ACTUATOR ELECTRIC AND ELECTRONIC EQUIPMENT.
3. THE USER MUST FIT A CLASS 10 OVERLOAD RELAY. THE RELAY MUST BE SIZED ACCORDING TO THE OVERCURRENT PROT. DEVICE SETTING VALUE FOR THE MOTOR.
4. REFER TO THE MOTOR DATA SHEET FOR THIS VALUE. THE OVERLOAD RELAY MUST BE SIZED TO ENSURE THAT IT TRIPS WITHIN 10 SECONDS IN A FAULT CONDITION.
5. THE USER MUST COMPLETE A RISK ASSESSMENT AND IMPLEMENT WHATEVER MEASURES ARE REQUIRED TO ENSURE THAT THE RESULTANT SYSTEM COMPLIES WITH ALL APPLICABLE LEGISLATION.

PARAMETER	VALUE	DESCRIPTION
TYPE	A	MULTI-TURN ELECTRIC ACTUATOR, WITH ATRONIK (MECHANICAL SWITCH MECH.)
MAIN POWER SUPPLY	0	A.C. THREE PHASE
EXTRA CARD No 1	0	NO(WITHOUT)
EXTRA CARD No2	0	NO(WITHOUT)
MOTOR STARTER	0	REVERSIBLE CONTACTOR(STANDARD)
CUSTOMER SUPPLY & BLUETOOTH	0	24VDC±20% AT MAX.POW.OUTPUT 5W
BACKUP SUPPLY & HEATER	2	NO BACKUP SUPPLY, HEATER INCLUDED
EXTRA SWITCH	9	EXTRA LIMIT SWITCHES+EXTRA TORQUE SWITCHES

Lezo - ES  
www.rotork.com

© 2023 Rotork Group of Companies. All rights reserved. This document and its contents may not be reproduced, distributed, transmitted, displayed, published, or broadcast, in whole, or in part, without the prior, express written permission of Rotork Group of Companies.

Title **WD-CKA-CKRA,MSM,3PH,NOEX1,NOEX2,CTOR,CS24,NOBK-HT,ALT**

Created	A.Aashay	2023-09-26	Drawing Number <b>A0000029X</b>	Rev <b>1-0</b>
Checked	A.Aashay	2023-09-26		
Approved	N.Campbell	2023-09-26		

Size A3 Sheet **1** of 2

Template Issue - 2021-05-16 (RCL-PE)

Rev	ECN	Revised	Rev. Approved	Date	Change Description
1-0	-	A.Aashay	N.Campbell	2023-09-26	First issue

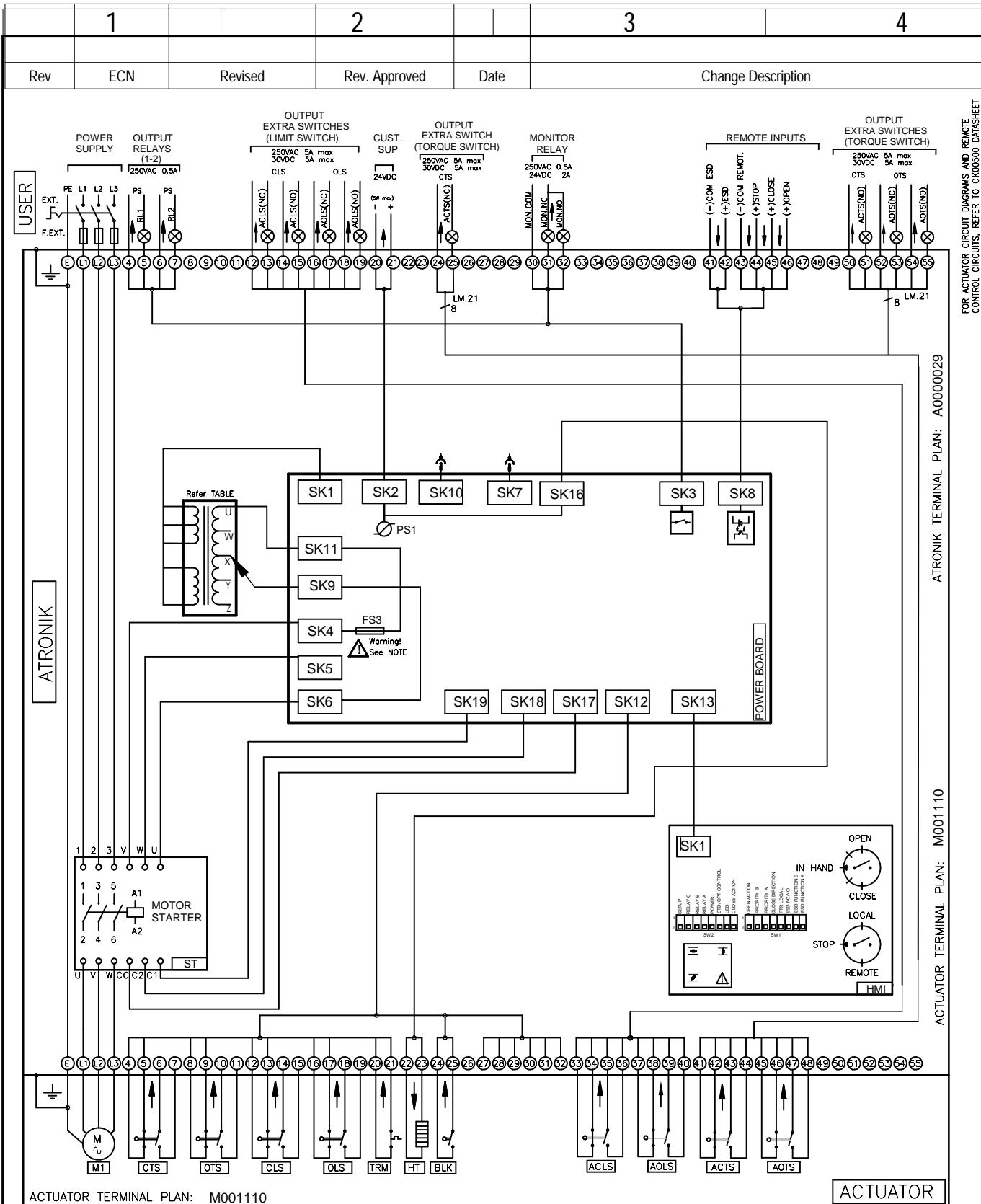

ACTUATOR TERMINAL PLAN: M001110

ACTUATOR

⚠️ WARNING: REFER TO SAFE USE AND INSTALLATION MANUAL OR CK00550 DATASHEET FOR APPROVED FUSES.  
 FS3: SIBA, 70-065-65 1A, 500V, 6.3mmx32mm

TRANSFORMER TAPPING OPTIONS

PRIMARY TAP NOMINAL VOLTAGE (VAC 50/60 Hz)			
TAP	TYPE 1	TYPE 2	TYPE 3
W	110/115	380	500
X	208	400/415	575
Y	220	440	600
Z	230/240	460/480	690

- THE TERMINAL PLAN SHOWS THE MULTI-TURN ELECTRIC ACTUATOR IN INTERMEDIATE POSITION, ACTUATOR CLOSES VALVE CLOCKWISE.
- REFER TO SAFE USE AND INSTALLATION MANUAL AND DATASHEETS FOR TECH. DATA, PARAMETERS AND DESCRIPTION OF THE ACTUATOR ELECTRIC AND ELECTRONIC EQUIPMENT.
- THE USER MUST CONDUCT A RISK ASSESSMENT, AND IMPLEMENT WHATEVER EXTRA SAFETY MEASURES ARE REQUIRED, TO ENSURE THAT THE RESULTANT SYSTEM COMPLIES WITH THE LOW VOLTAGE DIRECTIVE, AND ANY OTHER LEGISLATION IN FORCE AT THE INSTALLATION SITE.
- REFER INSTALLATION MANUAL TO CONFIGURE SW1 AND SW2

Template Issue: 2021-03-16(RCL-PE)



© 2023 Rotork Group of Companies. All rights reserved. This document and its contents may not be reproduced, distributed, transmitted, displayed, published, or broadcast, in whole, or in part, without the prior, express written permission of Rotork Group of Companies.

Title <b>WD-CKA-CKRA,MSM,3PH,NOEX1,NOEX2,CTOR,CS24,NOBK-HT,ALT</b>			
Created	A.Aashay	2023-09-26	Drawing Number <b>A000029X</b>
Checked			Rev <b>1-0</b>
Approved			Size <b>A4</b> Sheet <b>2</b> of <b>2</b>

FOR ACTUATOR CIRCUIT DIAGRAMS AND REMOTE CONTROL CIRCUITS, REFER TO CK00550 DATASHEET

ATRONIK TERMINAL PLAN: A0000029

ACTUATOR TERMINAL PLAN: M001110