

FOR TYPICAL REMOTE CONTROL DETAILS, SEE DOCUMENT
RWS127

TRANSFORMER TAPPING OPTIONS	
Tap	Nominal 50/60Hz
TYPE 1	
W	220/230
X	380/400
Y	400,415/420
Z	440/460
FUSE FS 1=250mA ANTI-SURGE	
TYPE 2	
W	346/380
X	480/500
Y	240/240
Z	550/575
FUSE FS 1=250mA ANTI-SURGE	
TYPE 3	
X	660/660-690
Y	690/-
FUSE FS 1=150mA ANTI-SURGE	

REFER TO SHEET 2 FOR NOTES & OPTION PCB'S IF FITTED

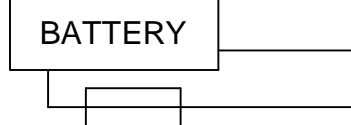

FS2 (IF FITTED) 100mA

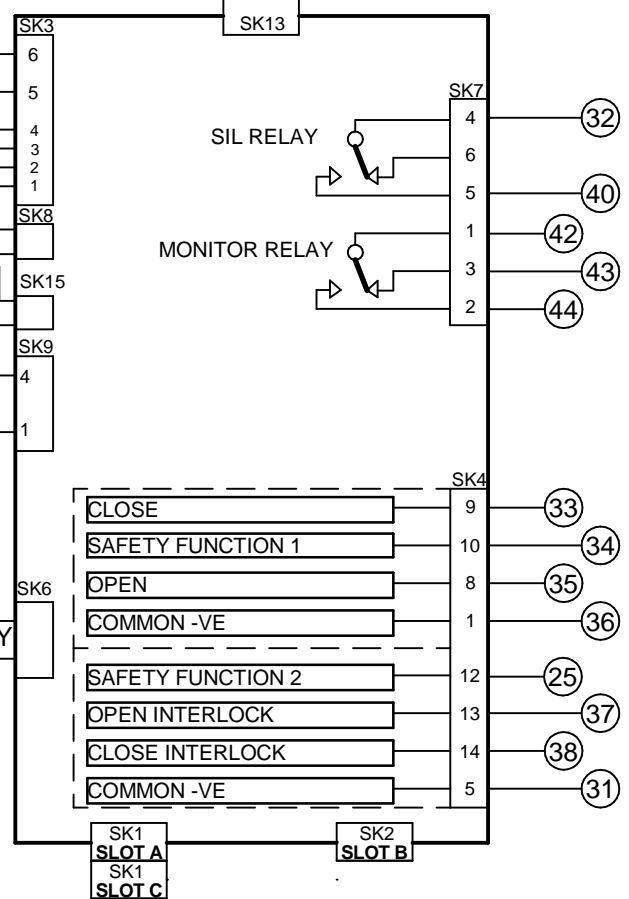
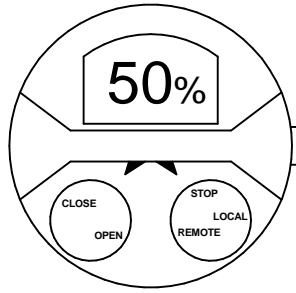

SIL NOTES (Superseding Sheet 2 Notes)

Independently Certified to IEC61508-2 (2010) as an element suitable for use in safety related systems up to and including SIL 2 (1001) and SIL 3 (1002). Must be installed, commissioned, tested and operated fully in accordance with the Safety Manual. Refer to SIL Safety Manual - PUB002-057

SIL STAYPUT (Safety Function 1): The control signal must be applied to terminal 34 before an open or closed control signal will operate the actuator. This is a high demand safety function, actuator will not move spuriously.

If the safety function is configured for SIL STAYPUT only, terminal 25 will be a standard (Non-SIL) ESD terminal, as per PUB002-040.

SIL MOVE TO LIMIT (Safety Function 2): The control signal must be removed to terminal 25 to cause the actuator to move to the configured end of travel position (Open or Close limit). This is not a maintained input, SF2 control signal must be removed for the duration of operation to the configured limit position. This is a low demand safety function.

If the safety function is configured for SIL MOVE TO LIMIT (SF2) ONLY, terminal 34 will be a standard Stop/Maintain input in accordance with PUB002-041.

Safety Function 1 + Safety Function 2: Where both safety functions are required, the priority and functions must be configured in accordance with the SIL Safety Manual - PUB002-057. The common for SF1 (terminal 36) and SF2 (terminal 31) are independent allowing the control signal to be derived from separate, independent systems. If required, where signals are derived from the same system, the commons can be linked together.

SF1 and SF2 Signals must be within the range 16-60VDC, positive supply switched only.

Iss	Date	Chkd	Revision Details	www.rotork.com	IQ + SIL + FOLOMATIC & CPT + PAKSCAN	
1	050124	JC1	FIRST ISSUE		ROTORK CONTROLS LTD BATH, BA1 3JQ ENGLAND Tel:01225-733200	ROTORK CONTROLS INC ROCHESTER NY 14624, USA Tel:585-247-2304
					Circuit Diagram Number 703K2000	Issue No 1 Sheet 1 of 2
					B1 C1 B2 C2	

SLOT A

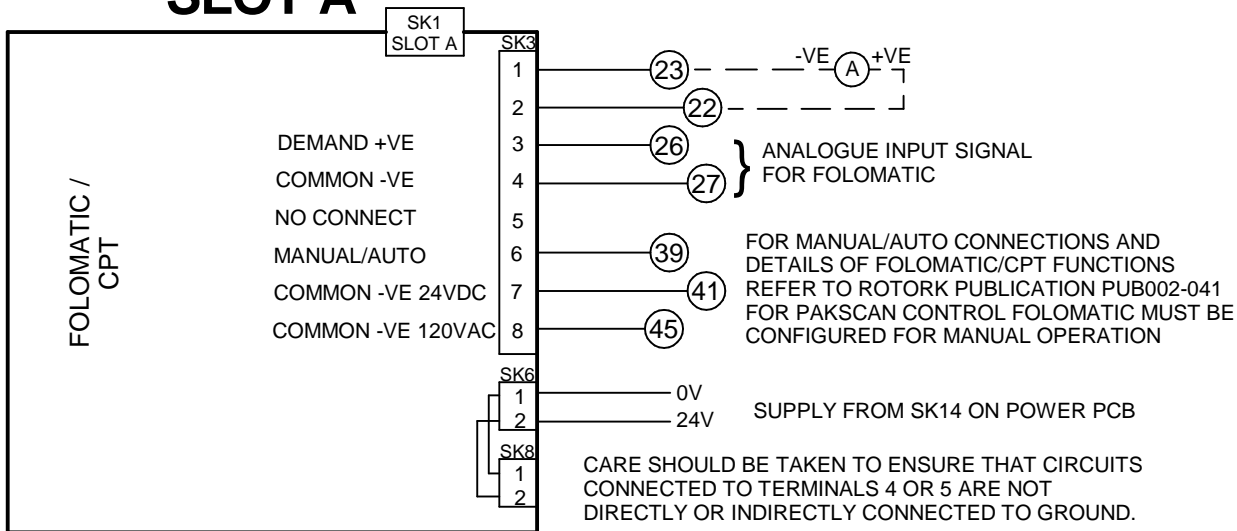

SLOT B

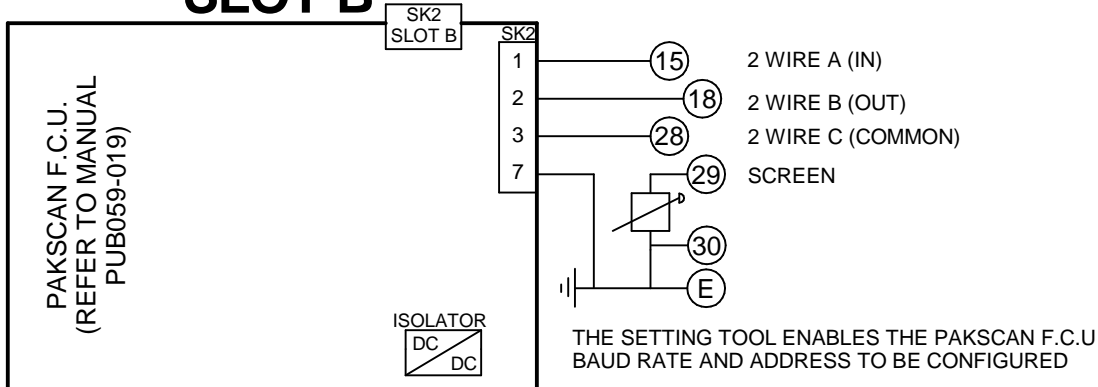

SLOT C

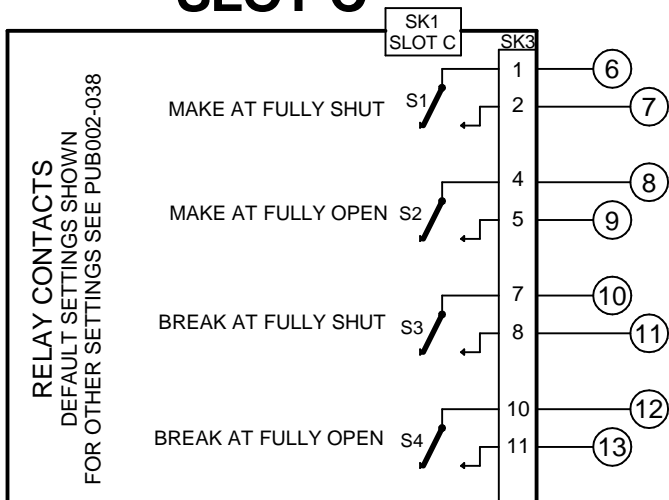

NOTES

1.FUSES:

- PS1 is a self-resetting fuse.
- Refer to publication PUB002-039 for approved fuses FS1 and FS2.
- Actuator rated voltage specified on nameplate. Voltage tolerance +/-10%, applies for rated torque performance; duty cycle is not guaranteed.

2.REMOTE CONTROL:

- For typical remote control circuits refer to:
 - RWS indicated or PUB002-041.
- For DC and AC control, connect -ve/0V to terminal 36.
- (For negative switch / positive common, refer to RWS indicated).
- Control signal threshold voltages:
 - DC: "on" ≥16Vdc / "off" ≤8Vdc, max 60Vdc.
 - AC: "on" ≥60Vac / "off" ≤40Vac, max 120Vac.
- Control signal duration to be 300ms minimum.
- Maximum current drawn from remote control signals is:
 - 8mA at 24Vdc or 12mA at 120Vac.
- Supply provided on terminals 4 & 5:
 - Intended for remote control.
 - Max external load 5W at 24Vdc / 5VA at 120Vac

3.INDICATION:

- For typical position, status and alarm indication see PUB002-041.
- "S" contacts are user configurable and are shown in their default setting.
- Refer to PUB002-040 for functions and configuration instructions.
- Monitor Relay indicates actuator availability for remote control (shown "unavailable"). It can be configured to exclude local/remote selection.
- Refer to PUB002-040 for monitored functions and configuration instructions.
- Voltage applied to indication contacts must not exceed 150Vac
- Individual Switch current must not exceed 3.5A inductive, 5A resistive and no more than 8A in total for all 4 contacts.

4.BATTERY:

- Battery maintains local and remote "S" contact indication only.
- Refer to installation manual for approved replacement battery types.