

FOR TYPICAL REMOTE CONTROL
DETAILS, SEE DOCUMENT
RWS100

PLUG SELECTED VOLTAGE WIRE INTO
TERMINAL "T"
PLACE TWO REMAINING WIRES INTO
POSITIONS "P"
(ORDER NOT IMPORTANT)

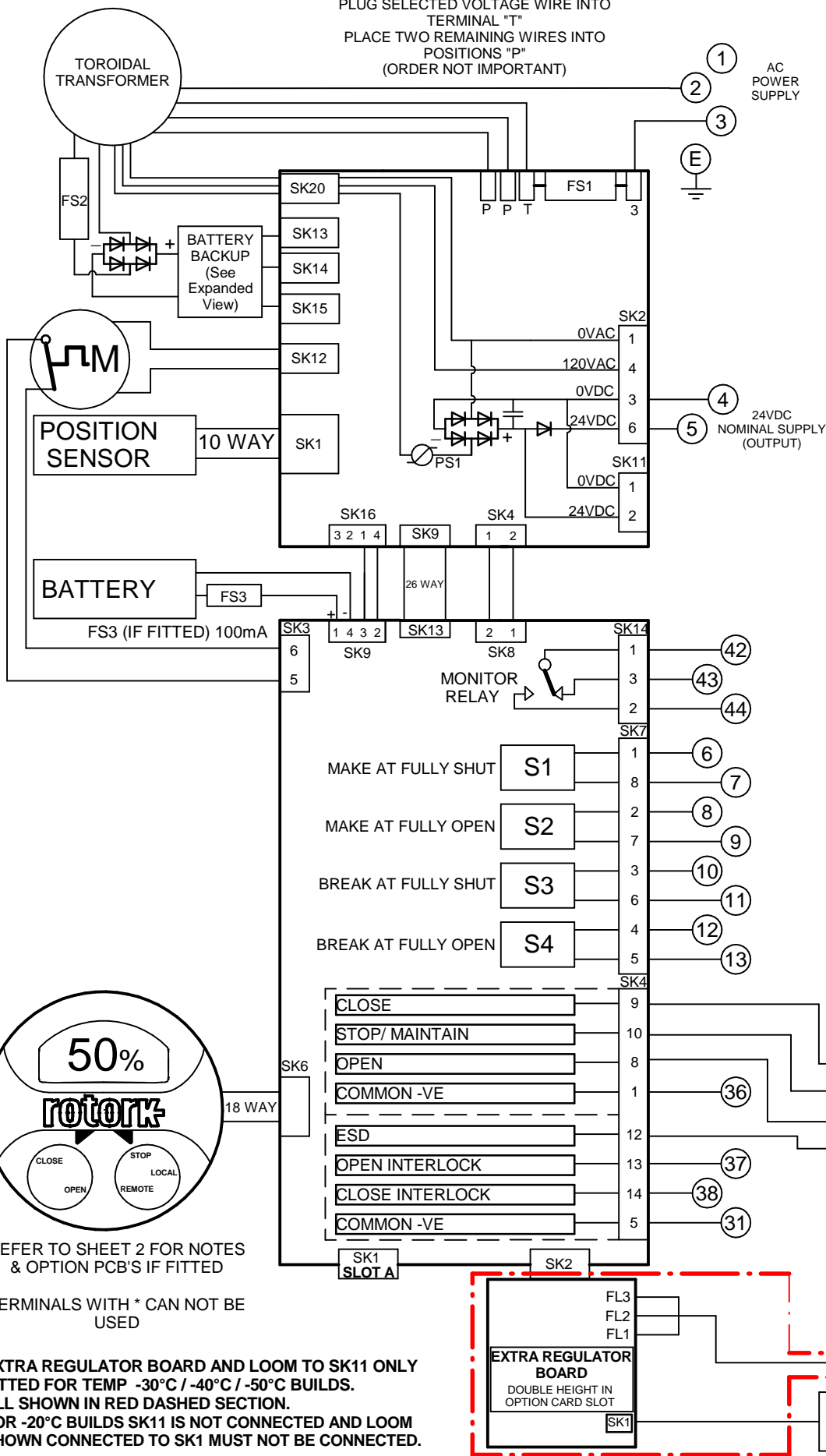

TRANSFORMER VOLTAGE OPTIONS:
CONNECT CORRESPONDING COLOUR TO "T"

TYPE 1		
GREY	100V	FS1 - 5A ANTISURGE
PURPLE	110V	
BROWN	120V	
TYPE 2		
GREY	200V	FS1 - 2.5A ANTISURGE
PURPLE	230V	
BROWN	270V	
TYPE 3		
GREY	380V	FS1 - 2.0A ANTISURGE
PURPLE	400V	
BROWN	415V	
TYPE 4		
GREY	480V	FS1 - 2.0A ANTISURGE
PURPLE	575V	
BROWN	690V	

FS2 - 20A ATO FAST ACTING ALL TYPES

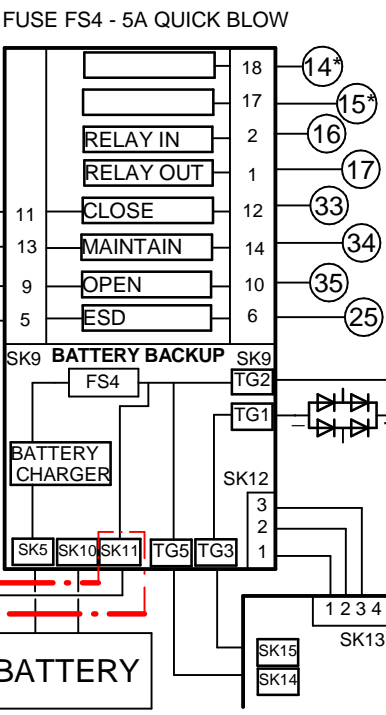
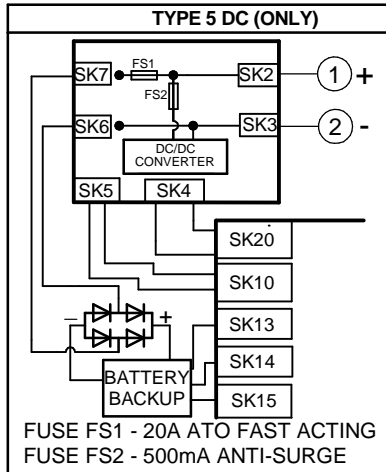

REFER TO SHEET 2 FOR NOTES
& OPTION PCB'S IF FITTED

TERMINALS WITH * CAN NOT BE
USED

EXTRA REGULATOR BOARD AND LOOM TO SK11 ONLY
FITTED FOR TEMP -30°C / -40°C / -50°C BUILDS.
ALL SHOWN IN RED DASHED SECTION.
FOR -20°C BUILDS SK11 IS NOT CONNECTED AND LOOM
SHOWN CONNECTED TO SK1 MUST NOT BE CONNECTED.

Iss	Date	Chkd	Revision Details
1	120324	JC1	First Issue

www.rotork.com

ROTORK CONTROLS LTD
BATH, BA1 3JQ
ENGLAND
Tel:01225-733200

ROTORK CONTROLS INC
ROCHESTER
NY 14624, USA
Tel:585-247-2304

IQTM EP BATTERY BACKUP + PROFIBUS DUAL
CHANNEL + PROFIBUS DISCONNECT

Drawn by: PJW
Date : 120324
Base WD: 470P3004
Job No : - -
MI No : - -

Circuit Diagram Number
470P3004

Issue No
1

Sheet
1
of 2

B1	C1	B2	C2						
----	----	----	----	--	--	--	--	--	--

CIRCUIT DRAWN WITH POWER SUPPLY OFF

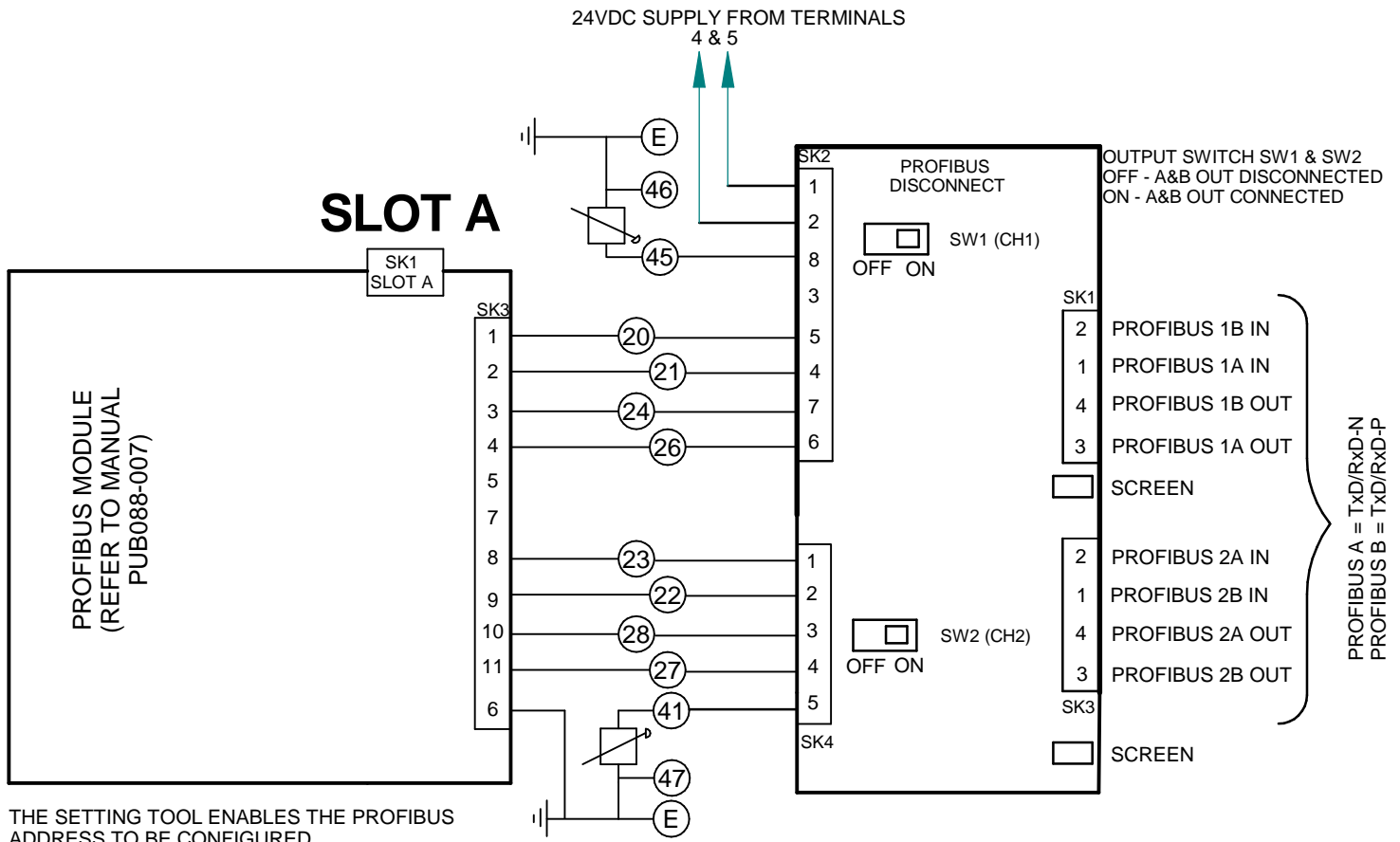

NOTES

1.FUSES:

- PS1 is a self-resetting fuse.
- Refer to publication PUB002-065 for approved fuses FS1 and FS2.
- Actuator rated voltage specified on nameplate. Voltage tolerance +/-10% applies for rated torque performance; duty cycle is not guaranteed.

2.REMOTE CONTROL:

- For typical remote control circuits refer to:
 - RWS indicated or PUB002-041.
- For DC control, connect -ve to terminal 36.
- (For negative switch / positive common, refer to RWS indicated).
- Control signal threshold voltages:
 - DC: "on" ≥16Vdc / "off" ≤8Vdc, max 60Vdc.
- Control signal duration to be 100ms minimum.
- Maximum current drawn from remote control signals is:
 - 8mA at 24Vdc.
- Supply provided on terminals 4 & 5:
 - Intended for remote control.
 - Max external load 5W at 24Vdc

3.INDICATION:

- For typical position, status and alarm indication see PUB002-041.
- "S" contacts are user configurable and are shown in their default setting.
- Refer to PUB002-040 for functions and configuration instructions.
- Monitor Relay indicates actuator availability for remote control (shown "unavailable"). It can be configured to exclude local/remote selection.
- Refer to PUB002-040 for monitored functions and configuration instructions.
- Voltage applied to indication contacts must not exceed 150Vac
- Individual Switch current must not exceed 3.5A inductive, 5A resistive and no more than 8A in total for all 4 contacts.

4.BATTERY:

- Battery maintains local and remote "S" contact indication only.
- Refer to installation manual for approved replacement battery types.

See Sheet 1 for all Revision details/information

Circuit Diagram Number	Issue No	Sheet
470P3004	1	2 of 2