

PLUG-AND-SOCKET CONNECTOR LAYOUT

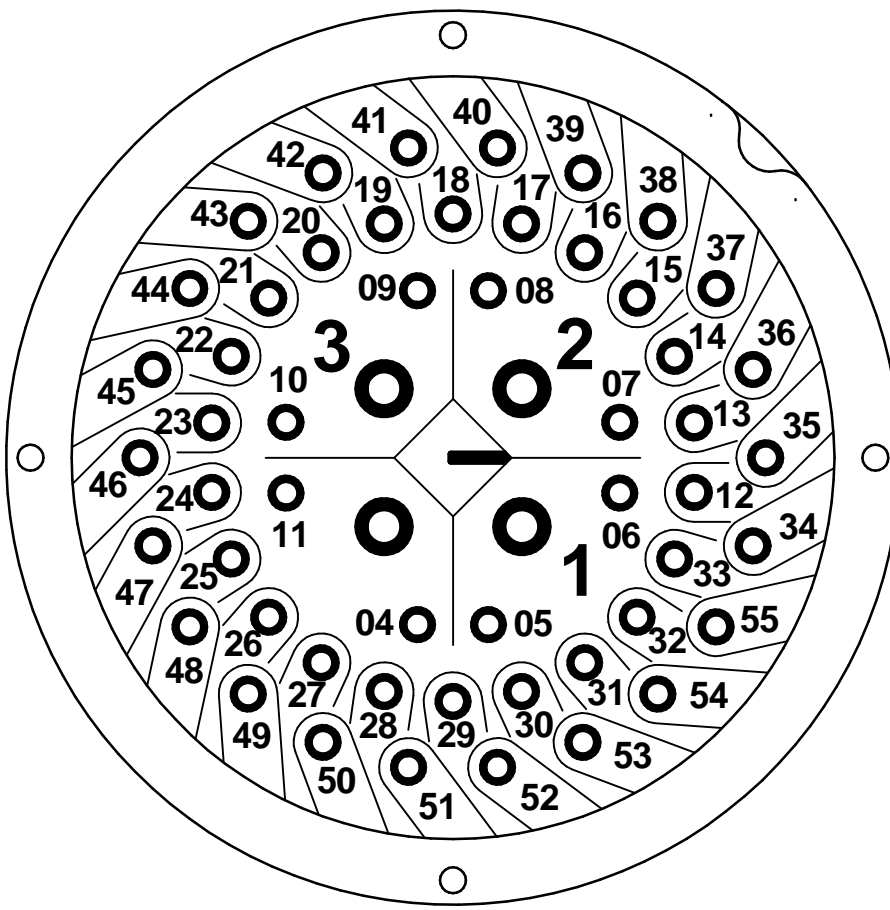

LEGENDS:

- M1** ELECTRIC MOTOR
- R1** RELAY OUTPUT No1 (SETTABLE)
- R2** RELAY OUTPUT No2 (SETTABLE)
- R3** RELAY OUTPUT No3 (SETTABLE)
- R4** RELAY OUTPUT No4 (SETTABLE)
- R5** RELAY OUTPUT No5 (SETTABLE)
- R6** RELAY OUTPUT No6 (SETTABLE)
- R7** RELAY OUTPUT No7 (SETTABLE)
- R8** RELAY OUTPUT No8 (SETTABLE)
- R9** RELAY OUTPUT No9 (SETTABLE)
- R10** RELAY OUTPUT No10 (SETTABLE)
- R11** RELAY OUTPUT No11 (SETTABLE)
- R12** RELAY OUTPUT No12 (SETTABLE)
- CS** CUSTOMER SUPPLY
- BS** BACKUP SUPPLY
- POSITIONER** POSITIONER IN/OUT ANALOG SIGNAL
- POSITIONER.LP** POSITIONER IN/OUT ANALOG SIGNAL, LOOP POWER
- MONIT.** MONITOR RELAY
- FIELDBUS** FIELDBUS CARD
- REMOTE** REMOTE INPUT CARDS
- ACTS** AUXILIARY CLOSE TORQUE SWITCH
- AOTS** AUXILIARY OPEN TORQUE SWITCH
- ACLS** AUXILIARY CLOSE LIMIT SWITCH
- AOLS** AUXILIARY OPEN LIMIT SWITCH
- IP1** VALVE MIDDLE TRAVEL POSITION SWITCH (No 1)
- IP2** VALVE MIDDLE TRAVEL POSITION SWITCH (No 2)
- IP3** VALVE MIDDLE TRAVEL POSITION SWITCH (No 3)
- IP4** VALVE MIDDLE TRAVEL POSITION SWITCH (No 4)
- CPT** CURRENT POSITION TRANSMITTER
- CTT** CURRENT TORQUE TRANSMITTER
- CPT.LP** CURRENT POSITION TRANSMITTER, LOOP POWER
- CTT.LP** CURRENT TORQUE TRANSMITTER, LOOP POWER
- CTS** CLOSE TORQUE SWITCH
- OTS** OPEN TORQUE SWITCH
- CLS** CLOSE LIMIT SWITCH
- OLS** OPEN LIMIT SWITCH
- TRM** THERMAL PROTECTION DEVICE (MOTOR WIND.)
- HT** ANTI-CONDENSATION HEATER
- BLK** BLINKER SWITCH
- POT** POTENTIOMETER (VALVE POSITION SIGNAL)
- CPT** CURRENT POSITION TRANSMITTER (VALVE POSITION SIGNAL)
- DSM** DIGITAL SWITCH MECHANISM (ELECTRONIC VALVE POSITION AND TORQUE SIGNALS)

NOTES:

1. THE TERMINAL PLAN SHOWS THE MULTI-TURN ELECTRIC ACTUATOR IN INTERMEDIATE POSITION, ACTUATOR CLOSES VALVE CLOCKWISE.
2. SEE ACTUATOR USER MANUAL AND DATASHEETS FOR TECHNICAL DATA, PARAMETERS AND DESCRIPTION OF THE ACTUATOR ELECTRIC AND ELECTRONIC EQUIPMENT.
3. IF THE ACTUATOR IS CONFIGURED TO BYPASS THE MOTOR PROTECTION THERMOSTAT (TRM), THE ACTUATOR WILL NO LONGER COMPLY WITH THE ESSENTIAL SAFETY REQUIREMENTS.
4. THE USER MUST FIT A CLASS 10 OVERLOAD RELAY. THE RELAY MUST BE SIZED ACCORDING TO THE OVERCURRENT PROT. DEVICE SETTING VALUE FOR THE MOTOR.
5. REFER TO THE MOTOR DATA SHEET FOR THIS VALUE. THE OVERLOAD RELAY MUST BE SIZED TO ENSURE THAT IT TRIPS WITHIN 10 SECONDS IN A FAULT CONDITION.
6. THE USER MUST COMPLETE A RISK ASSESSMENT AND IMPLEMENT WHATEVER MEASURES ARE REQUIRED TO ENSURE THAT THE RESULTANT SYSTEM COMPLIES WITH ALL APPLICABLE LEGISLATION.

PARAMETER	VALUE	DESCRIPTION
TYPE	J	MULTI-TURN ELECTRIC ACTUATOR, WITH CENTRONIK (DIGITAL SWITCH MECH.) REMOTE MOUNTING VERSION
MAIN POWER SUPPLY	0	A.C. THREE PHASE
EXTRA CARD No 1	J	POSITIONER + MAN/AUTO SWITCH
EXTRA CARD No2	3	MODBUS RTU
MOTOR STARTER	1	SOLID STATE RELAY (THYRISTORS)
CUSTOMER SUPPLY & BLUETOOTH	2	24VDC±20% AT MAX.POW.OUTPUT 5W, AND BLUETOOTH CARD FOR REMOTE SETTING TOOL
BACKUP SUPPLY & HEATER	3	YES(BACK UP SUPPLY), HEATER INCLUDED
EXTRA SWITCH	4	4 MIDDLE TRAVEL SWITCHES (SETTABLE NO/NC CONTACT, BY CAM + VID)

Lezo - ES
www.rotork.com

© 2024 Rotork Group of Companies. All rights reserved. This document and its contents may not be reproduced, distributed, transmitted, displayed, published, or broadcast, in whole, or in part, without the prior, express written permission of Rotork Group of Companies.

Title **WD CKC-CKRC,DSM,3PH,POSC,MB1,SSS,CS24-BT,BS-HT,IP4**

Created	A.Aashay	2024-05-02	Drawing Number J0J31234X	Rev 1-0
Checked	A.Aashay	2024-05-02		
Approved	N.Campbell	2024-05-02		

Size **A3** Sheet **1** of **2**

Template Issue - 2021-05-16 (RCL-PE)

Rev	ECN	Revised	Rev. Approved	Date	Change Description
1-0		A.Aashay	N.Campbell	2024-05-02	First issue

FOR ACTUATOR CIRCUIT DIAGRAMS AND REMOTE CONTROL CIRCUITS, REFER TO CK00500 DATASHEET
 REMOTE MOUNTING ASSEMBLY INSTRUCTIONS, REFER TO CK00800 DATASHEET

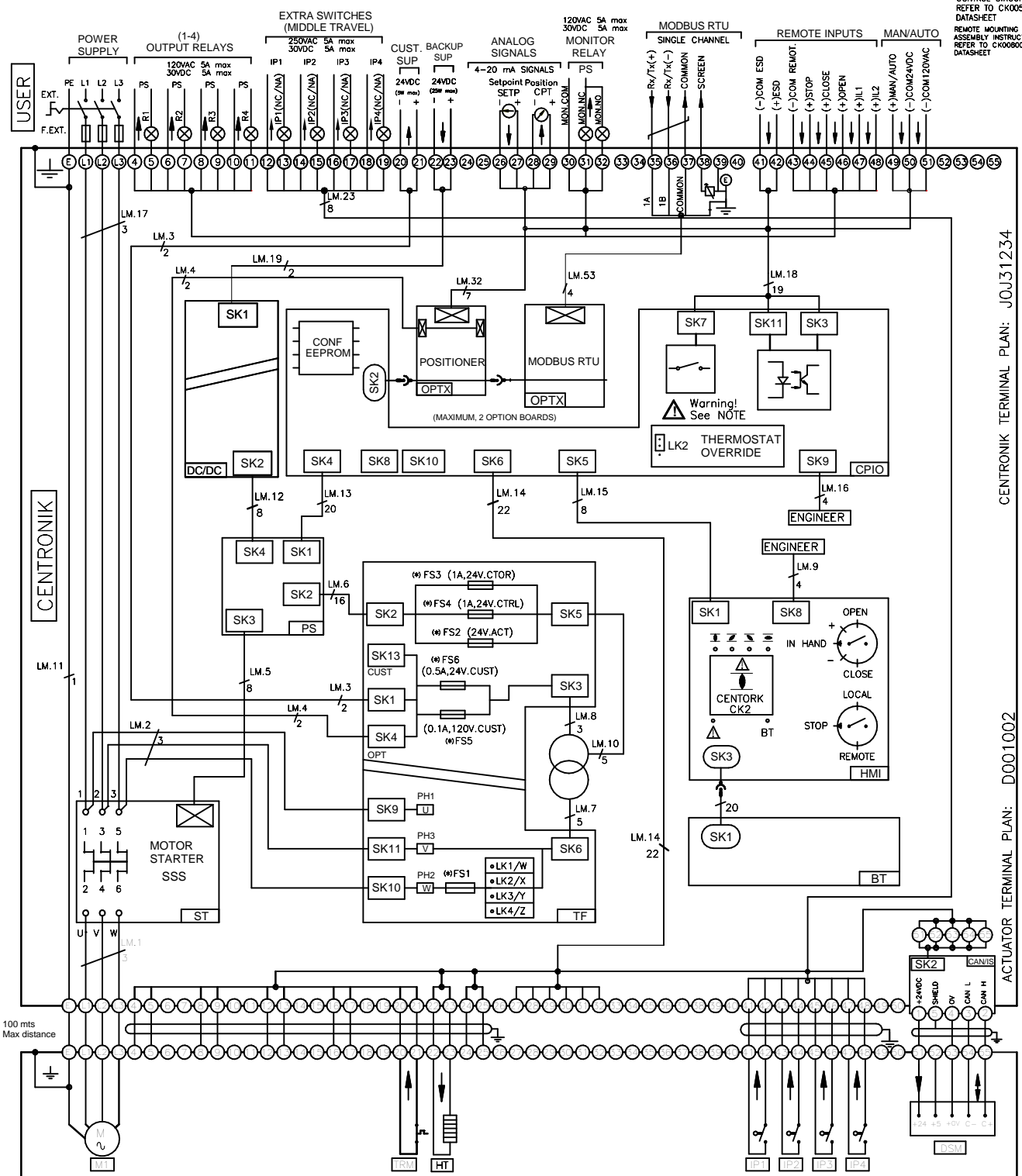

ACTUATOR TERMINAL PLAN: D001002

⚠ WARNING: REFER TO SAFE USE AND INSTALLATION MANUAL OR CK00500 DATASHEET FOR APPROVED FUSES.
 FS1: ACCORDING TO THE POWER SUPPLY VOLTAGE 110VAC/115VAC: FS1 (0,5 A)
 ANY OTHER VOLTAGE: FS1 (0,25 A)

THE TERMINAL PLAN SHOWS THE MULTI-TURN ELECTRIC ACTUATOR IN INTERMEDIATE POSITION, ACTUATOR CLOSES VALVE CLOCKWISE.
 REFER TO SAFE USE AND INSTALLATION MANUAL AND DATASHEETS FOR TECH. DATA, PARAMETERS AND DESCRIPTION OF THE ACTUATOR ELECTRIC AND ELECTRONIC EQUIPMENT.
 ACTUATORS WITH SOLID STATE STARTER (SSS), THE ACTUATOR MUST BE PROTECTED USING SUITABLE RATED HIGH SPEED SEMI-CONDUCTOR FUSES ON THE INCOMING SUPPLY
 IF THE ACTUATOR IS CONFIGURED TO BYPASS THE MOTOR PROTECTION THERMOSTAT (TRM), THE ACTUATOR WILL NO LONGER COMPLY WITH THE ESSENTIAL SAFETY REQUIREMENTS.
 THE USER MUST CONDUCT A RISK ASSESSMENT, AND IMPLEMENT WHATEVER EXTRA SAFETY MEASURES ARE REQUIRED, TO ENSURE THAT THE RESULTANT SYSTEM COMPLIES WITH THE LOW VOLTAGE DIRECTIVE, AND ANY OTHER LEGISLATION IN FORCE AT THE INSTALLATION SITE.

TRANSFORMER TAPPING OPTIONS

TAP	LV	PRIMARY TAP NOMINAL VOLTAGE (VAC 50/60Hz)		
		EU	HV	
LK1	W	110/115/120	380	460
LK2	X	220/230	400	480
LK3	Y	240	415	500
LK4	Z	n/a	440	600

Template Issue: 2021-03-16(RCL-PE)

© 2024 Rotork Group of Companies. All rights reserved. This document and its contents may not be reproduced, distributed, transmitted, displayed, published, or broadcast, in whole, or in part, without the prior, express written permission of Rotork Group of Companies.

Lezo - ES
 www.rotork.com

Title WD KCK-CKRC,DSM,3PH,POSC,MB1,SSS,CS24-BT,BS-HT,IP4			
Created	A.Aashay	2024-05-02	Drawing Number JOJ31234X
Checked			Rev 1-0
Approved			Size A4 Sheet 2 of 2

A
B
C
D
E
F

CENTRONIK TERMINAL PLAN: JOJ31234

ACTUATOR TERMINAL PLAN: D001002