



Keeping the World Flowing
for Future Generations



Model T6000

Electro-Pneumatic I/P, E/P Transducer

Rotork Fairchild's T6000 Series is designed for precision applications providing maximum versatility. The modular construction permits any basic unit to be used in the explosion-proof, rack, wall, pipe, panel, DIN rail or 3, 5, 10, or 15 unit manifold configurations. Servicing or calibration is quick and easy.

Features and Benefits

- Field reversible feature provides output which is directly or inversely proportional to the input signal
- RFI/EMI protection eliminates susceptibility to electromagnetic and radio interference
- Six output pressure ranges meet final control element requirements
- Six input signal ranges meet most process and machine requirements
- Compact size permits use in space restricted areas
- Explosion-proof NEMA4X , IP65, Type 4 Enclosure available for outdoor and indoor installations
- Input and Output ports on both front and back simplifies pneumatic piping

Operating Principles

Standard Range

The T6000 Series is an electro-pneumatic device that converts a DC input signal to a pneumatic output. This device is made up of two sections, the Primary Converting Section and the Pneumatic Relay Section. The coil and suspension spring, in the Primary Converting Section, is used as a flapper. Together the flapper and nozzle work to control the signal pressure. The signal pressure acts on the upper control diaphragm, in the Pneumatic Relay Section, which sets the output pressure. The output pressure is sensed by the lower control diaphragm, in the Pneumatic Relay Section, which maintains the output pressure.

Extended Range

The Extended Unit is made up of three sections, the Primary Control Section, the Pneumatic Relay Section, and an additional Pneumatic Relay Section. The additional Relay Section is used to amplify the output pressure.



Model T6000 Electro-Pneumatic I/P, E/P Transducer

Dimensions

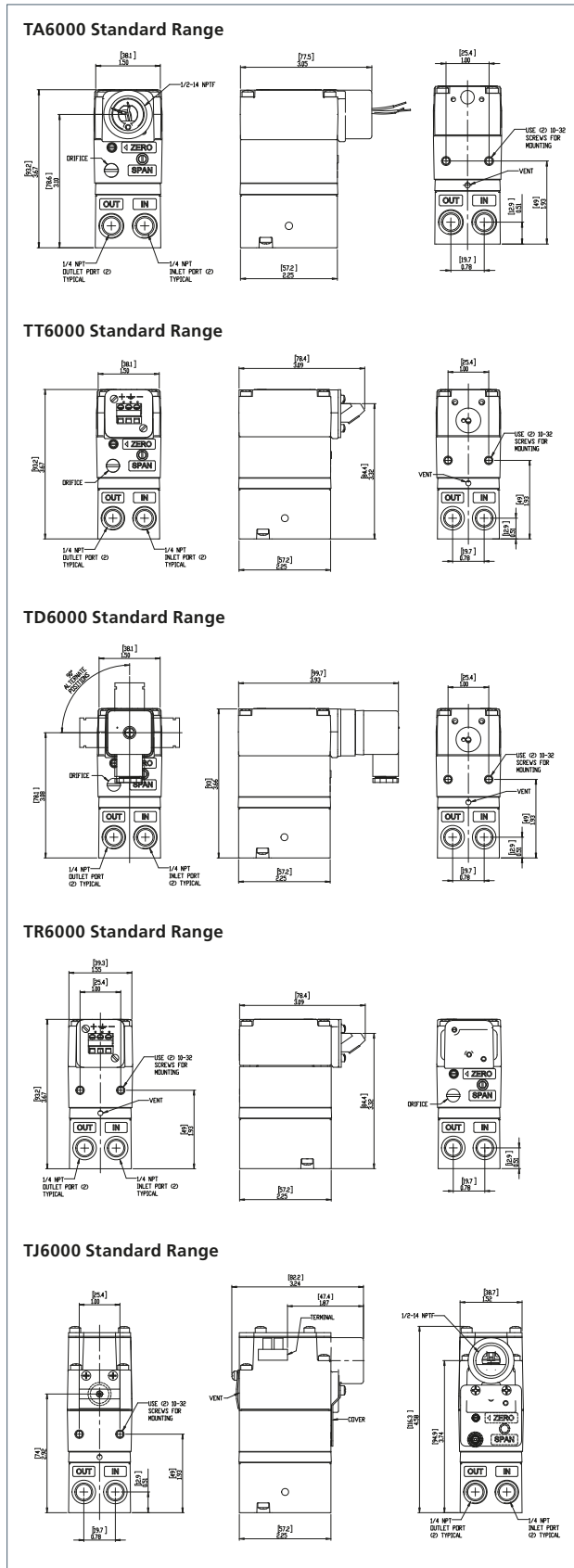

Specifications (Standard Range)

	psig [BAR] (kPa)	3-15 [0.2-1.0] (20-100)	3-27 [0.2-1.8] (20-180)	6-30 [0.4-2.0] (40-200)
Output Range				
Supply Pressure¹	psig [BAR] (kPa)	20-120 [1.5-8.0] (150-800)	32-120 [2.2-8.0] (220-800)	35-120 [2.4-8.0] (240-800)
Minimum Span	psig [BAR] (kPa)	5 [0.35] (35)	10 [0.7] (70)	10 [0.7] (70)
Impedance (OHMS) / Input Signal	4-20 mA	197	204	204
	10-50 mA	79	82	82
	0-5 VDC	550	532	532
	0-10 VDC	1100	1064	1064
	1-5 VDC	500	483	483
	1-9 VDC	1000	970	970
Air Consumption (per ISA S51.1) SCFH		5.0 (.14m ³ /HR)	6.0 (.17m ³ /HR)	6.0 (.17m ³ /HR)
Independent Linearity (per ISA S51.1)		+0.5% FS	+0.5% FS	+0.5% FS
Hysteresis & Repeatability (per ISA S51.1)		0.25% FS	0.25% FS	0.25% FS

Supply Pressure Effect on Output

- 0.25 psig, [0.17 BAR], (1.7 kPa) for a 25 psig, (1.7 BAR), (170 kPa) supply change

Flow Rate (SCFM)

- 2.5 (4.25m³/HR) @ 25 psig, (1.7 BAR, (170 kPa) Supply & 9 psig, [0.6 BAR], (60 kPa) output
- 9.0 (15.3m³/HR) @ 120 psig, [8.0 BAR, (800 kPa) Supply & 9 psig, [0.6 BAR], (60 kPa) output

EMC Compatibility

- Meets EMC Directive 2014/30/EU per the EMC standard EN 61326-1:2013, Industrial Environments

Temperature Range (per ISA S51.1)

- -40 °C to +70 °C (-40 °F to +158 °F)

Materials of Construction

- Body and Housing: Aluminum
- Trim: Zinc Plated Steel
- Diaphragm: Nitrile
- Orifice: Nickel Plated Brass

¹ Supply Pressure must be no less than 5 psig, [0.35 BAR], (35 kPa) above minimum output.

NOTE: Model TR6000 Transducer is designed for use with the TR Rack Kit. Physically, it is the same as the TT6000 Unit except that the terminal block has been rotated to the rear.

Model T6000 Electro-Pneumatic I/P, E/P Transducer

Dimensions

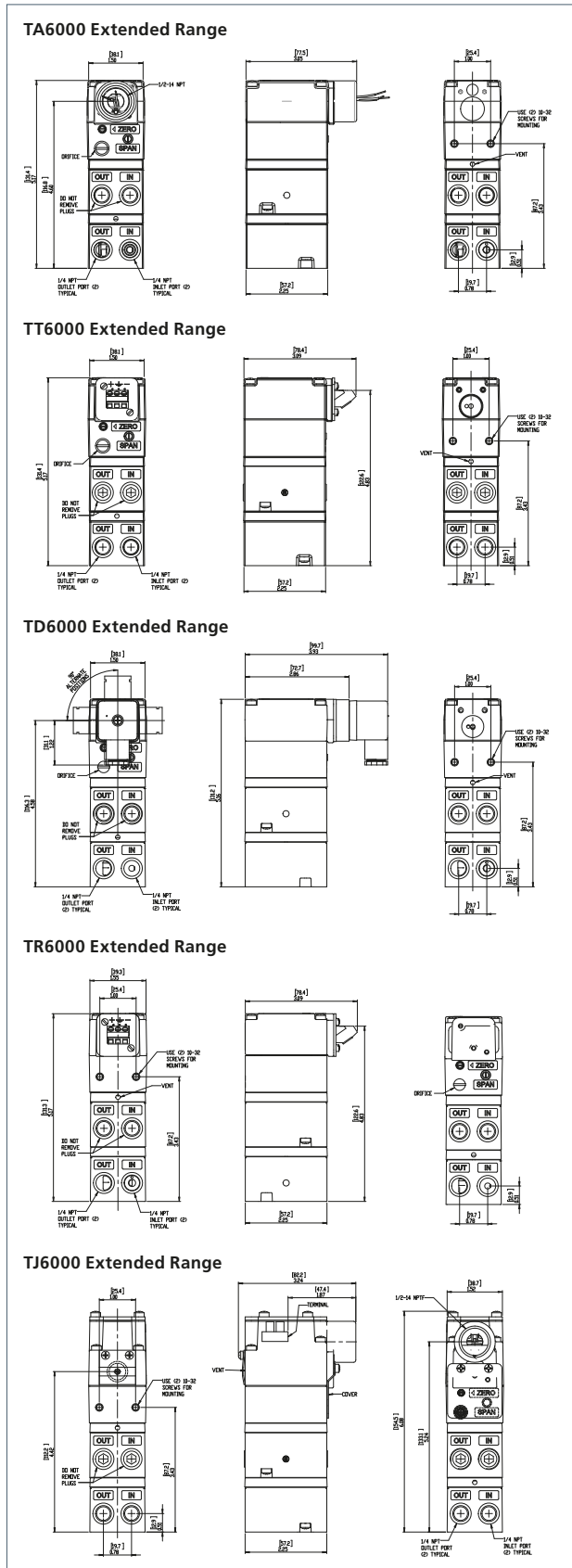

Specifications (Extended Range)

Output Range	psig [BAR] (kPa)	0-30 [0-2.0] (0-200)	0-60 [0-4.0] (0-400)	0-120 [0-8.0] (0-800)
Supply Pressure ¹	psig [BAR] (kPa)	35-150 [2.5-10.0] (250-1000)	65-150 [4.6-10.0] (460-1000)	125-150 [8.8-10.0] (880-1000)
Minimum Span	psig [BAR] (kPa)	12 [0.8] (80)	25 [1.5] (150)	50 [3.5] (350)
Impedance (OHMS) / Input Signal	4-20 mA	250	256	270
	10-50 mA	100	103	108
	0-5 VDC	439	469	446
	0-10 VDC	878	938	893
	1-5 VDC	400	453	430
1-9 VDC	800	750	714	
Air Consumption (per ISA S51.1) SCFH		12.0 (.34m ³ /HR)	13.0 (.36m ³ /HR)	17.0 (.48m ³ /HR)
Independent Linearity (per ISA S51.1)		±0.75% FS	±1.0% FS	±1.0% FS
Hysteresis & Repeatability (per ISA S51.1)	<1.0% FS @ 35 psig [2.5 BAR] (250 kPa)	<1.0% FS @ 65 psig [4.6 BAR] (460 kPa)	<1.0% FS @ 125 psig [8.8 BAR] (880 kPa)	
	Supply Pressure Effect on Output For a 25 psig, (1.7 BAR), (170 kPa) supply change	psig [BAR] (kPa)	0.5 [0.03] (4.0)	1.0 [0.07] (7.0)

Flow Rate (SCFM)

- 11 (18.7 m³/HR) @ 150 psig, [10 BAR], (1000 kPa) supply & 9 psig, [0.6 BAR] (60 kPa) output

EMC Compatibility

- Meets EMC Directive 2014/30/EU per the EMC standard EN 61326-1:2013, Industrial Environments

Temperature Range (per ISA S51.1)

- -40 °C to +70 °C (-40 °F to +158 °F)

Materials of Construction





- Body and Housing: Aluminum
- Trim: Zinc Plated Steel
- Diaphragm: Nitrile
- Orifice: Nickel Plated Brass

¹ Supply Pressure must be no less than 5 psig, [0.35 BAR], (35 kPa) above minimum output.

NOTE: Model TR6000 Transducer is designed for use with the TR Rack Kit. Physically, it is the same as the TT6000 Unit except that the terminal block has been rotated to the rear.

Model T6000 Electro-Pneumatic I/P, E/P Transducer

Hazardous Area Specifications

	Intrinsically Safe	Intrinsically Safe Parameters												
FM	Class I, II, III, Div 1, Groups A, B, C, D, E, F, G T4 Class I, Zone 0, AEx ia IIC T4 NI - Class I, Div 2, A, B, C, D (Option W) Type 3R enclosure Type 4, IP65 enclosure (Option W) T4: T _a = -40 to +80 °C	Entity Parameters/Non Incendive Field Wiring Parameters: <table border="1"> <tr> <td>V_{max}¹ = 28 V</td> <td>C_i³ = 0 μF</td> </tr> <tr> <td>I_{max}² = 100 mA</td> <td>L_i⁴ = 3 mH</td> </tr> <tr> <td>¹V_{max} = Max Voltage</td> <td>³C_i = Capacitance</td> </tr> <tr> <td>²I_{max} = Max Current</td> <td>⁴L_i = Inductance</td> </tr> </table>	V _{max} ¹ = 28 V	C _i ³ = 0 μF	I _{max} ² = 100 mA	L _i ⁴ = 3 mH	¹ V _{max} = Max Voltage	³ C _i = Capacitance	² I _{max} = Max Current	⁴ L _i = Inductance				
V _{max} ¹ = 28 V	C _i ³ = 0 μF													
I _{max} ² = 100 mA	L _i ⁴ = 3 mH													
¹ V _{max} = Max Voltage	³ C _i = Capacitance													
² I _{max} = Max Current	⁴ L _i = Inductance													
CSA	Class I, II, III, Div 1, Groups A, B, C, D, E, F, G Class I, II, III, Div 2, Groups A, B, C, D, E, F, G TA, TD, TJ, IP65 enclosure (Option W) Type 4: TA, TJ T4: T _a = -40 to +80 °C	Approvals are valid when connected through a Shunt Zener Diode Safety Barrier meeting the following parametric requirements: <table border="1"> <tr> <td>System Type 1: Single Channel Polarized Rated: 28V Max. 300 Ohm Min.</td> </tr> <tr> <td>System Type 2: Dual Channel Polarized Rated: 28V Max. 300 Ohm Min.</td> </tr> <tr> <td>System Type 3: a. 28V Max. 300 Ohm Min. & 10V Max. 50 Ohm Min. return b. 28.5V Max. 300 Ohm Min. & 9V Max. 50 Ohm Min. return</td> </tr> </table>	System Type 1: Single Channel Polarized Rated: 28V Max. 300 Ohm Min.	System Type 2: Dual Channel Polarized Rated: 28V Max. 300 Ohm Min.	System Type 3: a. 28V Max. 300 Ohm Min. & 10V Max. 50 Ohm Min. return b. 28.5V Max. 300 Ohm Min. & 9V Max. 50 Ohm Min. return									
System Type 1: Single Channel Polarized Rated: 28V Max. 300 Ohm Min.														
System Type 2: Dual Channel Polarized Rated: 28V Max. 300 Ohm Min.														
System Type 3: a. 28V Max. 300 Ohm Min. & 10V Max. 50 Ohm Min. return b. 28.5V Max. 300 Ohm Min. & 9V Max. 50 Ohm Min. return														
ATEX/IECEX/UKEx	 Ex II 1 GD, (Option W) Ex ia IIC T4 Ga Ex ia IIIC T135°C Da IP65 enclosure (Option W) T _a = -40 to +80 °C  Ex II 1 G Ex ia IIC T4 Ga	Transducer Parameters <table border="1"> <tr> <td>U_{max}¹ = 28 V</td> <td>P_i³ = 0.653 W</td> </tr> <tr> <td>I_{max}² = 93 mA</td> <td>C_i⁴ = 0</td> </tr> <tr> <td></td> <td>L_i⁵ = 0</td> </tr> <tr> <td>¹V_{max} = Max Voltage</td> <td>³P_i = Max Power</td> </tr> <tr> <td>²I_{max} = Max Current</td> <td>⁴C_i = Capacitance</td> </tr> <tr> <td></td> <td>⁵L_i = Inductance</td> </tr> </table>	U _{max} ¹ = 28 V	P _i ³ = 0.653 W	I _{max} ² = 93 mA	C _i ⁴ = 0		L _i ⁵ = 0	¹ V _{max} = Max Voltage	³ P _i = Max Power	² I _{max} = Max Current	⁴ C _i = Capacitance		⁵ L _i = Inductance
U _{max} ¹ = 28 V	P _i ³ = 0.653 W													
I _{max} ² = 93 mA	C _i ⁴ = 0													
	L _i ⁵ = 0													
¹ V _{max} = Max Voltage	³ P _i = Max Power													
² I _{max} = Max Current	⁴ C _i = Capacitance													
	⁵ L _i = Inductance													
CCC/NEPSI	 Ex ia IIC T4 Ga Ex iaD 20 T135 (Option W) IP65 enclosure (Option W)  Ex ia IIC T4 Ga	Transducer Parameters <table border="1"> <tr> <td>U_{max}¹ = 28 V</td> <td>P_i³ = 0.653 W</td> </tr> <tr> <td>I_{max}² = 93 mA</td> <td>C_i⁴ = 0</td> </tr> <tr> <td></td> <td>L_i⁵ = 0</td> </tr> <tr> <td>¹V_{max} = Max Voltage</td> <td>³P_i = Max Power</td> </tr> <tr> <td>²I_{max} = Max Current</td> <td>⁴C_i = Capacitance</td> </tr> <tr> <td></td> <td>⁵L_i = Inductance</td> </tr> </table>	U _{max} ¹ = 28 V	P _i ³ = 0.653 W	I _{max} ² = 93 mA	C _i ⁴ = 0		L _i ⁵ = 0	¹ V _{max} = Max Voltage	³ P _i = Max Power	² I _{max} = Max Current	⁴ C _i = Capacitance		⁵ L _i = Inductance
U _{max} ¹ = 28 V	P _i ³ = 0.653 W													
I _{max} ² = 93 mA	C _i ⁴ = 0													
	L _i ⁵ = 0													
¹ V _{max} = Max Voltage	³ P _i = Max Power													
² I _{max} = Max Current	⁴ C _i = Capacitance													
	⁵ L _i = Inductance													

Note: Intrinsically Safe for Current Input Units Only.



Product Code

Underwriting Group:

- C = Canadian Standards (CSA)
- E = ATEX/IECEX/UKEx
- F = Factory Mutual (FM)
- M = CCC/NEPSI

Model T6000 Electro-Pneumatic I/P, E/P Transducer

Mounting Kits

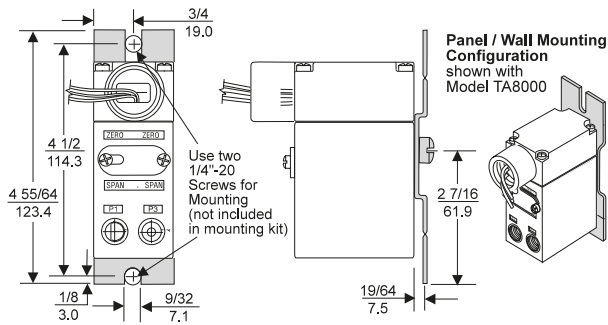

Mounting Bracket: 16799-1
(included with unit)

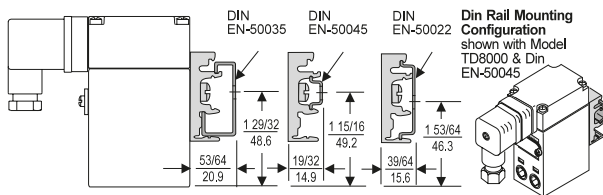

Mounting Bracket: 16893-1
(included with unit)

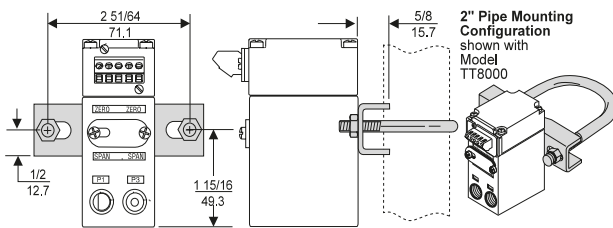

Mounting Bracket: 19254-1
(sold separately)

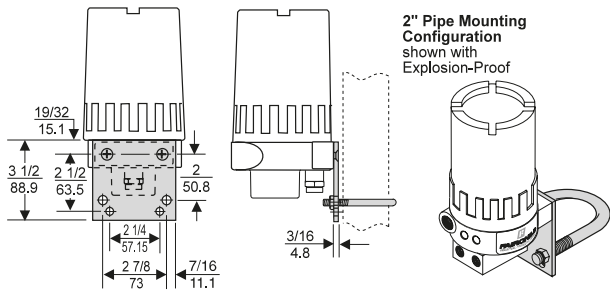

Mounting Bracket: 18187-1
(sold separately)

Product Code

T A C I 6000- 4 01 U

Electrical Connections

- A = 1/2 NPT Conduit fitting with Pigtail
- D = DIN43650 Connection
- J = Junction Box
- R = Rack Mount
- T = Terminal Block (leave blank if Explosion-Proof)

Underwriting Group

- C = Canadian Standards
- E = ATEX¹
- F = Factory Manual
- M = CCC/NEPSI

Approval Class

- XPD = Explosion-Proof¹
Dust Ignition-Proof (includes NEMA 4X/IP 65)
- I = Intrinsically Safe²
= None (leave blank)

Input

- 4 = 4-20 mA
- 3 = 10-50 mA
- 5 = 1-5 VDC
- 7 = 0-5 VDC
- 9 = 1-9 VDC
- 0 = 0-10 VDC

Output (Select appropriate psig, [BAR], or (kPa) range)

- 01 = 3-15 psig
- 02 = 3-27 psig
- 03 = 6-30 psig
- 04 = 0-30 psig
- 05 = 0-60 psig
- 06 = 0-120 psig
- 11 = [0.2-1.0 BAR]
- 12 = [0.2-1.8 BAR]
- 13 = [0.4-2.0 BAR]
- 14 = [0-2.0 BAR]
- 15 = [0-4.0 BAR]
- 16 = [0-8.0 BAR]
- 21 = (20-100 kPa)
- 22 = (20-180 kPa)
- 23 = (40-200 kPa)
- 24 = (0-200 kPa)
- 25 = (0-400 kPa)
- 26 = (0-800 kPa)

Options

- U = BSPT Thread
- W = IP65 Enclosure³

¹ Only FM available for explosionproof.

² Intrinsically Safe for Current Input Units Only.

³ Option only available with W option.



Model T6000

Electro-Pneumatic I/P, E/P Transducer

A full listing of the Rotork sales and service network is available on our website.

www.rotork.com

Rotork plc, Bath, UK
tel +44 (0)1225 733200
email mail@rotork.com

Fairchild Industrial Products
3920 West Point Blvd
Winston-Salem, NC 27103
tel +1 (336) 659-3400
email US-WS-CS@Rotork.com



Electric Actuators and Control Systems
Fluid Power Actuators and Control Systems
Gearboxes and Gear Operators
Precision Control and Indication
Projects, Services and Retrofit