

rotork[®]

Keeping the World Flowing
for Future Generations



R series

RCx-xxxAx-8.09 user manual



 **HANBAY INC.**
A rotork Brand



RCx-xxxAx-8.09

(12-24 VDC; 4-20 mA Control)

Hazardous Location (Only models RCx-BxxxAx w/ ex-proof lid engraving)

USER MANUAL

Contents

<u>INTENDED USE</u>	3
<u>MANUFACTURER DETAILS</u>	3
<u>MEANING OF SYMBOLS</u>	3
<u>INSTALLATION</u>	3
Environmental Conditions	3
Mounting	4
Grounding and Securing	4
Wiring	5
<i>Wiring for Explosion Proof Actuators</i>	5
<i>Wiring for Non-Explosion Proof Actuators</i>	6
Power Supply and Current Draw	6
Control Signal and Feedback	7
<u>GENERAL SPECIFICATIONS</u>	8
<u>OPERATION</u>	9
DIP switches	9
Controlling the Actuator	9
<i>Changing the number of turns</i>	10
Torque Settings	11
<i>Speed and Torque Details</i>	11
Signal Loss and Calibration	13
Manual Override	14
Troubleshooting	14
<u>CERTIFICATIONS</u>	15
Hazardous Location Rating (Ex)	15
Electrical Compliance (EC)	16
Electromagnetic Compatibility (EMC)	16
Dust and Water Ingress Protection (IP)	16
<u>ACTUATOR DIMENSIONS</u>	17
<u>PART NUMBER BREAKDOWN</u>	20
<u>LABEL BREAKDOWN</u>	21

INTENDED USE

Rotork R-Series actuators are intended to be used in combination with any valve to regulate the flow automatically. The output of the actuator is rotary or linear, and is paired with the valve stem to achieve the desired flow control.

MANUFACTURER DETAILS

Rotork manufactures the R-Series actuator at the following facilities:

Hanbay Inc.
135 Brunswick Blvd.
Pointe-Claire, QC H9R5N2 Canada

Fairchild Industrial Products Company
3920 West Point Blvd.
Winston Salem, NC 27103 USA

MEANING OF SYMBOLS



The exclamation point within an equilateral triangle is intended to alert the user to the presence of important operating and maintenance (servicing) instructions in the literature accompanying the product.



The Lightning Flash with arrowhead symbol within an equilateral triangle, is intended to alert the user to the presence of un-insulated "dangerous voltage" within the product enclosure that may be of sufficient magnitude to constitute a risk of shock to persons.

INSTALLATION

The safety of any system incorporating the equipment is the responsibility of the assembler of the system.

Environmental Conditions

The R-Series actuator has an IP68 rating and is recommended for outdoor use. The relative humidity of the environment has no effect on the R-Series.

The ambient temperature range for the standard R-Series is -20 to 40 °C (-4 to 104 °F).
The internal heater option shifts the temperatures to a lower range of -40 to 40 °C (-40 to 104 °F).

The standard R-Series has been approved for use at altitudes of up to 2000 m.



Mounting

The holes indicated in the image are intended for a mounting bracket. They are threaded for ¼-20 and are 0.4" deep.

Grounding and Securing

The other two visible holes are threaded 10-32, 0.50" deep, and are intended to be used to lock the lid in position (top) and as an external grounding connection (bottom) using user-supplied screws.

For detailed dimensions see p.15.

Additionally, there is a grounding connection supplied internally.

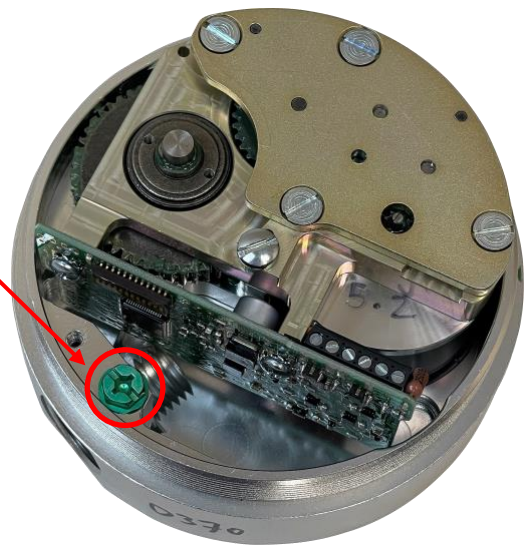

Wiring

Wiring for Explosion Proof Actuators



The **RCx-BxxAx** Explosion-Proof actuator does **not** come with a pre-installed cable, nor cable gland. A cable gland that meets site specifications for the appropriate hazardous location rating is required for installation. The cable gland and the cable for hazardous location should be installed by qualified personnel in accordance with site and local requirements.

The actuator comes standard with a 1/2" FNPT thread cable entry. See p.15 for location of 1/2" FNPT housing access. A cable with 5 wires is required; it is recommended to use 16-24 AWG for all wires.



Standards for cable gland and cable in hazardous locations:

Compliance Standards Required to be Met	Cable Types Permitted in Class I Division 1 Hazardous Locations
ANSI / UL 514B, ANSI / UL 1203, ANSI / UL 2225, C22.2	Non-Armored Extra Hard Usage Cord & TC-ER-HL
ANSI / UL 514B, ANSI / UL 1203, ANSI / UL 2225	Armored IEEE 45 & IEEE 1580 Marine Shipboard Cable
ANSI / UL 514B, ANSI / UL 1203, ANSI / UL 2225	MC-HI, ITC-HL
ANSI / UL 514B, ANSI / UL 1203, C22.2	Teck 90 (Canada Only)

* In explosion-proof models, the FNPT thread is not intended for conduit connection. Cable gland only.

Once the cable and cable gland are installed, connect the wires to the pins on the terminal block as indicated here:

Pin	Function
6	+24VDC
5	Power gnd.
4	Feedback signal (4-20 mA) *
3	Not connected
2	Isolated** input signal gnd.
1	Isolated** input signal (4-20 mA)

* "feedback" available in RCx-xxxAF version only

** "isolated" available in RCx-xxxAI and xxxAF versions only

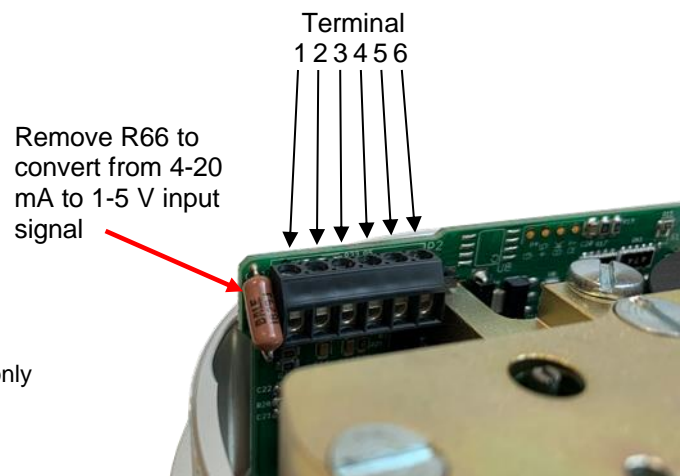

If the sensing resistor R66 is removed, we recommend placing a 10K resistor between signal and signal GND, or simply using shielded cables (for noise reduction).

Wiring for Non-Explosion Proof Actuators

The actuator comes standard with a Turck 5-position connector and a 20' cable (5x 22 AWG) with plug. Cut the cable to the length required, then connect according to the following wire color schematic.

Pins indicate the connection of the cables to the terminal block on the PCB board within the actuator. These are pre-wired at the factory for non-explosion proof actuators.

Wire color schematic for "Turck 5" cable:

Pin	Colour	DC power supply only
6	White	+24VDC
5	Black	Power gnd.
4	Grey	Feedback signal (4-20 mA) *
3		<i>Not connected</i>
2	Brown	Isolated** input signal gnd.
1	Blue	Isolated** input signal (4-20 mA)

* "feedback" available in RCx-xxxAF version only

** "isolated" available in RCx-xxxAI and xxxAF versions only



Note: Power ground must be externally connected to earth ground, or one of the case grounding screws (see INSTALLATION section) must be used to connect a grounding wire of minimum 22AWG.

Power Supply and Current Draw

The RCx-xxxAx may be connected to voltages ranging within 12-24 VDC. The DC supply to the actuator must be limited by a 4 A fuse or circuit breaker; it is recommended to have this installed near the actuator.

The current draw will range from minimum 100 mA to maximum 3 A while the actuator is active. When not moving, the actuator draws approx. 50 mA.



Note: Digital potentiometer functionality is disabled for supply voltages below 18 VDC, so the actuator position will not be retained on power-loss, on power-up the actuator will need to be re-zeroed every time.

Control Signal and Feedback

Locate the correct connection terminals/wires as shown on the previous page, then connect your input signal on positions 1 and 2 (blue and brown wires) as shown below. Feedback, if applicable is connected to position 4 (grey wire).

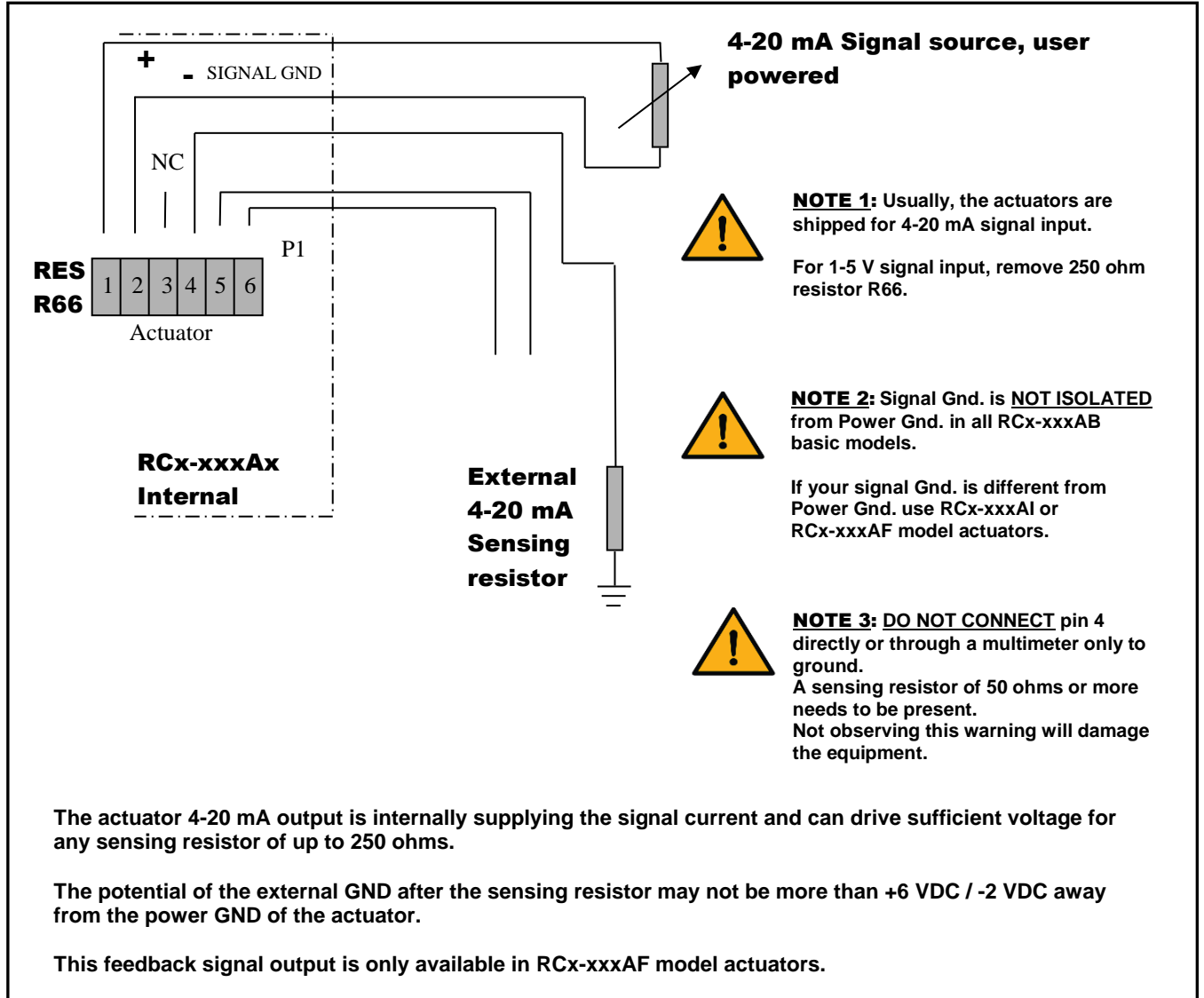

GENERAL SPECIFICATIONS

Stall protection	Electronic position and motion detection
Gears & Bearings	Metal and bronze, oiled/greased for life
External fasteners	Stainless Steel
Life Expectance	250'000 cycles in specified conditions
Motor	Brushless DC motor, computer control
Positioning precision	$\pm 0.25^\circ$
Positioning resolution	$\pm 0.15^\circ$ max.
End travel detection	By motion detection
Power setting	Adjustable
Mechanical Shock	Repeated ≤ 130 g-force, no effect Occasional ≤ 150 g-force, no effect >150 g-force not tolerated
Mechanical Vibration	Random SAE J1211, Chassis, Exterior
Thermal Shock	-20 to +60 °C (-4 to 140 °F) in 10 min.
Weight	RxJ, RxL, RxM: 980 g RxH, RxF: 1700 g
Isolated Signals (AI & AF models only)	Optical isolation min. 1000 V

OPERATION

DIP switches

The DIP switches allow you to change the settings on your actuator. To flip a switch, gently use a small flat-head screwdriver.

See the table below for DIP switch functionality.



In this example DIPs 1, 2, 5 and 12 are on.

DIP	Function
1	Speed: Choose how quickly the actuator will turn the valve. See p.11.
2	
3	Only in the ON position for actuator model RCH (with external gear stage).
4	Turns: The actuator usually ships from the factory with the recommended number of turns for the valve. However, this number can be changed. Turning on a switch will add a specific number of
5	turns to the actuator's movement.
6	
7	See p.11 for relation between positions of the DIP switches and number of turns.
8	Example: Turning on DIP 6 adds four turns, turning on DIP 8 adds one turn. If both DIP 6 and 8 are on, then the total turns of the actuator would be five.
9	Signal loss: See p.13.
10	Seating torque: Set how much torque the actuator exerts on the valve lever during the calibration
11	(finding valve seat) procedure. See p.11.
12	Direction/Calibration: Toggle switch on and off while powered to re-calibrate actuator (find valve seat). Also sets direction in which the actuator will open and close. See p.13.

Example: The RCM model actuator turns clockwise when the signal is decreased with DIP 12 in the OFF position. Putting DIP 12 in the ON position will cause counter-clockwise turning for a decrease in signal. For changes in DIP 12 position to take effect, the power to the actuator must be cycled.

Controlling the Actuator

The 4-20 mA (or 1-5 V / 1-10 V) input signal represents a total span of a number of turns.

I.e.: If you set the number of turns to 2, then a signal of 12 mA will set the actuator to exactly 1 turn from the fully closed position. 15 mA will give: $(15-4)/16=0.6875 \Rightarrow 68.75\%$ of 2 turns $\Rightarrow 1.375$ turns from closed.

Changing the number of turns

With the DIP switch settings, you can adjust anything between 1 and 31 turns to represent the full signal range of 4-20 mA. Check in the table below. (1 = “On”, 0 = “Off”).

Total Turns Dip4=0	DIP 5	DIP 6	DIP 7	DIP 8
reserved	0	0	0	0
1	0	0	0	1
2	0	0	1	0
3	0	0	1	1
4	0	1	0	0
5	0	1	0	1
6	0	1	1	0
7	0	1	1	1
8	1	0	0	0
9	1	0	0	1
10	1	0	1	0
11	1	0	1	1
12	1	1	0	0
13	1	1	0	1
14	1	1	1	0
15	1	1	1	1

For more turns, set DIP 4 to the ON position. This will add 16 turns to the number set by DIPs 5 through 8, as shown in the table.

DIP 4=0	+0 turns
DIP 4=1	+16 turns



WARNING: Be sure that the number of turns the actuator is set for is **LESS** than the number of turns for the valve. The actuator should not stop itself on a fully opened valve. It can damage the valve, and the actuator will lose its position.

Torque Settings

To accommodate different valves and other applications with different torque requirements, the actuator can be set to apply different torque on the valve stem when in the seating mode.

During normal operation, the actuator will try to reach the speed set by DIP 1 and DIP 2. It will use 100% torque to try and reach the selected speed, regardless of the positions of DIP 10 and DIP 11. Current draw is limited to 3 A regardless of settings.

Please see the box to the right and the tables below to select the power setting that is right for your application.

Seating power settings: (when operating at 24 VDC)

DIP 10	DIP 11	Power
OFF	OFF	16%
OFF	ON	33%
ON	OFF	66%
ON	ON	100%

To deal with sticking valves, at the beginning of the first reversing movement after the seating (“zeroing”) of the valve, the actuator will apply double the power set by DIP 10 and DIP 11 (up to 100% power.) This “pull out” function is always enabled.



WARNING: High power settings can supply enough torque to damage your valve. Please be cautious, especially when using the 100% power setting.



Note: 66% setting and 100% setting require voltage supply minimum values as follows:

- Supply voltage needs to be min 14 VDC for 66% setting
- Supply voltage needs to be 16 VDC for 100% setting
- When operating above 20 VDC and 66% power, Duty cycle is reduced to 50% - 25% maximum. At these levels, the electronics produce more heat which must be dissipated (depending on environmental temperature)

Speed and Torque Details

The maximum speed of the actuator can be set by using the first two positions of the DIP switch selector. As a result of this setting, the actuator will limit the maximum speed. The tables below show the time required to complete one turn.

The seating torque depends on the voltage provided in the power connection and on the seating power settings on DIP 10, 11 as shown below.

RCL-xxxAx Actuators

Speed:		
DIP 1	DIP 2	Time for 1 turn (sec)
OFF	OFF	7
OFF	ON	3
ON	OFF	2
ON	ON	1

Torque:				
DIP 10	DIP 11	Seating Torque (in-lbs)		Operating torque is 100%
		12 VDC	24 VDC	
OFF	OFF	6	12	
OFF	ON	10	20	
ON	OFF	19	38	
ON	ON	24	48	

NOTE: If actuator is RCJ-xxxAx, divide torque values by 3.
To convert in-lbs to Nm, divide by 9.

RCM-xxxAx Actuators

Speed:		
DIP 1	DIP 2	Time for 1 turn (sec)
OFF	OFF	23
OFF	ON	11
ON	OFF	7
ON	ON	4

Torque:				
DIP 10	DIP 11	Seating Torque (in-lbs)		Operating torque is 100%
		12 VDC	24 VDC	
OFF	OFF	17	35	
OFF	ON	30	60	
ON	OFF	55	115	
ON	ON	70	145	

NOTE: If actuator is RCK-xxxAx, divide torque values by 3.
To convert in-lbs to Nm, divide by 9.

RCH-xxxAx Actuators

Speed:		
DIP 1	DIP 2	Time for 1 turn (sec)
OFF	OFF	90
OFF	ON	45
ON	OFF	30
ON	ON	18

Torque:				
DIP 10	DIP 11	Seating Torque (in-lbs)		Operating torque is 100%
		12 VDC	24 VDC	
OFF	OFF	60	120	
OFF	ON	102	205	
ON	OFF	200	400	
ON	ON	248	497	

To convert in-lbs to Nm, divide by 9.

RCF-xxxAx Actuators

Speed:		
DIP 1	DIP 2	Time for 1 turn (sec)
OFF	OFF	186
OFF	ON	94
ON	OFF	56
ON	ON	38

Torque:				
DIP 10	DIP 11	Seating Torque (in-lbs)		Operating torque is 100%
		12 VDC	24 VDC	
OFF	OFF	115	230	
OFF	ON	190	380	
ON	OFF	360	720	
ON	ON	457	915	

To convert in-lbs to Nm, divide by 9.

Signal Loss and Calibration

1. **For actuators that are not connected to a UPS** (Uninterruptible Power Supply), the loss of signal will be simultaneous with power loss. Consequently, the actuator will not be able to move anywhere. In the shutdown process, the actual position is automatically saved to the internal EEPROM. [This saving of the position only happens for min. 18 VDC supplies] When power is restored, the actuator will “know” its location and will simply start to follow the signal as received.



IF YOU HAVE TO turn the actuator manually when its power is turned off, it will lose its position, and it will need to be re-zeroed (as described in sub-section 3)

2. **For actuators that are connected to a UPS** the behavior on signal loss can be set as follows:

Normal position of DIP 9: OFF

With DIP 9 in the off position, the actuator will ignore the signal if it is lost (i.e.: if the signal falls below 0.700 V or 2.80 mA) and simply remain in its current position.

Note: if the sensing resistor R66 is removed (for 1-5 V input signals), we recommend placing a 10K resistor between signal and signal GND.

Predetermined signal loss position DIP 9: ON

With DIP 9 in the on position, the actuator will move to a predetermined position when the signal is lost (i.e.: if the signal falls below 2.80 mA or 0.700 V).

Setting of the predetermined signal loss position:

- a.- turn DIP 9 to the “off” position
 - b.- re-zero the actuator by sending and holding an input signal between 2.80 and 4.16 mA (0.700 and 1.04 V) wait until the device is re-zeroed, (i.e.: valve is closed)
 - c.- by varying the input signal, move the actuator to the position that is going to be the predetermined signal loss position.
 - d.- switch DIP 9 to the “on” position. The current actuator position will be saved as the default signal loss position. (The default signal position is an absolute actuator position, not a signal value.)
3. **Re-zeroing the actuator and initiating calibration routine:**
The actuator will re-zero when the input signal is between 2.80 and 4.16 mA (0.700 and 1.04 V). It will turn clockwise until the actuator has reached the fully closed position of the valve.

If the valve is removed for any reason, the calibration routine must be initiated on the actuator manually. This is done by toggling DIP 12 (switch position, then back to the original position) while the actuator is powered. This will prevent damage to the valve.

If you need to re-zero in the opposite direction (i.e.: for pressure regulators, which typically go to the “top” fully open position at 4 mA) change the setting of DIP 12 and cycle power.
 4. **Feedback calibration: [RCx-xxxAF model actuators only]**
The current feedback will be calibrated from the factory.
To re-calibrate the feedback:
 - a.- Turn off the actuator and disconnect the feedback and input signals. If possible, remove the actuator from the valve.
 - b.- Connect the feedback signal to the signal input. Also connect the power and signal grounds.
 - c.- Power up the actuator with this “signal loop-back” setup.
 - d.- Short SP1. It will automatically run a special routine to calibrate the feedback signal to the signal input. The whole process takes about 1.5 seconds.
 - e.- turn off the power and reconnect the actuator as normal.

Manual Override

The RCx-xxxAx actuator with manual override can also be certified for hazardous locations. The additional manual override gear case and handle has no effective ignition sources and can therefore be used in all hazardous locations for which the actuator enclosure is certified for.

Operation of the manual override when the actuator is powered will be difficult as the actuator will try to maintain the valve in the position it has been commanded to.



Power should be removed if the valve is to be moved manually. If the valve is moved with the manual override when its power is turned off, it will lose its position, and it will need to be re-zeroed (as described in the Signal Loss and Calibration section).



Troubleshooting

Upon noticing a problem, your first step should almost always be to recalibrate the actuator by toggling DIP 12 while the actuator is powered. This alone can solve basic problems. See sub-section 3 above for more details.

If the actuator does not move, try following these steps:

- 1) Re-calibrate the actuator. This will move the actuator regardless of what signal it is receiving.
- 2) A sticking valve may be the problem. Remove the valve from the actuator, and re-test the actuator.
- 3) Remove power. Re-check the wiring and the power/signal apparatus. Power actuator and re-calibrate. If the problem persists, please call Rotork for technical support.

Any parts found to be defective should be examined and/or replaced by Rotork.

CERTIFICATIONS

Hazardous Location Rating (Ex)

Actuator model number: RCx-**B**xxAx

Canada:

Class I, Division 1, Groups B, C, D (T5)
Class II, Division 1, Groups E, F, G (T5)

CSA C22.2 No. 30-M1986
CSA C22.2 No. 25-17

Ambient temperature range: -50°C to +40°C

* Serial number will be engraved on lid.
Lid engraving with Canadian hazardous location certification:



USA:

Class I, Division 1, Groups B, C, D (T5)
Class II, Division 1, Groups E, F, G (T5)

UL 1203 (Edition 5.0)

Ambient temperature range: -20°C to +40°C

* Serial number will be engraved on lid.
Lid engraving with USA hazardous location certification:



International (IECEx) – available upon request:

Ex db IIB+H2 T3 Gb

IEC 60079-0:2017, 7th Edition
IEC 60079-1:2014, 7th Edition

*Serial number will be engraved on the lid.

Electrical Compliance (EC)

Canada & USA:

CSA.UL 61010-1

Europe:

EC Declaration of Conformity (CE)

UK Declaration of Conformity (UKCA)

Electromagnetic Compatibility (EMC)

United States:

FCC 47 CFR Part 15, Subpart B (Unintentional radiators), Class A

Canada:

ICES-001 Issue 5, July 2020, Class A

Europe:

EN 61326-1:2013 (Group 1, Class A; Industrial electromagnetic environment)

IEC 61000-6-2:2016

IEC 61000-6-4:2018

Dust and Water Ingress Protection (IP)

IP68, certified using standard IEC 60529:2013.

ACTUATOR DIMENSIONS

RCJ/ RCL/ RCM -xxxAx models

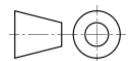
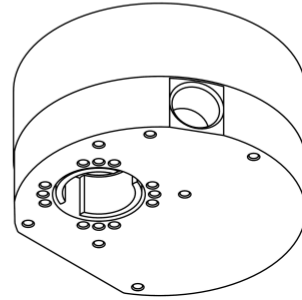
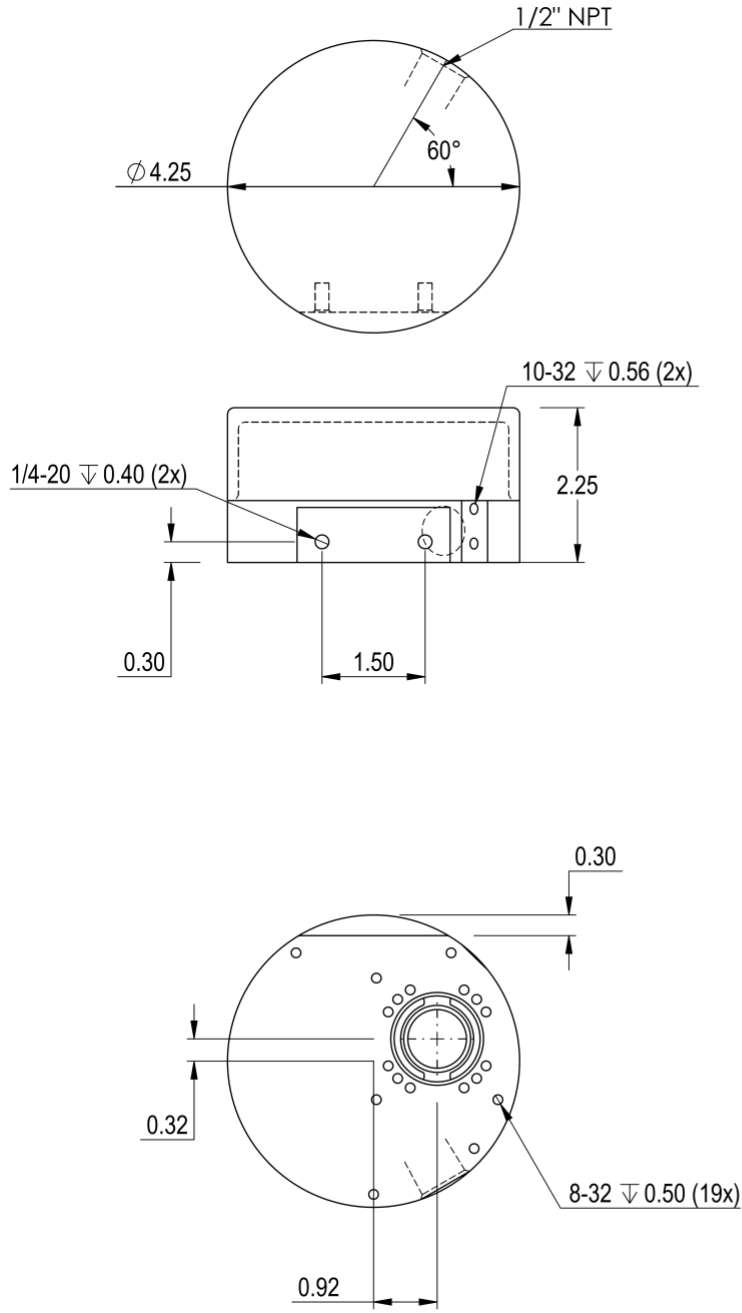

RCH-xxxAx models

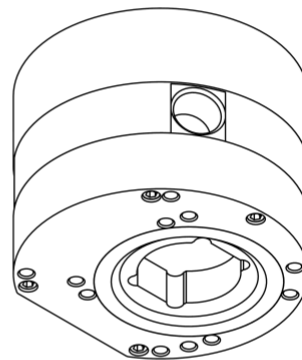
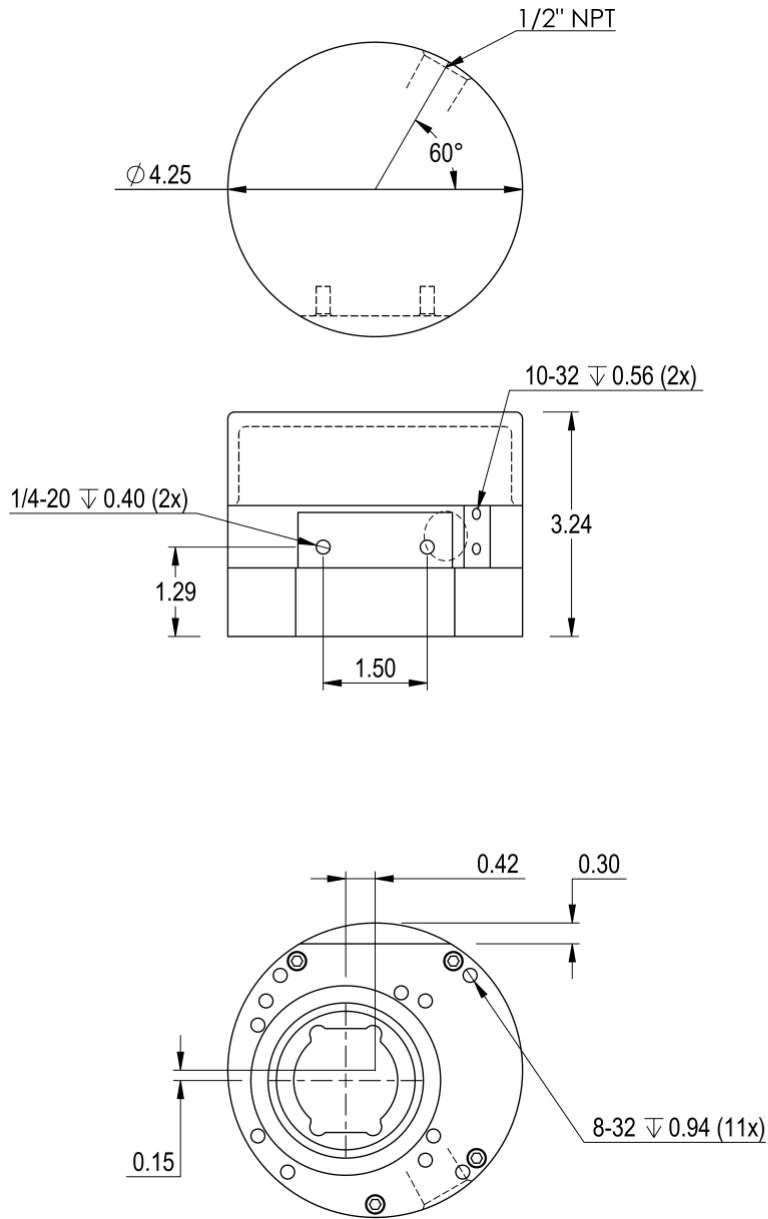

RCF-xxxAx models



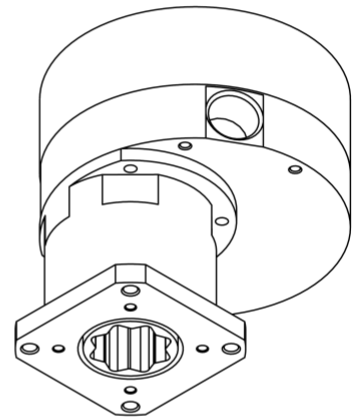
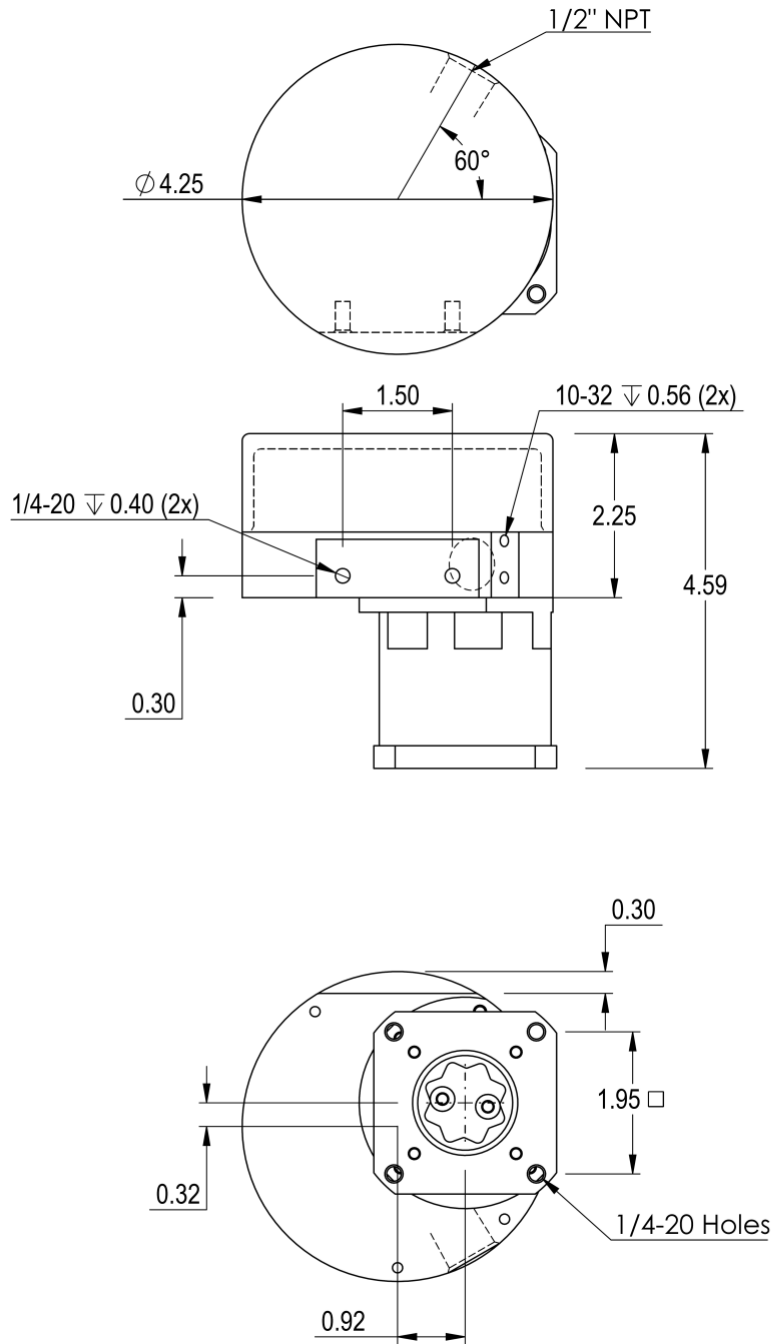

PART NUMBER BREAKDOWN

Full Part Number:

R **C** - - - **Ax** - -

Base Enclosure		Positioning		Gear Train		Special Options		Enclosure Options		Wiring		Thermal Management		PCB		Mounting Kit		Valve Part Number		
R			-		-															Valve Manufacturers Part # / CU #
R	R-Series																			0 No Valve or Mounting Kit 1 Mounting Kit, Customer Supplies Valve, does not send valve to Hanbay 2 Mounting Kit, Customer Supplies Valve, sends valve to Hanbay 3 Mounting Kit, Hanbay Provides Valve
C	Continuous																			
D	Discrete																			
J	Extra Low Torque																			
L	Low Torque																			
M	Medium Torque																			
H	High Torque (Add. Gear Stage)																			
F	F-Gear Stage (Add. Gear Stage)																			
AB	Analog Signal Board																			
AF	Analog Signal Board Isolated with Feedback																			
AI	Analog Signal Board Isolated Input																			
AS	Modbus Control with Feedback																			
DC24	Continuous TTL Board, 0V input / 24V feedback signal																			
DC5	Continuous TTL Board, 0V Input / 5V feedback signal																			
DT24	Discrete TTL Board, 0V Input / 24V feedback signal																			
DT5	Discrete TTL Board, 0V Input / 5V feedback signal																			
PT	Propane Board, Limit Switches, Thermal Cut Off																			
0	No Option																			
H	Internal Heater																			
0	Cable Gland (Specify Cable & length at added cost) *If the actuator has an ex-proof enclosure, 0 indicates an NPT plug																			
4	Custom Dual Gauge Cable, 10ft.																			
5	TURCK 5 Position Connector w. 20' Cable and Plug																			
6	TURCK 6 Position Connector w. 20' Cable and Plug																			
7	TURCK 5 Position Connector Only																			
9	TURCK 6 Position Connector Only																			
0	Standard Anodised Alloy Enclosure																			
B	Hazardous Locations-Rated																			
S	Stainless Steel Enclosure																			
E	Stainless Steel Hazardous Locations-Rated																			
0	No Special Options																			
AC	110-240 VAC Power Supply																			
B	Battery Backup																			
BS	Bottom Stop																			
G	G-Stage Gate Valve (with MCM or MCL)																			
HT	High Temperature Mounting Kit																			
L1	Linear 16 TPI																			
L2	Linear 8 TPI																			
M	Manual Override																			
PM	Position Indicator (Multi-turn)																			
QR	Quick Release Mounting Kit																			
RS	Reverse Spring Return																			
S	Spring Return																			

LABEL BREAKDOWN

Firmware Version

AF-1.05 } MM = Multiturn
 AB-1.05 } MML = Multiturn Low Torque
 AS-1.05 } MMUL = Multiturn Extra Low Torque
 QM = Quarter turn
 QM97 = Quarter turn 97°
 DT-2.01
 DC-2.01
 M-Dx V2.34

Actuator Supply Voltage

12-24 VDC @ 3.0 A or
 110-240 VAC, 50/60 Hz @ 1.5 A

Actuator Series

M-Series or R-Series

Circuit Board Version

Ax-8.09
 Dx-10.41
 Px-10.3

rotork
HANBAY

www.hanbayinc.com
 (336) 659 3400
 NC, 27103

R-Series 12-24 VDC 3.0A

RCM-050AB

POWER OFF UNIT BEFORE REMOVING COVER

Made in USA

S/N: 19103201-01

Ax-8.09
 AB-1.05MM

User Manual:



Actuator Part Number

Refer to part number breakdown for available options.

QR Code

Scan this QR code for a direct link to the user manual for your unit!

Actuator Serial Number

This serial number is unique for each individual unit and is directly tied to your order/invoice number.

As part of a process of on-going product development, Rotork reserves the right to amend and change specifications without prior notice. Published data may be subject to change. For the very latest version release, visit our website at www.rotork.com
 The name Rotork is a registered trademark. Rotork recognises all registered trademarks. Published and produced in the UK by Rotork. POLJB0424