

rotork[®]

Keeping the World Flowing
for Future Generations

GH range

Hydraulic actuator
Single-acting and double-acting configuration

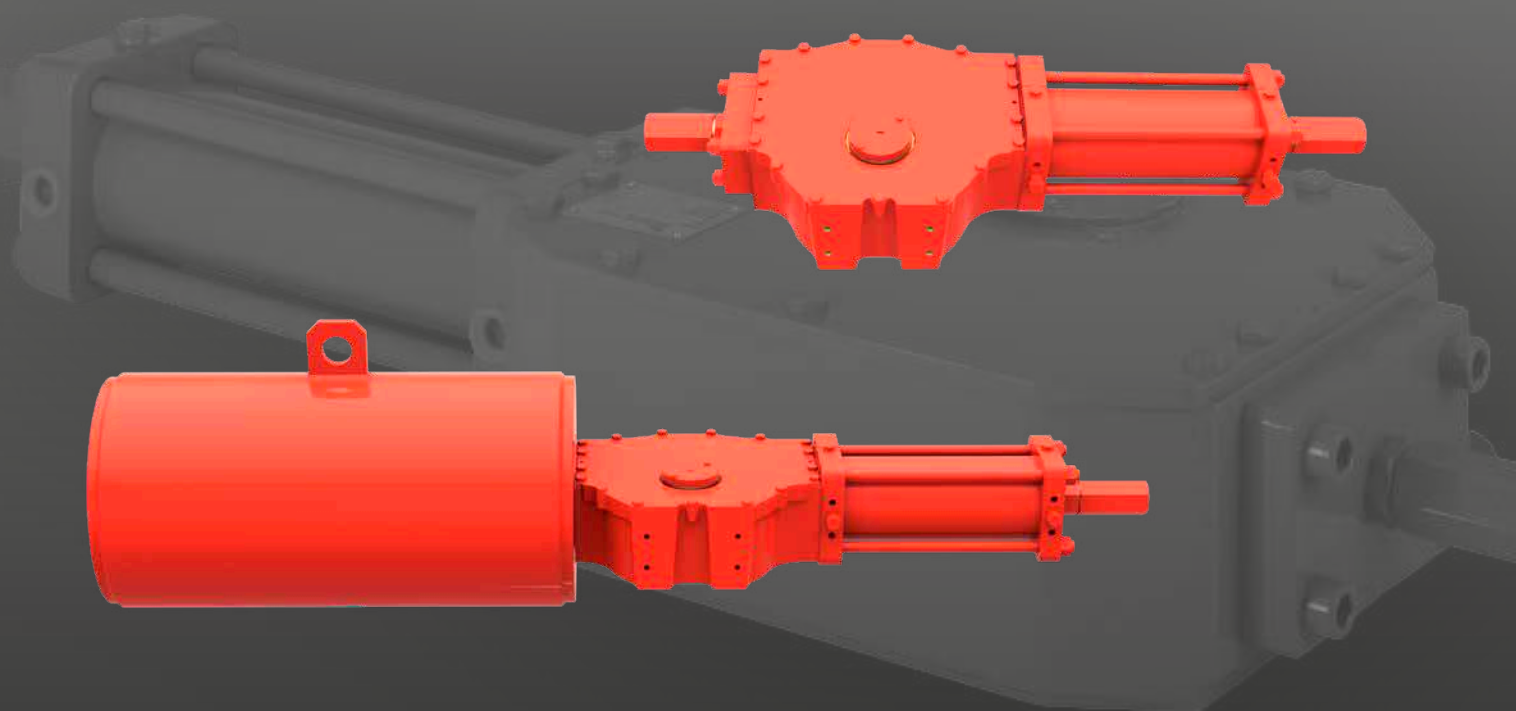

Installation, commissioning and maintenance manual

Contents

Section	Page	Section	Page
1. Introduction	3	11. Removal from valve	11
2. Standards and regulations	3	12. Operation	12
3. General information	4	12.1 Description	12
4. Health and safety	5	12.2 Operating description	14
4.1 Residual risks	5	12.3 Manual override	14
4.2 Thermal risks	5	12.4 Angular stroke setting	15
4.3 Noise	5	12.5 Hydraulic power supply	17
4.4 Health risks	5	12.6 Hydraulic connections	17
4.5 Mechanical risks	5	12.7 Electrical connections	18
5. Labels and nameplates	5	12.8 Start up	18
6. Operating limits	6	13. Dismantling and disposal	19
6.1 Allowed fluid types	6	14. Rotork sales and service	19
6.2 Expected lifetime	6	15. Troubleshooting	20
6.3 Tightening torque chart	6	16. Periodic maintenance	21
7. Handling and lifting	7	17. Part list	44
7.1 Lifting recommendations	7	18. Grease and hydraulic oil specification	52
7.2 Lifting instructions	7	18.1 Grease	52
8. Storage	9	18.2 Hydraulic oil	53
9. Long term storage	9		
10. Installation on valve and earthing	10		
10.1 Preliminary actions	10		
10.2 Instructions	10		



Single-acting actuator with welded body

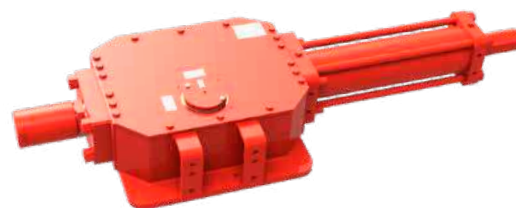

Double-acting actuator with welded body

This manual contains important safety information. Please ensure it is thoroughly read and understood before installing, operating or maintaining the equipment.

Rotork reserves the right to modify, amend and improve this manual without notice.

Rotork is not responsible for damage or injury caused by the failure to observe the instructions contained herein.

1. Introduction

This manual covers maintenance aspects and instructions specific to the GH range of actuators. General information on Rotork actuators are described in the user manual, delivered separately.

In this manual, warning indications are represented by icons, according to ISO 7010 safety signs:



Generic danger



Hand crush/pinch point



Electrocution



Explosive material

Customer service

For technical assistance, please contact Rotork customer service:

E-mail: rfs.international@rotork.com

Rotork, Via Padre Jacques Hamel, 138B, Porcari, Lucca, 55016, IT. Tel: +39 0583-222-1

Rotork plc, Brassmill Lane, Bath, UK. Tel +44 (0)1225 733200

2. Standards and regulations

Actuators destined for European member states and the United Kingdom have been designed, built and tested according to the quality control system, in compliance with the EN ISO 9001:2015 standard and with the following regulations/directive.

- 2006/42/EC: Machinery Directive (MD)
- S.I. 2008 No. 1597: The Supply of Machinery (Safety) Regulations 2008
- 2014/68/EU: Pressure Equipment Directive (PED)
- S.I. 2016 No.1105: Pressure Equipment (Safety) Regulations 2016 (PE(S)R)
- 2014/34/EU: Directive for safety equipment and systems to be used in potentially explosive atmospheres (EX)
- S.I. 2016 No. 1107: The Equipment and Protective Systems Intended for Use in Potentially Explosive Atmospheres Regulations 2016
- 2014/30/EU: Electromagnetic Compatibility Directive (EMC)
- S.I. 2016 No. 1091: Electromagnetic Compatibility Regulations 2016
- BS EN ISO 12100: Machinery Safety Directive
- BS EN 60079-14: Explosive atmospheres - Part 14: Electrical installations design, selection and erection
- BS EN 1127-1: Explosive atmospheres - Explosion prevention and protection - Basic concepts and methodology
- BS EN ISO 80079-36: Non Electrical equipment for explosive atmospheres - Basic methods and requirements
- BS EN ISO 80079-37: Non-electrical equipment for explosive atmospheres - Non-electrical type of protection construction safety "c", control of ignition "b", liquid immersion "k"
- IEC 60079-46: Explosive atmospheres - Part 46: Equipment assemblies
- BS EN ISO 7010: Safety Signals
- BS EN 13445: Unfired Pressure Vessel

3. General information

This manual is produced to enable a competent user to install, operate and maintain the Rotork GH actuator single- and double-acting (GH/S and GH/D).

The mechanical installation must be carried out as outlined in this manual and in accordance with any relevant national standard codes of practice.

Maintenance and operation must be carried out in accordance with the National Legislation and Statutory Provisions relating to the safe use of this equipment, applicable to the site of installation.

Any inspection or repair in a hazardous area must not be undertaken unless it conforms to National Legislation and Statutory Provisions relating to the specific hazardous area.

Only Rotork-approved replacement parts should be used. Under no circumstances should any modification or alteration be carried out on the equipment, as this could invalidate the conditions under which its certification was granted.

Only trained and experienced operators can install, maintain and repair Rotork actuators. Work undertaken must be carried out in accordance with instructions in this manual. The user and those persons working on this equipment must be familiar with their responsibilities under any statutory provisions relating to the health and safety of their workplace.

Operators must always wear appropriate Personal Protective Equipment (PPE) in line with the existing plant regulations.

Appropriate usage

Rotork GH range actuators have been specifically developed to automate quarter-turn valves, such as ball valves, butterfly valves or plug valves installed on pipelines for oil & gas transport and distribution.

⚠ Improper use can damage the equipment or cause dangerous situations for health and safety. Rotork declines any responsibility for damage to people and/or objects resulting from the use of the equipment for applications different from those described in the present manual.

⚠ Hazardous area usage: Only use devices approved for hazardous area use. These devices will have an EX type label fixed to them. Before installation and operation in a potentially explosive atmosphere, read and follow the information and instructions on the EX label and any additional EX instructions in the documentation received with the device.

IECEX certification

The IECEx EPS 24.0085X Certificate of Conformity (CoC) only covers non-electrical actuators described here. Any kind of assembly created by the end user or electrical accessories are not covered by this CoC.

The end user must follow special conditions for safe use detailed in document PUB010-046.

IECEX marking of GP actuators is as follow:

Ex h IIC T5 Gb
Ex h IIIC T100°C Db
Tambient down to -40°C, up to +100°C

Please refer to the actuator IECEx nameplate:

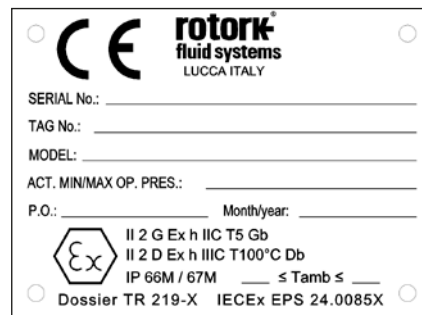

Fig 3.1 Actuator IECEx label

4. Health and safety

Before installing the equipment, verify it is suitable for the intended application. If unsure consult Rotork.

4.1 Residual risks

Residual risks resulting from equipment risk evaluation performed by Rotork.

4.2 Thermal risks

Risk Hot/cold surface during normal operation (RES_01).
Preventive measures Operators should wear protective gloves.

4.3 Noise

Risk Noise >85 dB during operation (RES_05).
Preventive measures Operators must wear ear protections. Operators must not stand near the equipment during operation.

4.4 Health risks

Risk Pressurised fluid ejection during normal operation (RES_02).
Preventive measures All fittings must be properly sealed. All fixing clamps must be correctly tightened and sealed.
Risk Risk of intoxication (according to the type of medium utilised) (RES_06).
Preventive measures Operators must use PPE and any other equipment (breathing apparatus) based on the type of supply medium.

4.5 Mechanical risks

Risk Uncontrolled movement (remote operation) (RES_03). (This risk is applicable only for actuators provided with control panel).
Preventive measures Ensure that the actuator cannot be operated remotely. Prior to starting, remove the hydraulic supply, vent all pressure vessels, and remove electrical power.
Risk Presence of moving parts (centre body, valve adapter) (RES_04).
Preventive measures Do not perform start-up or test the actuator if the cylinder tube is removed.
Risk Loss of stability with possible parts projection (RES_08).
Preventive measures Do not disassemble the actuator in case of malfunctioning. Follow instructions in the present manual and contact Rotork.
Preventive measures Foresee periodic maintenance procedure to verify tightening.
Risk Presence of potential energy (RES_10) during dismantling.
Preventive measures Do not disassemble the actuator during dismantling. Follow instructions in the present manual and contact Rotork.

5. Labels and nameplates

The following label is applied externally to the actuator:

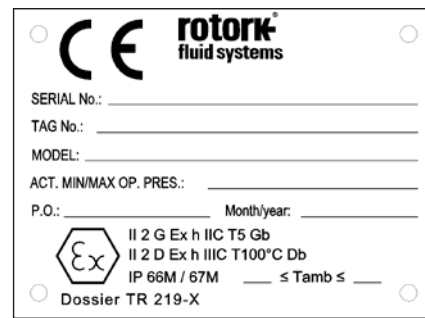

Fig 5.1 Actuator ATEX label

EX type of protection: constructional safety "c".

T5 temperature class is provided even if the actuator has no internal heat source. The maximum actuator temperature is near the environmental or exercise fluid temperature, whichever is the greater. The normal operating temperature range is -30 to +100 °C (-22 to +212 °F). The temperature range is specified within the project-specific technical documentation. Special applications out of the normal range are available upon request.

EX plate does not indicate the maximum environmental and/or exercise fluid temperature; this information is reported within the project-specific technical documentation.

For CE (PED) marked actuator the following label is also used:

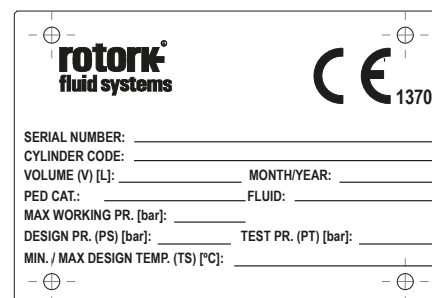

Fig 5.2 Actuator PED label

Label removal is not allowed.

6. Operating limits

Temperature: -30 to +100 °C (-22 to +212 °F) for standard applications, with NBR seals.
 -20 to +100 °C (-4 to +212 °F) for PED applications, with NBR or FKM seals.
 -40 to +100 °C (-40 to +212 °F) for low temperature applications, PED or not, with fluorosilicone seals.
 -60 to +100 °C (-76 to +212 °F) for ultra-low temperature applications, with fluorosilicone seals (ultra-low temperature range is not IECEx certified).

Design pressure: Up to 207 barg. Other design pressure options, available upon request.

Operating pressure: Up to design pressure.

⚠ Do not use the equipment outside its operating limits. Verify the operating limits on the nameplate.

Prevent external surface temperature to reach the ignition point in potentially explosive environments.

The actuator surface temperature is strictly dependent on the temperature of the process fluid used and by the irradiation's conditions. The end-user must check the surface temperature of the assembly, so that this cannot go over the minimum gas ignition's temperature, which classifies the area with the explosion's risk.

Dust and debris accumulated on the actuator will slow down its cooling and contribute to the increase of its external temperature.

⚠ Do not use the actuator in presence of naked flames.

6.1 Allowed fluid types

GH actuators are designed to be operated with hydraulic oil ISO 4406 class 17/15/12.

6.2 Expected lifetime

The expected lifetime is at least 25 years, in normal service conditions and with planned maintenance.

6.3 Tightening torque chart

RECOMMENDED TIGHTENING TORQUE (Class 8.8 bolts)		
Bolt size	Nm	lbf.ft
M6	8.5	6
M8	20	15
M10	40	30
M12	55	40
M14	110	81
M16	220	162
M20	430	317
M22	425	313
M24	585	431
M27	785	579
M30	1250	921
M33	1400	1030
M36	1750	1290
M48	5000	3688
M64	9200	6786

⚠ This tightening torque table is not applicable to Section 10.2. When installing actuator on the valve, tighten bolts or nuts of the connecting stud bolts to the correct torque, in accordance with the size and material characteristics of the bolts installed by the customer.

7. Handling and lifting

⚠ Only trained and experienced personnel should handle/lift the actuator.

The actuator is supplied packed on pallets suitable for normal handling.

⚠ Handle the actuator with care. Never stack pallets.

7.1 Lifting recommendations

- The lifting device and the sling must be suitably rated for the actuator weight and dimensions
- Do not use damaged sling(s)
- The sling must not be shortened with knots or bolts or any other makeshift device
- For lifting purposes, use only suitable lifting tools
- Do not drill holes, weld eye bolts or add any other type of lifting device on the actuator external surface
- Do not lift the actuator and valve combination with the actuator lifting lugs
- Every assembly must be estimated separately for a safe and correct lifting
- Avoid pulls or abrupt movements during lifting. Avoid pushing the load
- During lifting operations, do not handle the slings and/or the actuator

⚠ Do not step underneath suspended load.

7.2 Lifting instructions

NOTE: Indication of weight, centre of gravity, lifting points are reported within specific project documentation.

For non-horizontal actuator orientation, please consult project specific documentation before lifting.

- Prior to lifting the actuator, remove electrical power and vent all pressure vessels (if present)
- In case of single-acting actuator, hook the chain sling and textile sling on the lifting lugs, as shown in Fig 7.1
- In case of double-acting actuator, hook a double textile sling on the lifting lug on the hydraulic cylinder and a textile sling on the centre body closure flange as shown in Fig 7.2

⚠ The actuator must remain horizontal; balance the load. Use only main lifting lugs. Do not use lifting lugs with through hole smaller than 25 mm.

- Angle β must be between 0° and 45° as shown below.

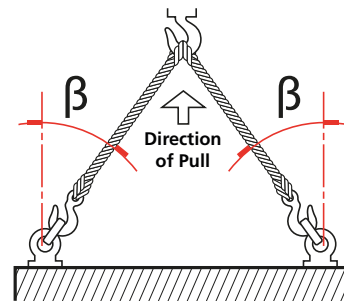

Fig 7.1 Lifting (single-acting actuator up to size 161)

7. Handling and lifting

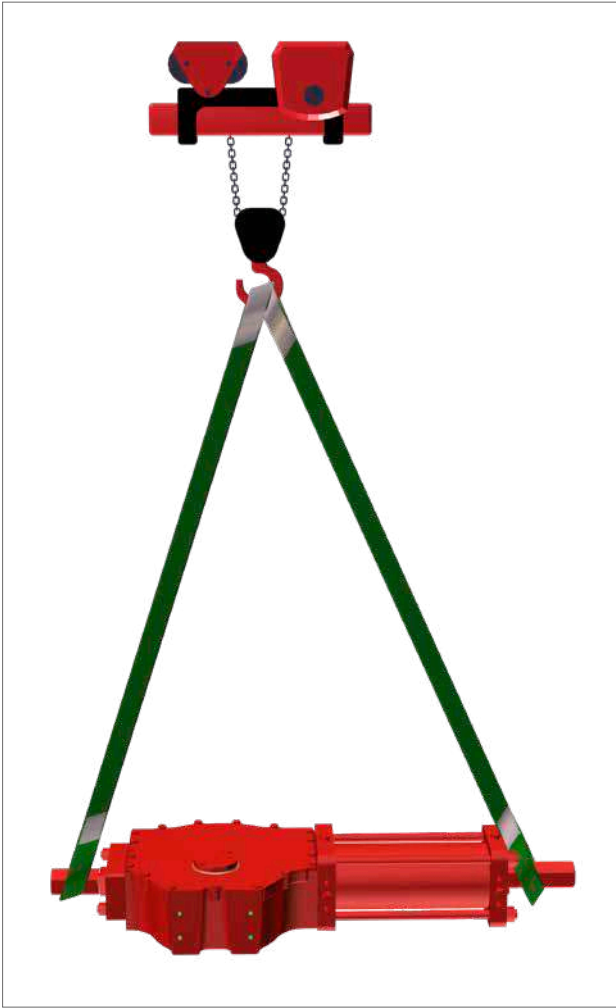

Fig 7.2 Lifting (double-acting actuator up to size 161)



Fig 7.3 Lifting (single-acting actuator size 200 - 350)



Fig 7.4 Lifting (double-acting actuator size 200 - 350)

8. Storage

Rotork actuators have been fully tested before leaving the factory.

In order to keep the actuator in good condition until installation, at least the following measures are recommended:

- Check presence and assembling of dust plugs
- Store in a dry, well-aired place. Avoid long-term direct exposure to sunlight
- Keep the actuator on shipping pallet until installation

⚠ Never put the actuator directly on the ground.

- Actuator must be positioned with the centre body cover upwards
- Protect the valve coupling area (adapter flange and coupling joint, etc.) with rust preventive oil e.g. Mobilarma LT or equivalent
- Protect against weather action, covering the actuators with appropriate polyethylene sheets
- Check the actuator condition every six months and verify the above protection measures remain in place

⚠ Remove packaging only at the installation time.

⚠ Actuator vent ports must be protected with polyethylene sheet to prevent water ingress during storage.

9. Long term storage

If long term storage is necessary, further operations must be carried out to maintain the actuator in a good working condition:

- Replace the plastic plugs with metal plugs
- Store in a dry, well-aired place. Avoid long-term direct exposure to sunlight
- Stroke the actuator every 12 months:
 - Cycle the actuator (using filtered, dehydrated air) to the working pressure indicated on the name plate
 - Cycle the actuator with all the existing controls (i.e. two complete strokes - one open, one closed) at least five times
 - Cycle the actuator fitted with the mechanical manual override or hydraulic manual override by means of the override for four complete strokes
- Disconnect the hydraulic and electric (if present) supply from the actuator, and carefully close all the threaded connections of the actuator
- Remove electrical components covers (if present) to ensure control terminals are clean and free from oxidation and humidity. Reassemble the covers
- In case of storage for over 12 months prior to installation, it is recommended to operate the actuator to verify correct operation

10. Installation on valve and earthing

Before proceeding, read and understand the health and safety information.

NOTE: The valve must be properly secured prior to performing the following operations according to instructions provided by the valve's manufacturer.

⚠️ Prior to performing any operations check the operating drawings and TAG numbers.

Consult Rotork for any additional information.

10.1 Preliminary actions

⚠️ Verify the EX classification of the actuator is compatible with the plant zoning. Refer to the actuator nameplate. The end user shall guarantee the valve earthing and the equal voltage potential between the valve and the actuator.

- The centreline of the cylinder is usually aligned to the centreline of the associated pipework
- Ensure all fasteners are adequately tightened, to avoid loosening during operation, considering the vibrations induced by the dynamics of the pipeline
- Piping used to provide power to the actuator must be free from contaminants and debris. Ensure tubing runs are adequately fastened and supported to minimise repetitive stress induced the dynamics of the pipeline. Ensure there are no leaks from any gas connections. Tighten as required

10.2 Instructions

The actuator assembly on valve can be performed by:

- Mounting directly using the actuator housing flange with threaded holes
- Using an adapter and a coupling joint between the actuator and the valve

The assembly position of the actuator must be in accordance with the actuator design, plant requirements and the valve model.

To assemble the actuator onto the valve, proceed as follows:

- Verify the coupling dimensions of the valve flange and stem; they must meet the actuator coupling dimensions (see document PUB083-001)
- Actuator is supplied in the fail position (for single-acting). Set the valve in the right position per the actuator fail position. Check the position of the actuator by means of the position indicator on the centre body or on the limit switch box (if present)
- Clean the valve and actuator coupling flanges, removing anything that might prevent electrical connection and adherence to the actuator flange interface: grease and paint residuals must be completely removed, if present.

- Inspect, clean and apply grease on the coupling hole (valve side of coupling joint)
- Lubricate the valve stem with oil or grease, to facilitate assembling
- Lift the actuator according to handling and lifting instructions (Section 7)
- If possible, place the valve stem in a vertical position to facilitate assembling – in this case the actuator must be lifted while the coupling flange is kept in the horizontal position
- If the assembly is done using an adapter and a coupling joint, assemble the coupling joint onto the valve stem before proceeding with the assembly of the actuator
- Do not exert any force while lowering the actuator onto the valve

Installation must be performed by qualified personnel.

⚠️ Hands must be kept away from the coupling area.

- Clean and degrease the coupling bolts, stud bolts, nuts and the threads on actuator body flange. Apply a thin layer of thread sealing product (Loxal 55.03 or equivalent Loctite 243) on threaded connection and on power pins, if present, to preserve actuator ingress protection level
- Fix the actuator to the valve by means of threaded connections (bolts, stud bolts and nuts)
- Tighten bolts or nuts of the connecting stud bolts to the correct torque, in accordance with the size and material characteristics of the bolts installed by the customer

⚠️ Support the actuator until fully installed and fixing bolts are correctly tightened.

⚠️ Attention: Do not pressurise the actuator/valve adapter.

- Check for possible damage to the paint-work and repair if necessary, according to painting specification

⚠️ Attention: End user should verify the electrical correctness of coupling, performing a standard continuity test between actuator and valve.

11. Removal from valve

The end user is in charge of removing the actuator from the valve.

⚠ Removal shall be performed only by qualified staff, wearing/using appropriate personal protection devices.

⚠ Do not remove the actuator if the valve is blocked in the intermediate position. Contact Rotork customer service.

To disassemble the actuator from the valve, proceed as follows:

- Cut off electrical power supply
- Cut off pneumatic/hydraulic supply
- Release any pressure from the control group
- Remove the supply pipes from the actuator
- Remove control and signal lines from electric components (if any)
- Sling the actuator according to handling and lifting instructions (Section 7)
- Unscrew bolts or nuts from the stud bolts fixing the actuator to the valve
- Lift and remove the actuator from the valve

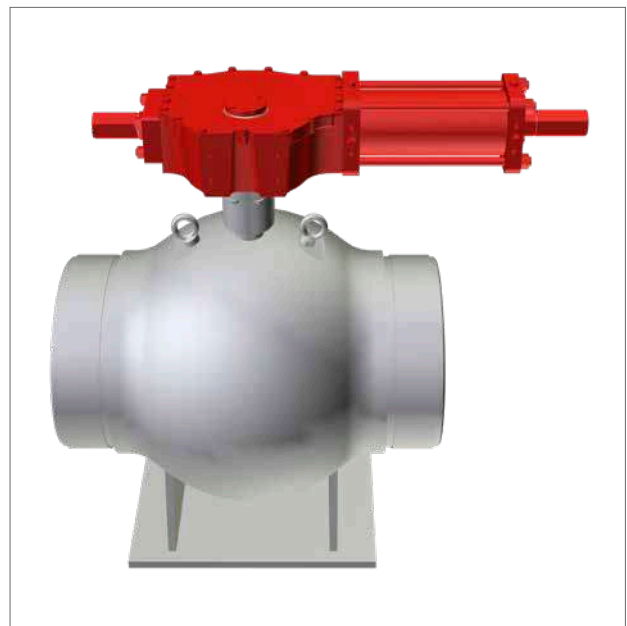
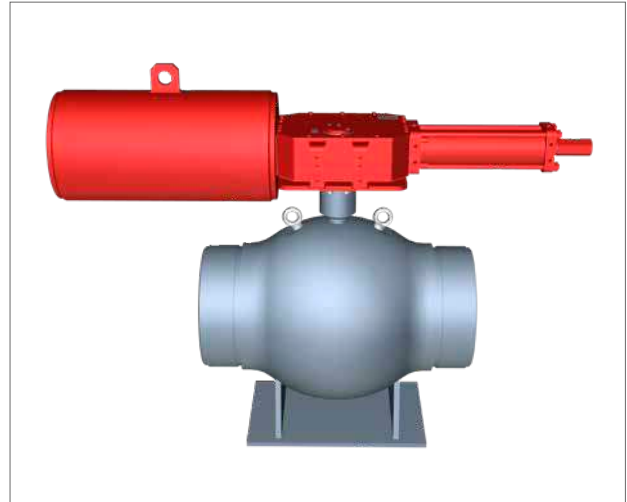

Fig 11.1 Actuator/valve assembling example

12. Operation

The following instructions must be followed and integrated into the end user safety programme when installing and using Rotork products. Read and save all instructions prior to installing, operating and servicing this product.

Follow all warnings, cautions and instructions marked on and supplied with the product.

Install equipment as specified in Rotork installation instructions and as per applicable local and national codes of practice. Connect all products to the proper pipeline gas sources.

When replacement parts are required, ensure that the qualified service technician uses only replacement parts specified by Rotork.

Substitutions will invalidate any hazardous area certification and may result in fire, electrical shock, other hazards or improper operation.

12.1 Description

The GH/S series actuators are hydraulic single-acting, spring-return actuators specifically designed to provide efficiency and reliability in heavy duty services.

GH/S actuators can be assembled in a "spring to open" or in a "spring to close" version and can be fitted with an emergency manual override suitable to operate the actuator in the event of fluid supply failure.

Main components of a GH/S actuator are:

- A **scotch-yoke mechanism**, which transforms the linear movement of the hydraulic cylinder into a rotary movement suitable for operating quarter-turn valves, such as ball valves, butterfly valves or plug valves. It is available in both "symmetric" and "canted" execution to meet application specific valve torque demand requirements.

The scotch-yoke mechanism is situated in a perfectly sealed housing, made of welded carbon steel or in cast iron, acting as a protection against corrosion and that guarantees safety of personnel during the operations.

A chromium-plated guide bar is suitable for supporting the transverse forces and ensuring the correct alignment of the piston rod. The chromium plating prevents corrosion and minimises sliding friction.

Sliding blocks and yoke bushings are made of bronze to reduce friction and to guarantee a long working life.

- A **hydraulic cylinder**, made of carbon steel.

The cylinder tube is nickel-plated internally by electrolysis, to assure the perfect dynamic seal, corrosion resistance and low friction.

The piston is made of carbon steel. The dynamic piston seal further reduces friction and avoids stick-slip effect even after prolonged periods without operation. The sliding ring made of bronze alloy guides the piston in the cylinder and ensure a good radial loading capacity.

A chromium plated piston rod ensures a perfectly dynamic seal, corrosion resistance and low friction.

- The **spring cartridge** (only for single-acting actuator), consisting of a welded container containing a frame assembled spring package that prohibits the spring from extending beyond a pre-set length.
- Two mechanical **stop bolts** to enable the adjustment of valve angular stroke.
- A **mechanical visual position indicator** directly connected to the valve stem that shows the position of the valve all along the actuator stroke.

Upon request, GH series actuators can be equipped with additional accessories (limit switches box, positioner, position transmitter, control panel, etc.)

- If a bracket or an accessory (limit switch box, positioner, etc.) has to be assembled to actuator, clean and degrease the coupling bolts, stud bolts, nuts and the threads on actuator body cover. Apply a thin layer of thread sealing product (Loxal 55.03 or equivalent Loctite 243) on threaded connection, to preserve actuator ingress protection level.

Use only control devices supplied by Rotork.

⚠ Installation of any accessory on the bare actuator must preserve the actuator ingress protection level.

⚠ Installation must be performed according to IEC 60079-14 and the end user must follow special conditions for safe use detailed in document PUB010-046.

⚠ The IECEx EPS 24.0085X Certificate of Conformity (CoC) only covers non-electrical actuators described here. Any kind of assembly created by the end user or electrical accessories are not covered by this CoC.

The end user must follow special conditions for safe use detailed in document PUB010-046.

12. Operation

The main components of GH/S actuators are shown in Fig 12.1 and Fig 12.2.

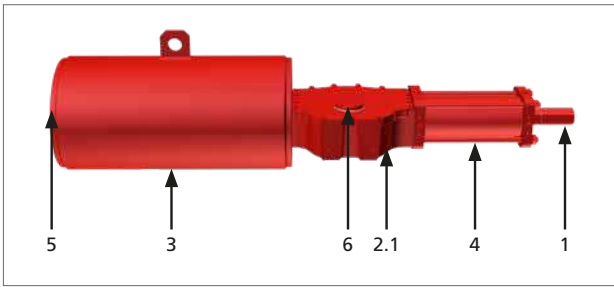

Fig 12.1 GH/S (cast body) main components

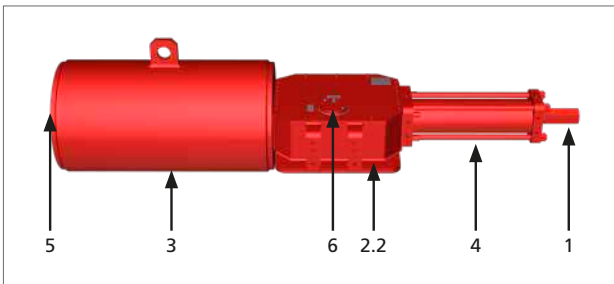

Fig 12.2 GH/S (welded body) main components

Table 1: GH/S Parts list

IT	DESCRIPTION	QTY
1	Mechanical stop bolt	1
2.1	Centre body (cast iron)	1
2.2	Centre body (welded)	1
3	Spring cartridge	1
4	Cylinder tube	1
5	Mechanical stop bolt	1
6	Mechanical visual indicator	1

The GH/D series actuators are hydraulic double-acting actuators specifically designed to provide efficiency and reliability in heavy duty services.

Actuator general features are the same as the single-acting version, except the spring canister that is replaced by the centre body closure group.

Main components of a GH double-acting actuator are:

- A **scotch-yoke mechanism**, which transforms the linear movement of the hydraulic cylinder into a rotary movement suitable for operating quarter-turn valves, such as ball valves, butterfly valves or plug valves. It is available in both "symmetric" and "canted" execution to meet application specific valve torque demand requirements.

The scotch-yoke mechanism is situated in a perfectly sealed housing, made of welded carbon steel or in cast iron, acting as a protection against corrosion and that guarantees safety of personnel during the operations.

A chromium-plated guide bar is suitable for supporting the transverse forces and ensuring the correct alignment of the piston rod. The chromium plating prevents corrosion and minimises sliding friction.

Sliding blocks and yoke bushings are made of bronze to reduce friction and to guarantee a long working life.

- A **hydraulic cylinder**, made of carbon steel.

The cylinder tube is nickel-plated internally by electrolysis, to assure the perfect dynamic seal, corrosion resistance and low friction.

The piston is made of carbon steel. The dynamic piston seal further reduces friction and avoids stick-slip effect even after prolonged periods without operation. The sliding ring made of bronze alloy guides the piston in the cylinder and ensure a good radial loading capacity.

A chromium-plated piston rod ensures a perfectly dynamic seal, corrosion resistance and low friction.

- Two mechanical **stop bolts** to enable the adjustment of valve angular stroke.
- A **mechanical visual position indicator** directly connected to the valve stem that shows the position of the valve all along the actuator stroke.

12. Operation

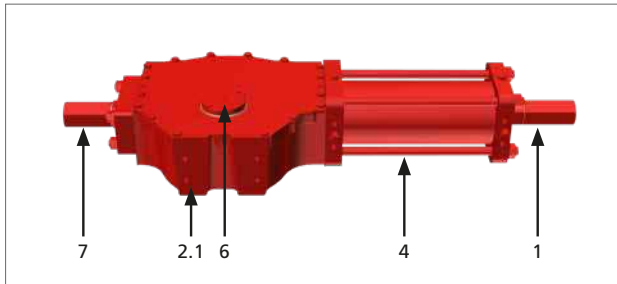

Fig 12.3 GHID (cast body) main components

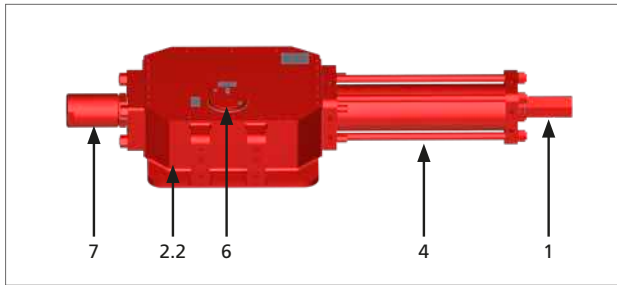

Fig 12.4 GHID (welded body) main components

Table 2: GHID Parts list

IT	DESCRIPTION	QTY
1	Mechanical stop bolt	1
2.1	Centre body (cast iron)	1
2.2	Centre body (welded)	1
4	Cylinder tube	1
6	Mechanical visual indicator	1
7	Centre body closure flange	1

12.2 Operating description

Please refer to the operating diagram supplied for the specific actuator.

In case of use of GH/D actuators in SIL applications the system integrator must fulfil all requirements reported in Section 11.2.11 of standard IEC61511-1.

⚠ Do not use the actuator outside 90° ±5° operating range.

12.3 Manual override

The GH series can be fitted with an emergency manual override suitable to operate the actuator in the event of fluid supply failure.

This device is of hydraulic type, using a hydraulic hand pump.

⚠ A maximum operating time of the manual override of 24 hours, for maintenance or testing, is recommended.

Note: The use of manual override is not recommended in SIL applications. If it is necessary, strictly follow instructions reported in the following paragraphs.

⚠ Before operating the manual override, ensure that the cylinder is not pressurised and that the actuator is in the fail position, then proceed as indicated in the following paragraphs.

For the hydraulic manual override installation and operation procedures refer to PUB016-004-00.

⚠ After each use, verify that the manual override has been disengaged.

12. Operation

12.4 Angular stroke setting

⚠️ Certain valves incorporate their own stops. For such valves, it is recommended that the actuator stop bolt positions coincide with the valve stop position.

Contact the valve manufacturer to set the valve mechanical stops.

⚠️ An incorrect setting of angular stroke could cause damages to the actuator, valve and/or to personnel.

⚠️ During the angular stroke setting procedure, an oil leakage from the stop bolt is expected.

12.4.1 Single/double-acting actuator, cylinder stop bolt setting

Perform the following operations as first setting.

Adjust the stop bolt located in the end flange of the cylinder as follows:

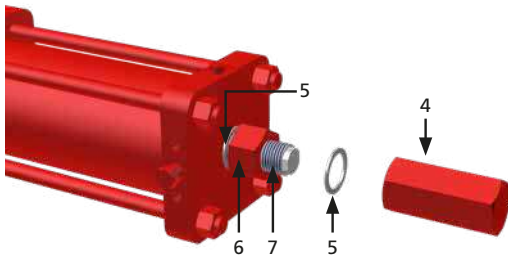

- Verify the absence of pressure
- Remove cap nut (4) and seal washer (5)
- Loosen stop nut (6)
- Slowly pressurise the cylinder to detach stop bolt (7) from piston

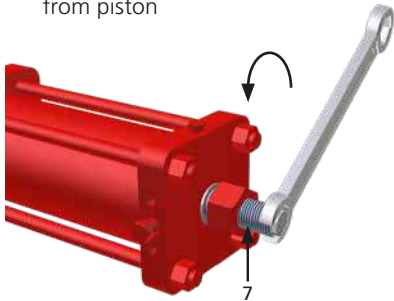

- With the help of a suitable size wrench, rotate the stop bolt (7) counter clockwise to increase the angular stroke
- Verify the newly obtained angular position with one stroke
- Repeat operations E to F, until the desired angle is obtained

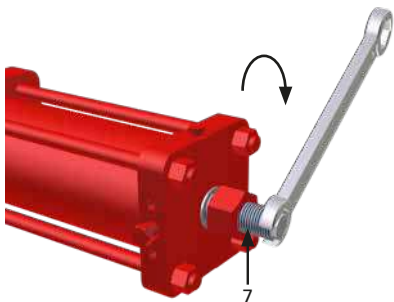

- With the help of a suitable size wrench, rotate the stop bolt (7) clockwise to decrease the angular stroke
- Verify the newly obtained angular position with one stroke
- Repeat operations H to I, until the desired angle is obtained
- Re-position the seal washer (5) between flange and the stop nut (7) and verify it is correctly positioned

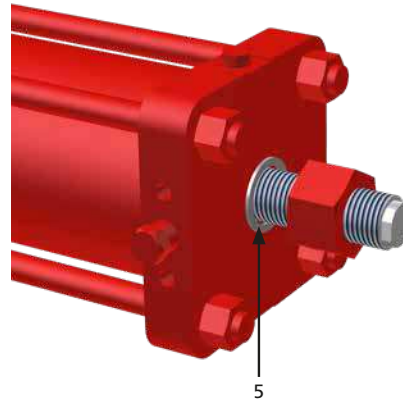

- Hold the stop bolt (7) with a wrench and carefully tighten the stop nut (6)

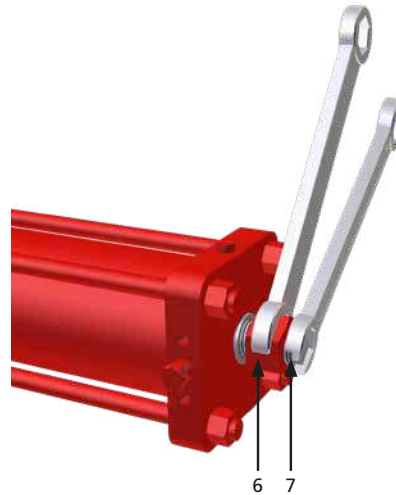

- Re-position the seal washer (5) and verify it is correctly positioned. Tighten cap nut (4)

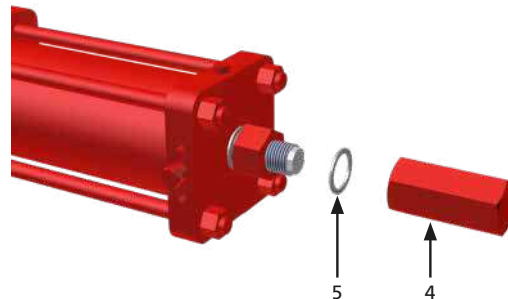

NOTE: for some cylinder sizes seal washers (5) are replaced by O-rings – the above procedure is applicable as well.

12. Operation

12.4.2 Single-acting actuator, spring cartridge stop bolt setting

Perform this setting after having set the stop bolt on cylinder.

Adjust stop bolt (3) screwed into the spring cartridge, as follows:

- Pressurise the cylinder until reaching the fully open/close position, and verify the actuator stroke stop
- Depressurise the cylinder to adjust the angular stroke setting
- Remove protection plug (1) with a wrench

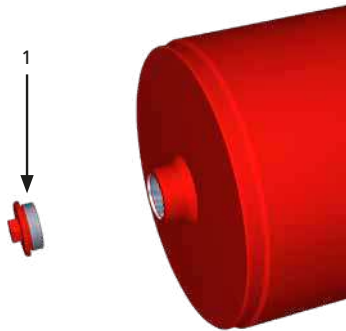

- To increase angular stroke, rotate stop bolt anti-clockwise with appropriate socket wrench



- To decrease angular stroke, rotate the stop bolt clockwise with appropriate socket wrench



- Verify the newly obtained angular position with one stroke
- Repeat this operation until the desired angle is obtained
- Re-position protection plug (1)

12.4.3 Double-acting actuator, centre body closure flange stop bolt setting

Perform the following operations after cylinder stop bolt setting.

Adjust the stop bolt located in the centre body closure flange as follows:

- Slowly apply pressure to port (X1)

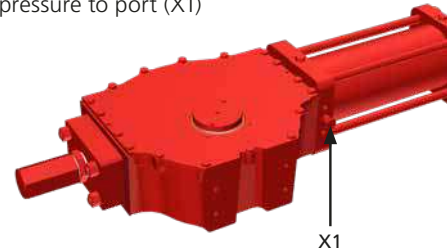

- Remove cap nut (1) with seal washer (2)

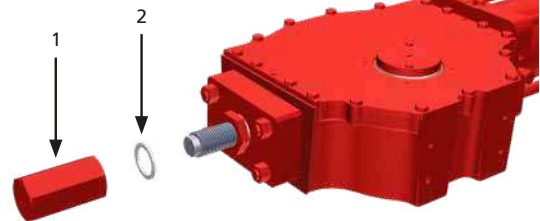

- Loosen stop nut (3)

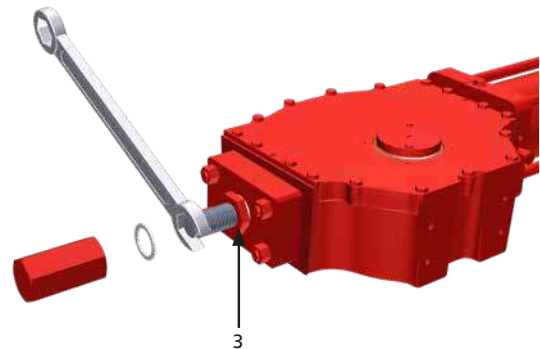

- To increase angular stroke, rotate stop bolt (5) anti-clockwise
- Verify the newly obtained angular position with one stroke
- Repeat operations D to E, until the desired angle is obtained

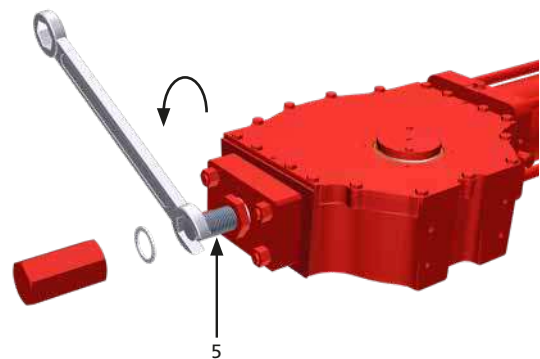

12. Operation

- G. To decrease angular stroke, rotate stop bolt (5) clockwise
H. Verify the newly obtained angular position with one stroke
Repeat operations G to H, until the desired angle is obtained

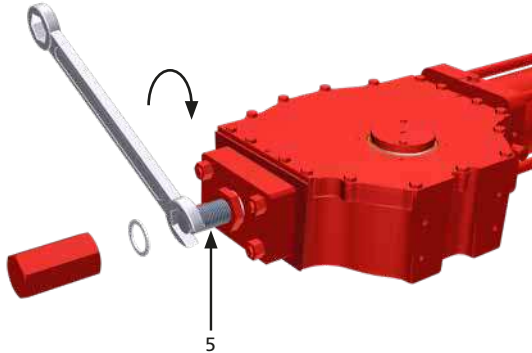

- I. Hold stop bolt (5) with a wrench and tighten stop nut (3). Ensure seal washer (2) is properly placed

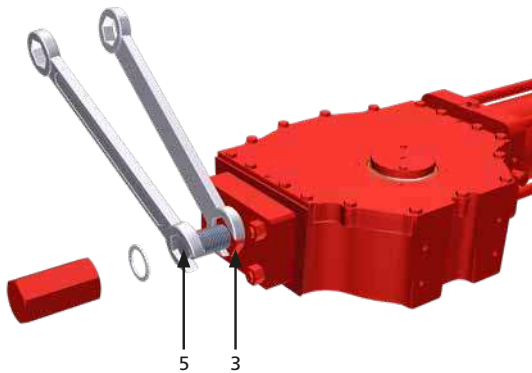

- J. Re-position seal washer (2) and verify it is correctly positioned. Tighten cap nut (1)

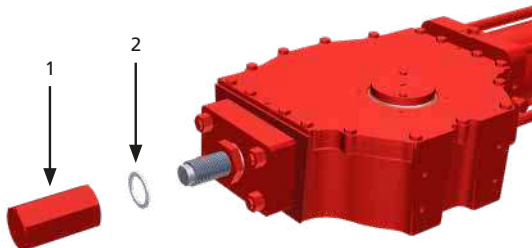

12.5 Hydraulic power supply

Verify allowed supply pressure range on actuator label.

⚠ Verify the medium composition. Contact Rotork to check the compatibility with the supply medium.

12.6 Hydraulic connections

Preliminary operations:

- Verify sizes of pipes and fittings per applicable plant specifications
- Clean the inside of the connection pipes by washing them with a suitable detergent and by blowing air into them
- The connecting pipes must be properly shaped and fixed to prevent stress or loosening of threaded connections

NOTE: For tapered-thread fluid connections, apply a thin layer of thread sealing product (Loxal 56-14 or equivalent) to ensure a good seal.

⚠ Connect the hydraulic power source in accordance to the applicable operating diagram, please refer to specific job for details.

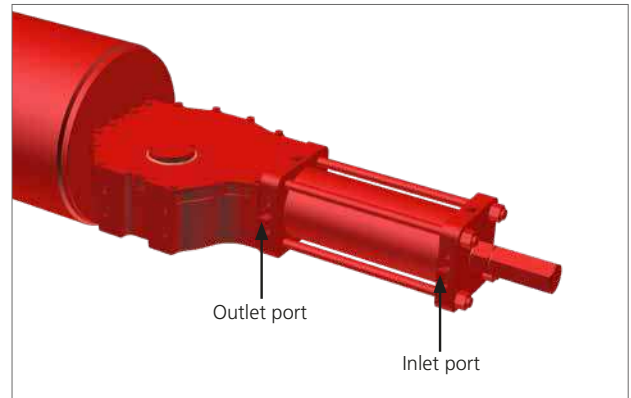

Fig 12.5 Inlet/outlet port for single-acting actuator

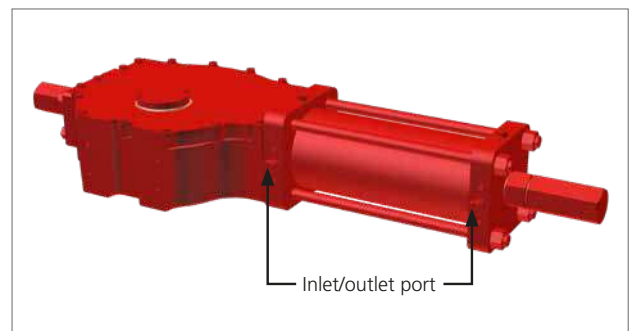

Fig 12.6 Inlet exhaust port for double-acting actuator

12. Operation

12.7 Electrical connections

⚠ Check electrical components' supply voltage, before start-up.

⚠ Access to live electrical conductors is forbidden in hazardous areas unless done under a special permit. Otherwise, all power must be isolated and the unit moved to a non-hazardous area for repair.

⚠ Prevent electrostatic charges in potentially explosive areas.

Electrical connection can be performed as follows:

- Remove the power supply
- Remove the plastic protection plugs from the cable entries
- Use only appropriately-certified reduction fittings, cable glands, fittings and explosionproof cables
- The cable glands must be tightened in the threaded inlets, to guarantee the waterproof and explosion protection
- Pay attention to the correct installation of the O-rings of the cable glands to prevent water and debris infiltration inside electric components
- The size of the electric supply cable must be per the electric power demand
- Insert the connection cables through cable glands and perform assembly per the cable gland manufacturer's instructions
- Connect the cable wires to the terminal blocks in accordance with the applicable wiring diagram
- Electric connections must be made by using rigid conduits and trailing cables to prevent mechanical stresses in the cable entries
- On the unused entries of the junction box, replace the plastic plugs with approved metal plugs, to guarantee sealing and comply with explosion safety protection codes
- Assemble the covers of the electric components, paying attention to seals
- Once connections have been completed, check electrical components' functionality

⚠ Actuator and electrical components must be protected from electrical sparks, lightning, magnetic or electro-magnetic fields, at user's care.

⚠ Installation must be performed according to IEC 60079-14 and the end user must follow special conditions for safe use detailed in document PUB010-046.

12.8 Start up

During the start-up of the actuator, it is necessary to check if:

- The medium supply pressure is as prescribed
- The feed voltage values of electrical components (solenoid valves coils, limit switches, pressure switches etc., if applicable) are as prescribed
- Actuator controls such as remote control, local control, emergency control etc. (if applicable) work properly
- Input remote signals are correct
- The setting of control unit components is per the plant requirements
- Hydraulic connections show no leakage. If necessary, tighten fittings
- The painted parts have not been damaged during transport, assembling or storage operations. Otherwise remove presence of rust and repair the damaged parts following the applicable painting specifications
- Actuator and all its parties work as expected
- Operating time is in accordance with requirements

⚠ The end user must guarantee equal voltage potential between the valve and the actuator and provide appropriate grounding. The final user shall indicate and maintain the grounding connections on the actuator.

13. Dismantling and disposal

Prior to dismantling the actuator, check if any of its parts are still under pressure.

For single-acting actuator

⚠ The spring cartridge module contains potential energy due to compressed elastic elements.

After removing the spring cartridge from the centre body, the spring cartridge must be returned to the manufacturer's plant, upon agreement with Rotork.

♻ Grease and oil must be disposed of safely in accordance with the local environmental laws and regulations.

- Dismount the actuator, separate and divide the various parts and components per the type of material
- Dispose of the pieces of steel, cast iron and aluminium alloys as metal scraps
- Dispose of the rubber, PVC, resins etc. separately, in accordance with the existing national and regional regulations
- Electric components are to be separately disposed of on specialized disposal sites

Actuators manufactured after 1993 do not contain asbestos or its by-products.

14. Rotork sales and service

If your Rotork actuator has been correctly installed and sealed, it will give years of trouble-free service. Should you require technical assistance or spares, Rotork guarantees one of the highest levels of service in the flow control industry. Contact your local Rotork representative or the factory directly at the address on the nameplate, quoting the actuator type and serial number.

Some actuators have a special spare parts list. Refer to the project-specific documentation for further details.

15. Troubleshooting

ID	FAILURE	POSSIBLE CAUSES	CORRECTIVE MEASURES
1	Incorrect valve position	<ul style="list-style-type: none"> Fault of pipeline valve 	<ul style="list-style-type: none"> Consult the valve manufacturer's documentation
2	Incorrect indication of valve position	<ul style="list-style-type: none"> Incorrect signal from limit switches 	<ul style="list-style-type: none"> Check limit switches' position (according to instructions reported in the job specific documentation)
3	Incorrect movement	<ul style="list-style-type: none"> Irregular supply of operating medium 	<ul style="list-style-type: none"> Verify the supply pressure and adjust as necessary
		<ul style="list-style-type: none"> Worn parts 	<ul style="list-style-type: none"> Contact Rotork
		<ul style="list-style-type: none"> Fault in control panel equipment (if present) 	<ul style="list-style-type: none"> Contact Rotork customer service
		<ul style="list-style-type: none"> Fault of pipeline valve 	<ul style="list-style-type: none"> Consult the valve manufacturer's documentation
4	Valve stroke not fully completed	<ul style="list-style-type: none"> Insufficient flow of operating medium 	<ul style="list-style-type: none"> Increase flow of operating medium
		<ul style="list-style-type: none"> Incorrect assembly between actuator and valve 	<ul style="list-style-type: none"> Perform assembling according to INSTALLATION ON VALVE (Section 10)
		<ul style="list-style-type: none"> Valve blocked 	<ul style="list-style-type: none"> Consult the valve manufacturer's documentation
		<ul style="list-style-type: none"> Stop bolts wrong setting 	<ul style="list-style-type: none"> Adjust stop bolt setting following instructions in ANGULAR STROKE SETTING (Section 12.4)
5	Leakages	<ul style="list-style-type: none"> Stop bolts wrong setting 	<ul style="list-style-type: none"> Adjust stop bolt setting following instructions in ANGULAR STROKE SETTING (Section 12.4)
		<ul style="list-style-type: none"> Worn seals 	<ul style="list-style-type: none"> Replace seals according to PM-GH-006 (Section 16)
6	Actuator moves too fast	<ul style="list-style-type: none"> No pressure on pipeline 	<ul style="list-style-type: none"> Restore pipeline pressure
		<ul style="list-style-type: none"> Supply pressure greater than allowed range values 	<ul style="list-style-type: none"> Verify the supply pressure and adjust as necessary
7	Actuator moves too slow	<ul style="list-style-type: none"> Fault on pipeline valve (valve hardened) 	<ul style="list-style-type: none"> Consult the valve manufacturer's documentation
		<ul style="list-style-type: none"> Supply pressure lower than allowed range values 	<ul style="list-style-type: none"> Verify the supply pressure and adjust as necessary
		<ul style="list-style-type: none"> Possible internal undue friction 	<ul style="list-style-type: none"> Contact Rotork customer service
8	Loss of power	<ul style="list-style-type: none"> Inadequate supply pressure 	<ul style="list-style-type: none"> Ensure that the supply pressure is above the minimum operating pressure of the actuator and that the output torque produced at supply pressure exceeds the required valve torque
		<ul style="list-style-type: none"> Leakage from cylinder 	<ul style="list-style-type: none"> Replace seals according to PM-GH-006 (Section 16)

For other problems, please contact Rotork customer service.

16. Periodic maintenance

Rotork recommends performing the following checks to help comply with the rules and regulations of the country of final installation:

⚠ Remove pressure before proceeding with maintenance operations, discharge any accumulators or tanks (if present), except where otherwise indicated.

Periodic maintenance schedule



MAINTENANCE ACTIVITY	PERIODICITY		REFERENCE
	Months	Years	
Visual check of external components and control groups	6*	*	
Verify welding. In case of anomalies contact Rotork	6*	*	
Breather cleaning	6*	*	
Check hydraulic connections for leaks. Tighten pipe fittings as required	-	1*	
Cleaning	-	1*	PM-GH-001
Visual check of painting. Verify absence of damages. Repair if necessary per painting specification	-	1*	
Functional test	-	1*	PM-GH-002
Functional test by manual override	-	1*	PM-GH-003
Check electrical components (if present) and grounding connections	-	1*	PM-GH-004
Check threaded connections (bolts, studs and nuts) with valve. If necessary tighten to the recommended torque, in accordance with the size and the characteristics of the fastener material installed by the customer		1*	
Single-acting actuator hand pump oil replacement (if present)	-	5*	PM-GH-005a
Double-acting actuator hand pump oil replacement (if present)	-	5*	PM-GH-005b
Hydraulic cylinder and centre body seals replacement (single- and double-acting actuator)	-	5*	PM-GH-006

(* The time between maintenance tasks will vary depending on the medium and service conditions. Refer to End User Plant Preventive Maintenance Program for specific task periodicity.

For functional safety applications refer to safety manual.

Specific maintenance could be necessary for specific application. Refer to job documentation for eventual additional maintenance tasks.



16. Periodic maintenance

PM-GH-001		Page: 1/1
Component: Single-acting actuator Double-acting actuator	Task: Cleaning	
Equipment, tools, materials: Air compressor Project documentation (design and operating pressure values)	Warnings: 	
Preliminary operations:		
Description:  Remove electric and hydraulic supply before proceeding. 1. Remove dust from actuator external surface using a damp cloth or compressed air  Do not polish/rub non-metal surfaces with a dry cloth. The tools and cleaning procedures must not produce sparks or create adverse conditions in the environment during maintenance operations, to prevent potential explosion hazards. Prevent electrostatic charges in potentially explosive areas.		



16. Periodic maintenance

PM-GH-002		Page: 1/1
Component: Single-acting actuator Double-acting actuator	Task: Functional test	
Equipment, tools, materials: Chronometer Project documentation (required stroke times)	Warnings: 	
Preliminary operations:		
Description: NOTE: Actuator must be connected to the hydraulic supply to perform the following test. <ol style="list-style-type: none">1. Operate the actuator2. Perform the stroke several times by local and remote (if applicable) control <p>⚠ Actuator could exhaust medium supply in the atmosphere during normal operation. Wear PPE including breathing device in function of type of medium supply used.</p> <ol style="list-style-type: none">3. Verify actuator is correctly working4. Note the stroke time(s)5. Verify stroke time(s) are as required <p>In case of stroke times out of required range refer to Troubleshooting ID 4, 5 (Section 15) to restore.</p>		



16. Periodic maintenance

PM-GH-003		Page: 1/1
Component: Manual override	Task: Manual override functional test	
Equipment, tools, materials: Project documentation	Warnings: 	
Preliminary operations:		
Description:		
Opening operation		
<ol style="list-style-type: none">1. Verify the absence of pressure2. Verify the actuator is in its fail position, spring relaxed (for single-acting actuator)3. Move the mechanical manual override according to instructions reported in MANUAL OVERRIDE (Section 12.3) to stroke the actuator4. Verify the actuator reaches the desired position		
 Before re-starting the actuator with air supply, disengage the manual override to set the actuator in its original position. After each use, verify that the manual override has been disengaged before returning to remote operation.		



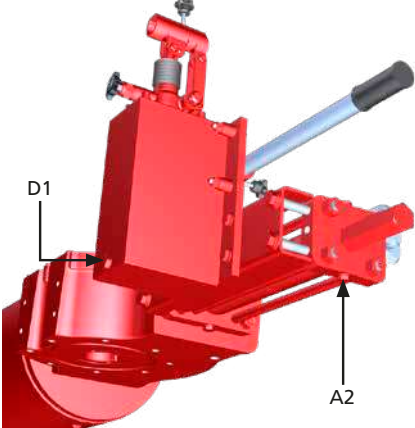
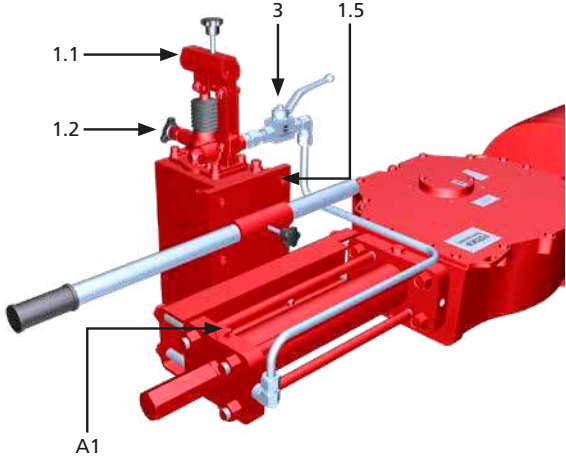

16. Periodic maintenance

		PM-GH-004	Page: 1/1
Component: Electrical components (if present)		Task: Check electrical components (if present) and grounding connections	
Equipment, tools, materials: Project documentation		Warnings: 	
Preliminary operations:			
Description:  Switch off the electric power supply before working on electrical devices. Read and follow the safety precautions reported in the manufacturer's maintenance manual. Risk of temporary modification of the component protection. Use only antistatic clothes. <ol style="list-style-type: none">1. Remove the cover from electric components2. Check the electric device components3. Verify tightness of the terminal blocks4. Verify absence of humidity and oxidation5. Check the cable gland seals6. Verify the grounding connection and restore if necessary			

16. Periodic maintenance

PM-GH-005a		Page: 1/1
Component: Hydraulic manual override for single-acting actuators	Task: Hydraulic oil replacement	
Equipment, tools, materials: Project documentation Wrench	Warnings: 	
Preliminary operations:		
Description: Tasks must be executed with the tank in vertical position and with the actuator in fail position. Verify the absence of hydraulic pressure. Correct oil level is approximately 25 mm (1") below the fill/breather port.		
Drain procedure		
<ol style="list-style-type: none"> 1. Remove breather/plug (1.5) 2. Place containers under drain port (D1) and (A2) to collect the fluid 3. Remove plugs (D1), (A1) and (A2) 4. Discharge oil 5. Tighten plug (D1) and (A2) back in its seat with a wrench 6. Hand tighten plug (A1) and unfasten 1 turn <p> Used hydraulic fluid must be disposed of safely.</p>		
Filling procedure		
<ol style="list-style-type: none"> 7. Fill with oil from the fill/breather port (1.5) up to 25 mm (1") below the port 8. Close stop valve (1.2) and verify that stop valve (3) is open 9. Install the pump lever and operate pump (1.1) until oil is bled from port A1 10. Tighten plug (A1) with a wrench 11. Continue operating the pump to fully compress the spring 12. Ensure the oil level in the tank does not drop below the intake tube 13. Keep the cylinder pressurised from 3 to 5 minutes, to settle the oil level 14. Slowly open stop valve (1.2) to allow the actuator the return to the fail position 15. Repeat the pump operation procedure from 2 to 3 times 16. Check the oil level. If necessary, fill in from the fill/breather port (1.5) up to 25 mm (1") below the port <p>Important: Do not exceed this fluid level.</p> <ol style="list-style-type: none"> 17. Reinstall the tank breather (1.5) and return the lever to the storage holder 		

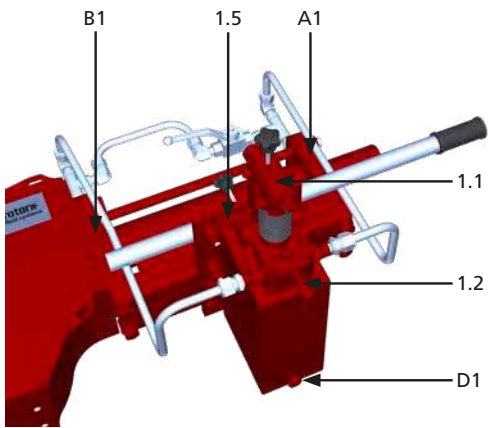
16. Periodic maintenance

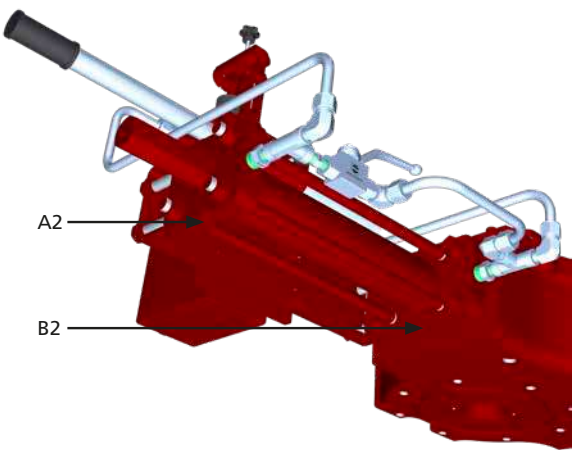
PM-GH-005b		Page: 1/1
Component: Hydraulic manual override for double-acting actuator	Task: Hydraulic oil replacement	
Equipment, tools, materials: Project documentation Wrench	Warnings: 	
Preliminary operations:		
Description: Tasks must be executed with the tank in a vertical position. Verify the absence of hydraulic pressure. Correct oil level is approximately 25 mm (1 ") below the fill/breather port.		
Drain procedure		
<ol style="list-style-type: none"> 18. Remove breather/plug (1.5) 19. Place containers under drain port (D1), (A2) and (B2) to collect the fluid 20. Loosen plugs (D1), (A1), (B1), (A2) and (B2) 21. Discharge oil 22. Tighten plug (D1), (A2) and (B2) back in its seat with a wrench 23. Hand tighten plug (A1) and (B1) and unfasten both 1 turn <p> Used hydraulic fluid must be disposed of safely.</p>		
Filling procedure		
<ol style="list-style-type: none"> 24. Fill with oil from the fill/breather port (1.5) up to 25 mm (1 ") below the port 25. Move the open/close selector (1.2) to the outboard side of the hydraulic cylinder 26. Install the pump lever and operate pump (1.1) until oil is bled from port A1 27. Tighten plug (A1) with a wrench 28. Continue operating the pump to the end of the actuator stroke 29. Ensure the oil level in the tank does not drop below the intake tube 30. Move the open/close selector (1.2) to the inboard side of the hydraulic cylinder 31. Operate pump (1.1) until oil is bled from port B1 32. Tighten plug (B1) with a wrench 33. Continue operating the pump to the end of the actuator stroke 34. Ensure the oil level in the tank does not drop below the intake tube 35. Stroke the actuator with the pump in both direction from 2 to 3 times 36. Check the oil level. If necessary, fill in from the fill/breather port (1.5) up to 25 mm (1 ") below the port <p>Important: Do not exceed this fluid level</p> <ol style="list-style-type: none"> 37. Reinstall the tank breather (1.5) and return the lever to the storage holder. <p> In case 2 off 3/2 manual operated valves are installed in the above circuit, switch them both to the local/manual position before the above procedure. For further information refer to the job documentation.</p>		

16. Periodic maintenance

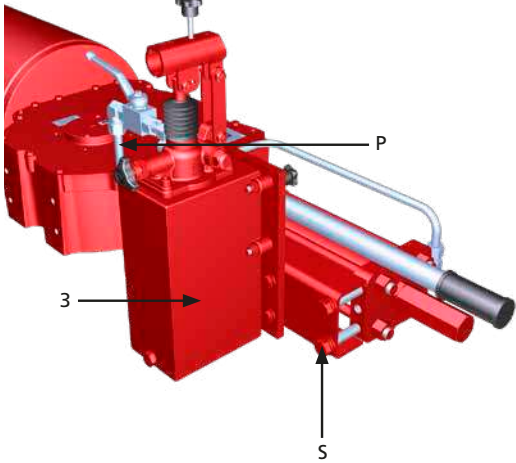
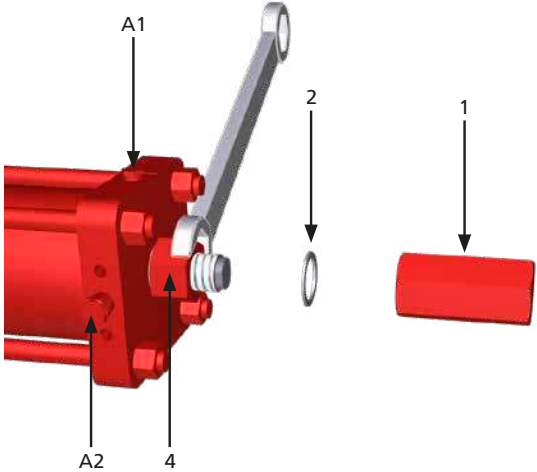
PM-GH-006		Page: 1/16
Component: Single-acting actuator / double-acting actuator	Task: Hydraulic cylinder and centre body seals replacement	
Equipment, tools, materials: Spare seals Wrench Lifting tools Project documentation	Warnings: 	
Preliminary operations: Removal from valve		
Description:		
Note: the following instructions apply both to single-acting and double-acting actuators unless otherwise specified.		
<p>⚠ Cut-off the power supply and electric power supply (if present) before performing any operation. Adequate lifting devices and suitable for the weight must be applied by skilled personnel.</p>		
Preliminary actions		
<ol style="list-style-type: none"> 1. Verify actuator is in the fail position (single-acting) and not pressurised 2. Remove actuator from valve (Section 11) 3. Position the actuator on a workbench (if possible) or in a stable position and in a clean and closed area 4. Remove any control equipment (if present). Refer to the project specific documentation 5. Remove pipes 		
<ol style="list-style-type: none"> 6. Remove hydraulic pipe (P) – if present 7. Unscrew bolts (S) and remove hydraulic pump assembly (3) – if present 		
<ol style="list-style-type: none"> 8. Remove plugs A1 and A2 to drain oil 9. Collect the oil and dispose of properly 10. Hold stop nut (4) with a wrench, unscrew and remove cap nut (1) with seal washer (2) 		

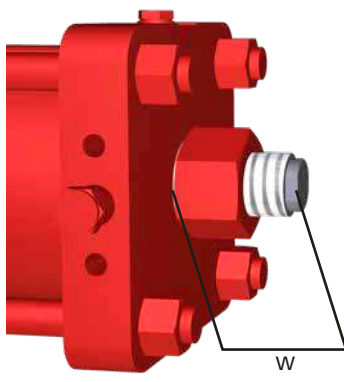
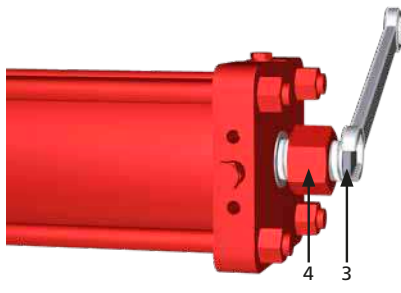
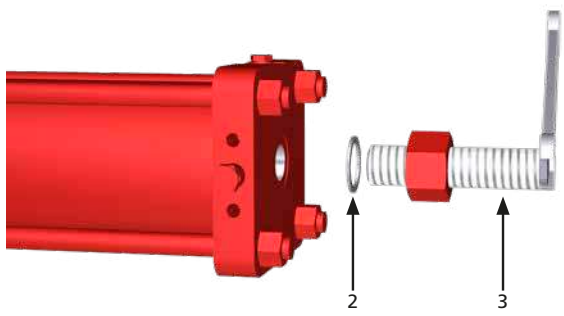

16. Periodic maintenance

		PM-GH-006	Page: 2/16
Component: Single-acting actuator / double-acting actuator		Task: Hydraulic cylinder for manual override seals replacement	
Equipment, tools, materials: Spare seals Wrench Lifting tools Project documentation		Warnings: 	
Preliminary operations: Removal from valve			
11. Measure length (W)			
12. Hold stop bolt (3) with a wrench and loosen the stop nut (4)			
13. Fully unscrew stop bolt (3) and remove seal washer (2) 14. Sustain the hydraulic cylinder adequately			

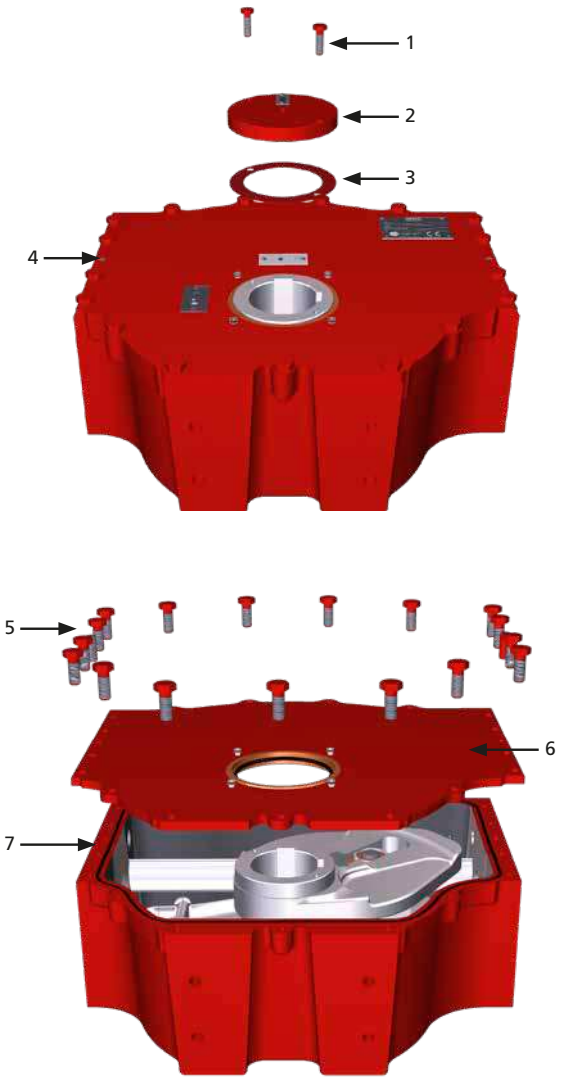
16. Periodic maintenance

PM-GH-006		Page: 3/16
Component: Single-acting actuator / double-acting actuator	Task: Hydraulic cylinder for manual override seals replacement	
Equipment, tools, materials: Spare seals Wrench Lifting tools Project documentation	Warnings: 	
Preliminary operations: Removal from valve		
<ol style="list-style-type: none">15. Unscrew screws (1) and remove position indicator (2) with gasket (3)16. Unscrew bolts (5) and parallel pin (4)17. Remove cover (6). To facilitate the operation, screw two bolts into proper threaded holes on the cover18. Remove and replace O-ring (7)		

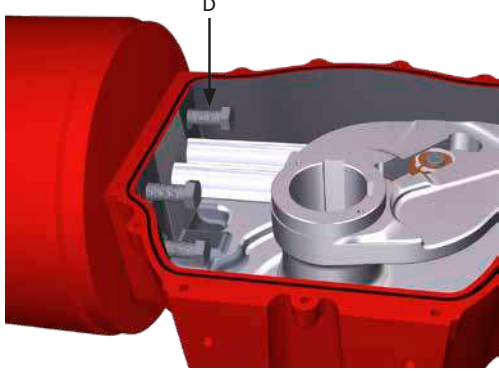

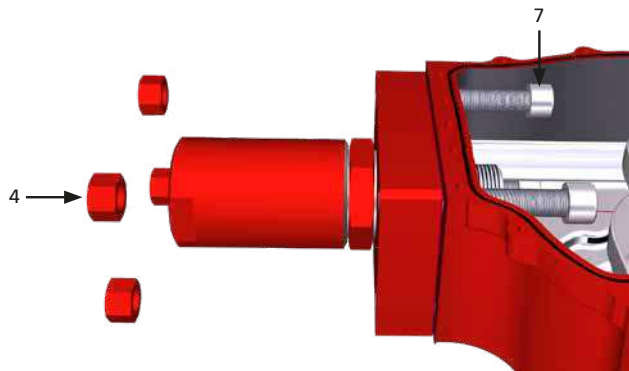
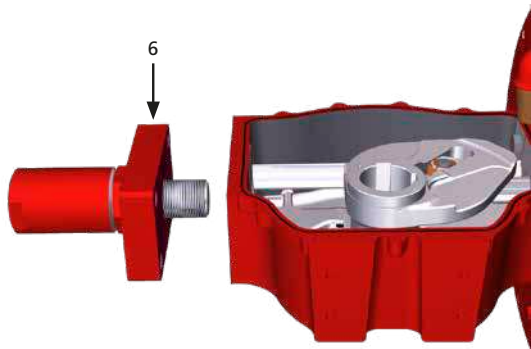
16. Periodic maintenance

		PM-GH-006	Page: 4/16
Component: Single-acting actuator / double-acting actuator		Task: Hydraulic cylinder for manual override seals replacement	
Equipment, tools, materials: Spare seals Wrench Lifting tools Project documentation		Warnings: 	
Preliminary operations: Removal from valve			
Instructions valid only for SINGLE-ACTING ACTUATOR 19. Sustain the spring cartridge adequately 20. Unscrew bolts (D) carefully ⚠ The spring cartridge module can exert a thrust against the centre body. Unscrew bolts (D) gradually, all at the same time to release the spring energy.			
21. Remove the spring container and centring ring (D1) 22. Remove and replace eventual gasket or O-ring (see specific part list) between spring container and centre body			
Instructions valid only for DOUBLE-ACTING ACTUATOR 23. Unscrew nuts (4) from bolts (7)			
24. Remove flange (6) 25. Remove and replace the eventual gasket or O-ring (see specific part list) between the flange and centre body			

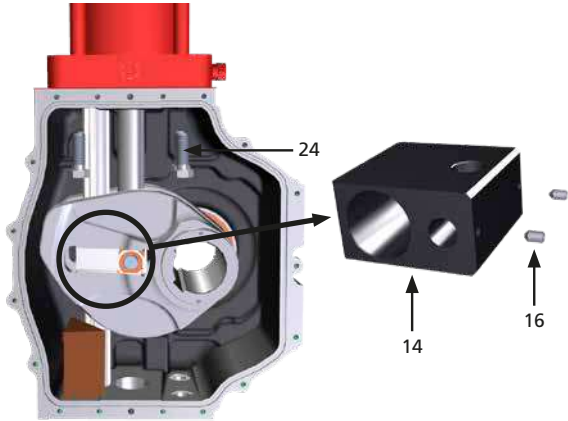
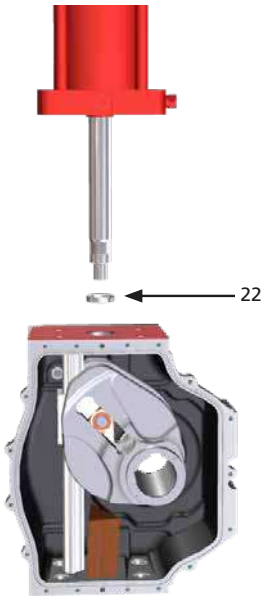
16. Periodic maintenance

PM-GH-006		Page: 5/16
Component: Single-acting actuator / double-acting actuator	Task: Hydraulic cylinder and centre body seals replacement	
Equipment, tools, materials: Spare seals Wrench Lifting tools Project documentation	Warnings: 	
Preliminary operations: Removal from valve		
<p>Instructions valid for SINGLE-ACTING ACTUATOR and DOUBLE EFFECT ACTUATOR</p> <ol style="list-style-type: none"> 26. Position the actuator vertically on a workbench 27. Secure the actuator to the workbench with suitable clamps 28. Hook the cylinder with a suitable textile sling 29. Unscrew set screw (16) from guide block (14) 30. Use a suitable support to sustain the yoke (preventing rotation) to keep the guide block (14) horizontal <p>Important: Remove eventual dents caused by the set screw on the piston rod</p> <ol style="list-style-type: none"> 31. Unscrew and remove bolts (24) 		
<ol style="list-style-type: none"> 32. Rotate the cylinder counter-clockwise to unscrew the piston rod and remove cylinder tube 33. Remove centring ring (22) 		

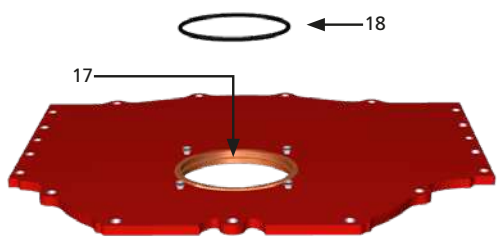
16. Periodic maintenance

PM-GH-006		Page: 6/16
Component: Single-acting actuator / double-acting actuator	Task: Hydraulic cylinder and centre body seals replacement	
Equipment, tools, materials: Spare seals Wrench Lifting tools Project documentation	Warnings: 	
Preliminary operations: Removal from valve		
34. Remove O-ring (18) from cover bushing (17), clean the bushing groove, replace new O-ring (18) and lubricate as appropriate		
35. With the help of a rubber hammer remove the axial bar (10)		

16. Periodic maintenance

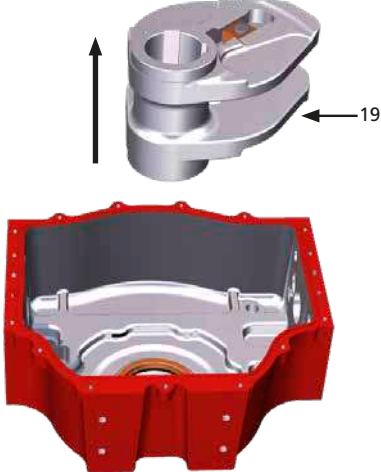
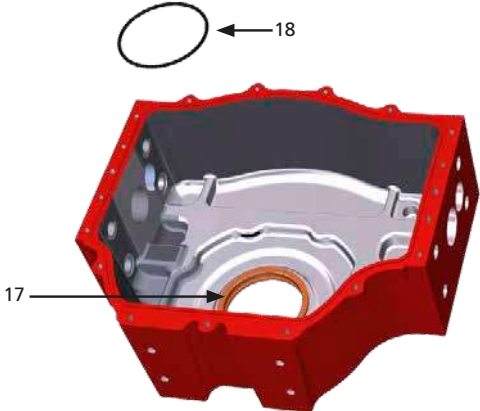
PM-GH-006		Page: 7/16
Component: Single-acting actuator / double-acting actuator	Task: Hydraulic cylinder and centre body seals replacement	
Equipment, tools, materials: Spare seals Wrench Lifting tools Project documentation	Warnings: 	
Preliminary operations: Removal from valve		
36. Remove yoke group (19) from enclosure		
37. Remove O-ring (18) from enclosure bushing (17), clean the bushing groove, replace new O-ring (18) and lubricate as appropriate		

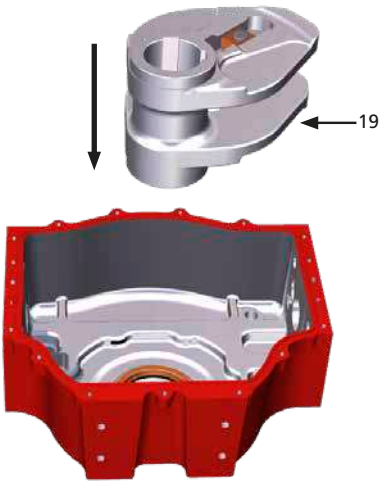
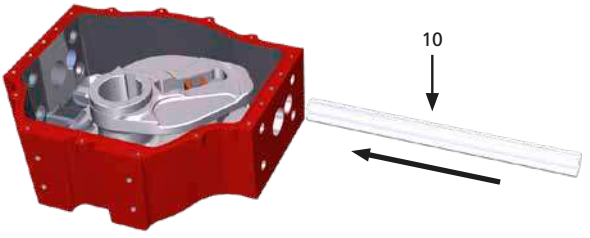

16. Periodic maintenance

PM-GH-006		Page: 8/16
Component: Single-acting actuator / double-acting actuator	Task: Hydraulic cylinder and centre body seals replacement	
Equipment, tools, materials: Spare seals Wrench Lifting tools Project documentation	Warnings: 	
Preliminary operations: Removal from valve		
38. Replace yoke group (19) in the enclosure		
39. With the help of a rubber hammer replace the axial bar (10)		

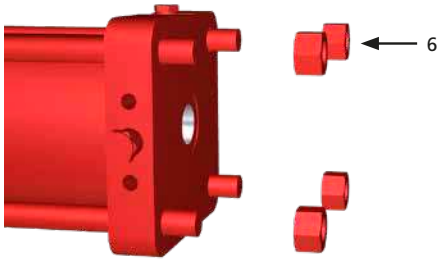
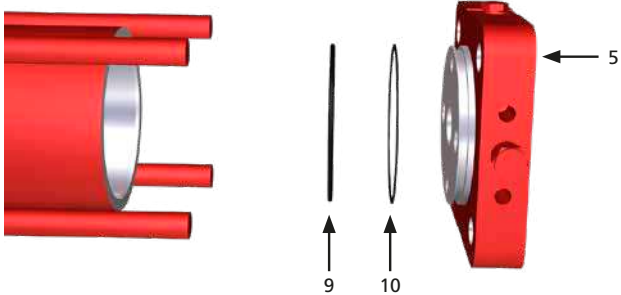
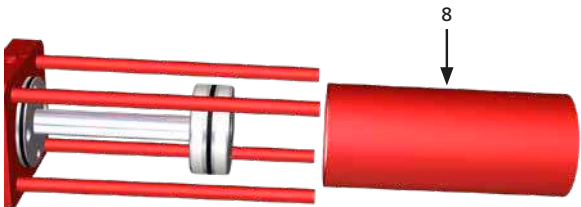
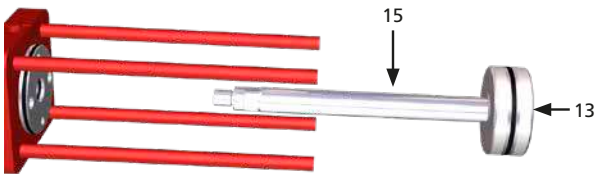

16. Periodic maintenance

PM-GH-006		Page: 9/16
Component: Single-acting actuator / double-acting actuator	Task: Hydraulic cylinder and centre body seals replacement	
Equipment, tools, materials: Spare seals Wrench Lifting tools Project documentation	Warnings: 	
Preliminary operations: Removal from valve		
40. Unscrew bolts (6)		
41. Remove end flange (5) with O-ring (9) and back up ring (10)		
42. Remove cylinder tube (8)		
43. Remove piston assembly (13) and piston rod (15)		

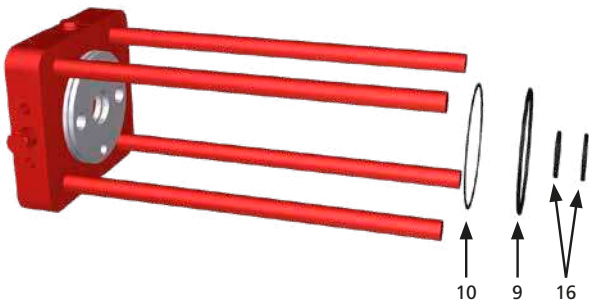

16. Periodic maintenance

		PM-GH-006	Page: 10/16
Component: Single-acting actuator / double-acting actuator		Task: Hydraulic cylinder and centre body seals replacement	
Equipment, tools, materials: Spare seals Wrench Lifting tools Project documentation		Warnings: 	
Preliminary operations: Removal from valve			
44. Remove sliding ring (11) and O-ring (12)			
45. Remove O-ring (9), back-up ring (10) and piston rod seals (16) from the head flange			
46. Carefully clean all seal grooves 47. Clean all removed parts 48. Replace all the mentioned seals and lubricate grooves using recommended grease/oil 49. Lubricate all sliding parts			

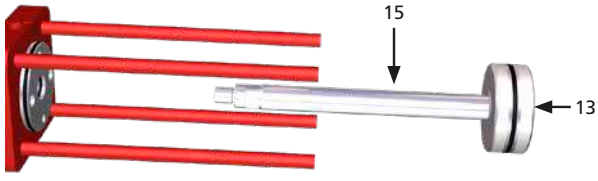
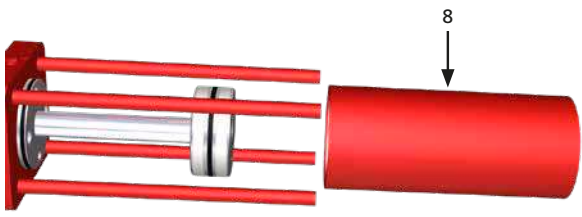
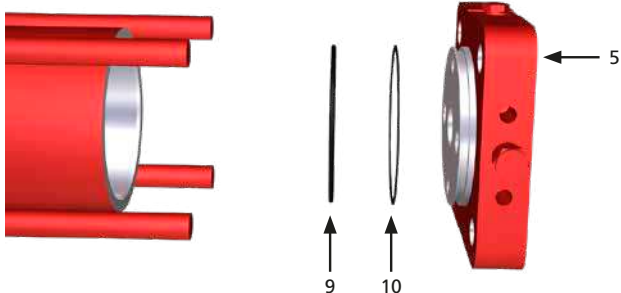
16. Periodic maintenance

PM-GH-006		Page: 11/16
Component: Single-acting actuator / double-acting actuator	Task: Hydraulic cylinder and centre body seals replacement	
Equipment, tools, materials: Spare seals Wrench Lifting tools Project documentation	Warnings: 	
Preliminary operations: Removal from valve		
50. Assemble sliding ring (11) and O-ring (12) on piston (13)		
51. Install O-ring (9), back-up ring (10) and piston rod seals (16) on head flange (18)		
52. Install piston assembly (piston (23) and piston rod (15)) on head flange (18)		
53. Install cylinder tube (8)		
54. Install O-ring (9) and back-up ring (10) on end flange (5)		

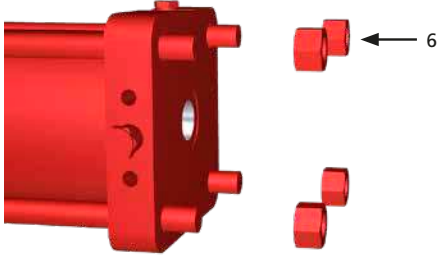
16. Periodic maintenance

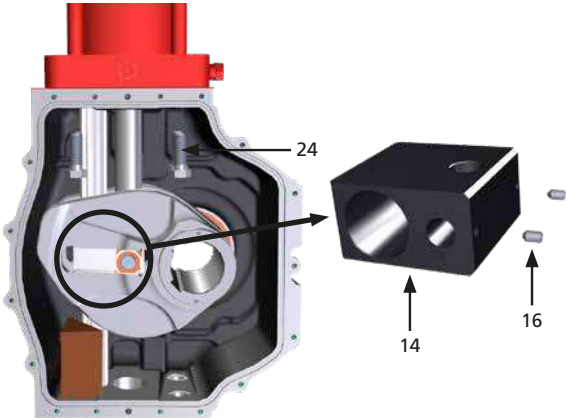
		PM-GH-006	Page: 12/16
Component: Single-acting actuator / double-acting actuator		Task: Hydraulic cylinder and centre body seals replacement	
Equipment, tools, materials: Spare seals Wrench Lifting tools Project documentation		Warnings: 	
Preliminary operations: Removal from valve			
55. Assemble the end flange and tighten nuts (6) to the recommended tightening torque			
56. Install centring ring (22) 57. Position the cylinder assembly on the centre body			
58. Rotate the cylinder clockwise to screw piston rod (23) into guide block (14) 59. Lock with set screw (16) within the guide block (14) 60. Apply a film of Loctite 243 on bolts (24) and tighten following a cross-bolt tightening sequence to the recommended torque			

16. Periodic maintenance

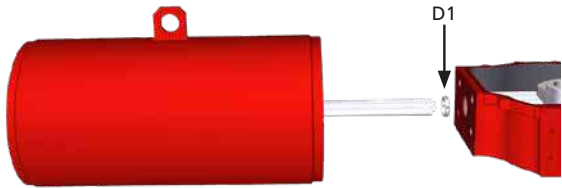
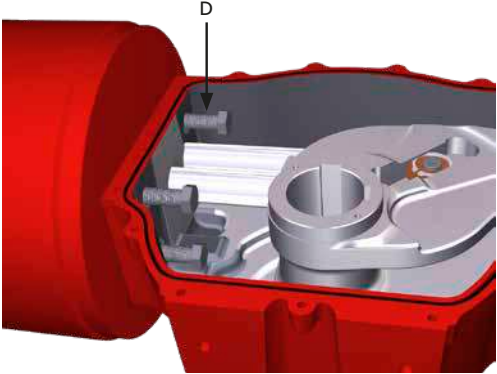
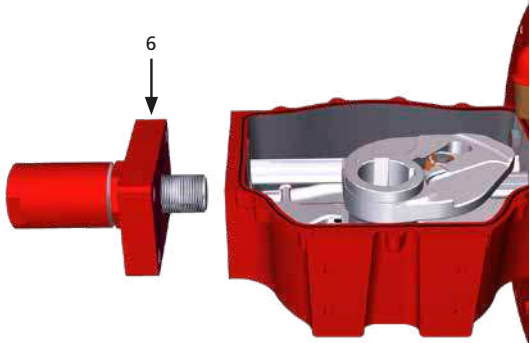
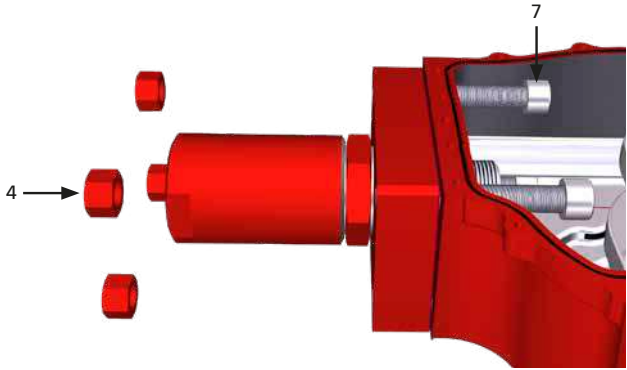
PM-GH-006		Page: 13/16
Component: Single-acting actuator / double-acting actuator	Task: Hydraulic cylinder and centre body seals replacement	
Equipment, tools, materials: Spare seals Wrench Lifting tools Project documentation	Warnings: 	
Preliminary operations: Removal from valve		
Instructions valid only for SINGLE-ACTING ACTUATOR 61. Restore the eventual gasket or O-ring (see specific part list) between the spring container and centre body 62. Position centring ring (D1) and slide spring container within the centre body		
Instructions valid only for SINGLE-ACTING ACTUATOR 63. Apply a film of Loctite 243 on bolts (D) and tighten to the recommended torque, following a cross-bolt tightening sequence Note: Lubricate the sliding components of the scotch yoke mechanism (Section 18.1).		
Instructions valid only for DOUBLE-ACTING ACTUATOR 64. Restore the eventual gasket or O-ring (see specific part list) between the spring container and centre body 65. Position flange (6)		
Instructions valid only for DOUBLE-ACTING ACTUATOR 66. Apply a film of Loctite 243 on bolts (7) and tighten bolts and nuts (4) to the recommended torque, following a cross-bolt tightening sequence Note: Lubricate the sliding components of the scotch yoke mechanism (Section 18.1).		

16. Periodic maintenance

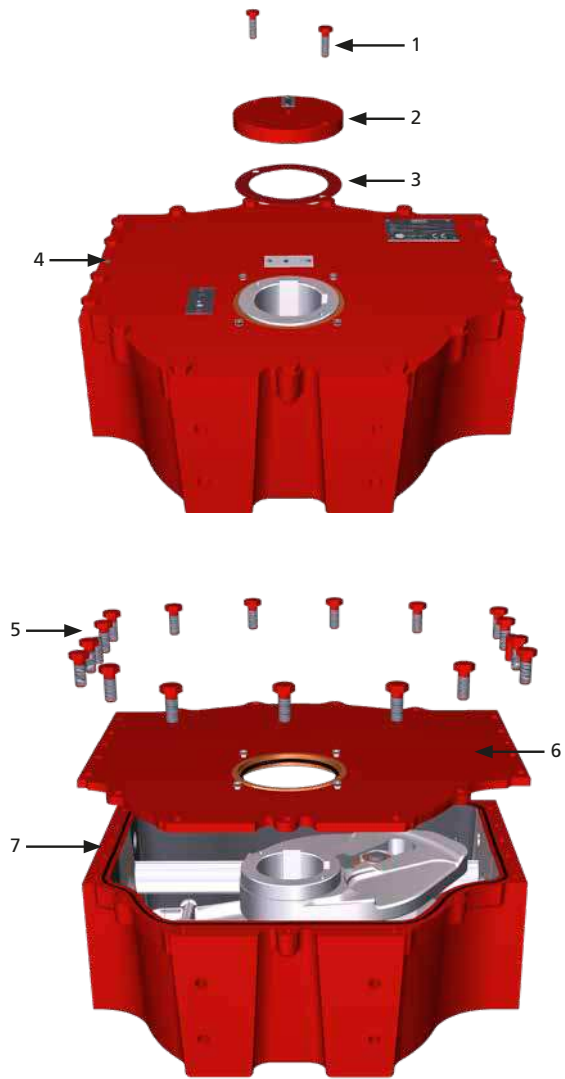
		PM-GH-006	Page: 14/16
Component: Single-acting actuator / double-acting actuator		Task: Hydraulic cylinder and centre body seals replacement	
Equipment, tools, materials: Spare seals Wrench Lifting tools Project documentation		Warnings: 	
Preliminary operations: Removal from valve			
67. Replace O-ring (7) 68. Position the cover (6) on the centre body			
<p>⚠ Clean and degrease the coupling bolts (5) and parallel pins (4). Apply a thin layer of thread sealing product (Loxal 53.14 or equivalent Loctite 566) on bolts (5) and pins (4), to preserve actuator ingress protection level.</p> 69. Fix parallel pins (4) and tighten bolts (5) 70. Restore position indicator (2) with relative gasket (3) and tighten bolts (1)			

16. Periodic maintenance

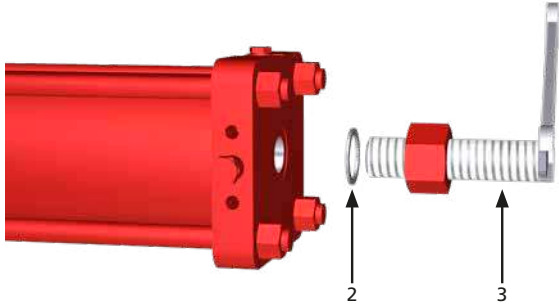
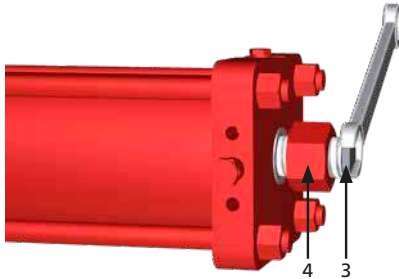
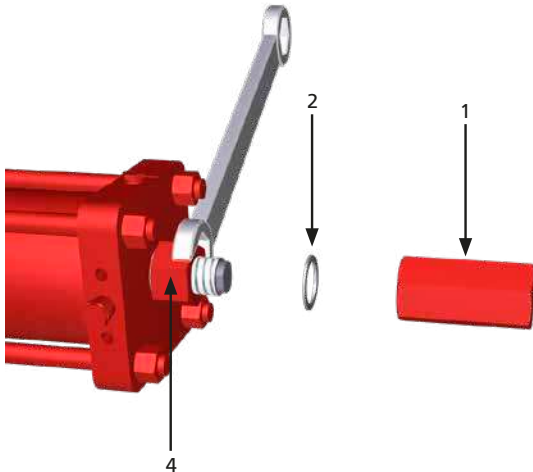
PM-GH-006		Page: 15/16
Component: Single-acting actuator / double-acting actuator	Task: Hydraulic cylinder and centre body seals replacement	
Equipment, tools, materials: Spare seals Wrench Lifting tools Project documentation	Warnings: 	
Preliminary operations: Removal from valve		
71. Assemble seal washer (2) in its correct position and stop bolt (3) to length W		
72. Hold the stop bolt with a wrench and tighten stop nut (4)		
73. Hold stop nut (4), install seal washer (2) in its correct position and tighten cap nut (1)		

16. Periodic maintenance

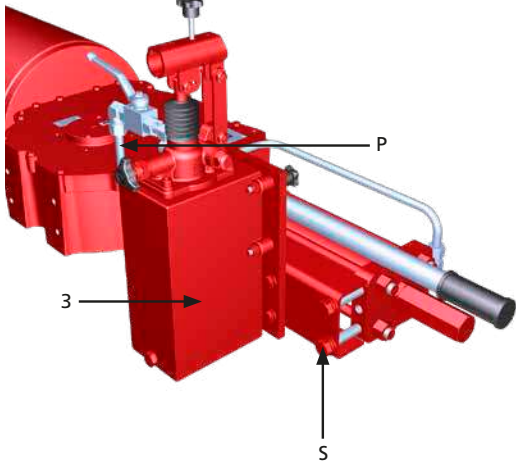
		PM-GH-006	Page: 16/16
Component: Single-acting actuator / double-acting actuator		Task: Hydraulic cylinder and centre body seals replacement	
Equipment, tools, materials: Spare seals Wrench Lifting tools Project documentation		Warnings: 	
Preliminary operations: Removal from valve			
74. Assemble hydraulic pump (3) with its support and tighten bolts (S) – if present 75. Install pipe (P)			
76. Use the hand pump to cycle the actuator and check the absence of leakages 77. Check the painted parts and, if necessary, paint according to painting cycle			

17. Part list

Centre body (cast iron) size 085

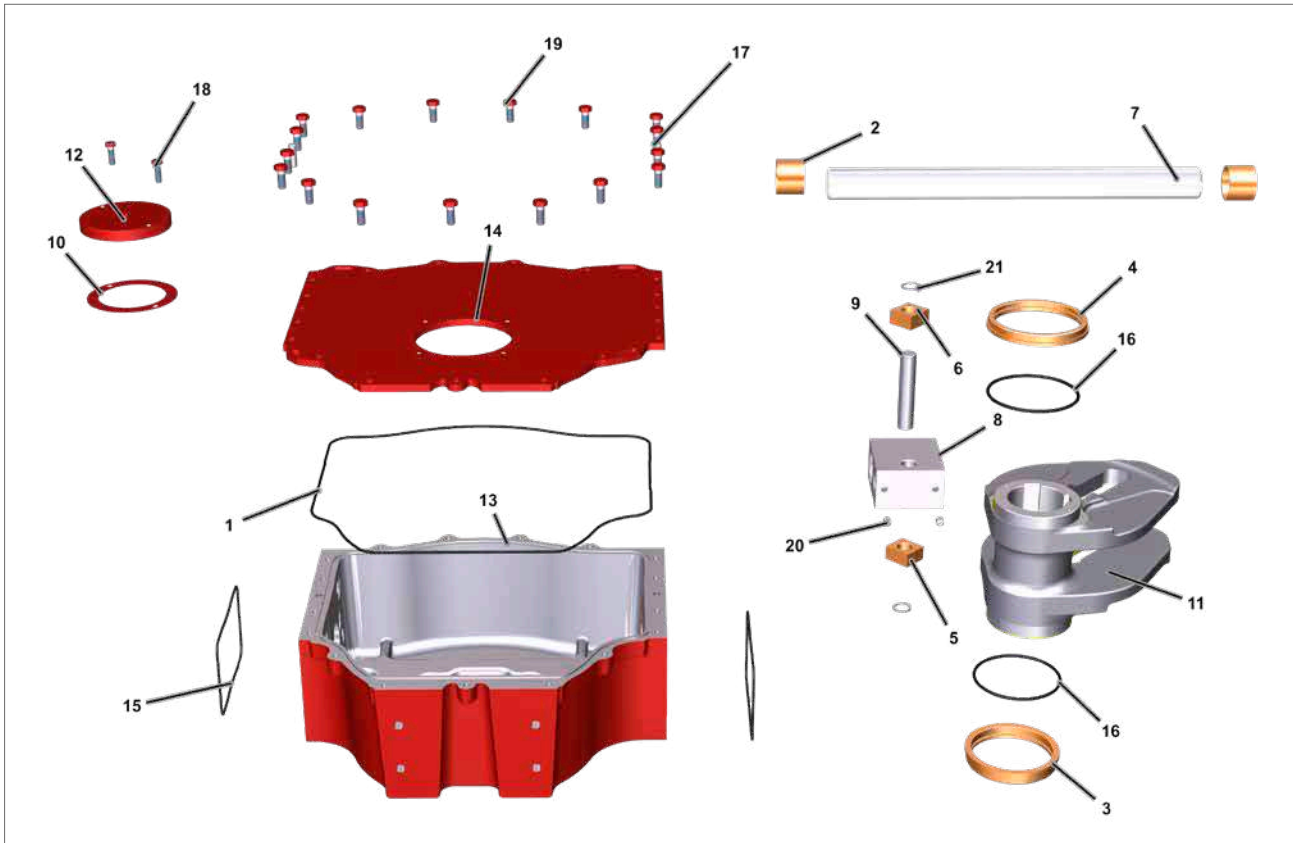

Fig 17.1 Centre body (cast iron) (actuator size 085)

ITEM	DESCRIPTION		QTY
1	O-ring	●	1
2	Guide bar bushing		2
3	Yoke bushing		1
4	Yoke bushing		1
5	Sliding block		1
6	Sliding block		1
7	Guide bar		1
8	Guide block		1
9	Yoke pin		1
10	Position indicator gasket	●	1
11	Scotch yoke		1
12	Position indicator		1
13	Housing		1
14	Cover		1
15	O-ring	●	2
16	O-ring	●	2
17	Parallel pin		2

ITEM	DESCRIPTION		QTY
18	Screw		2
19	Screw		17
20	Set screw		2
21	Circlip		2

● Recommended spare part

17. Part list

Centre body (cast iron) size 130

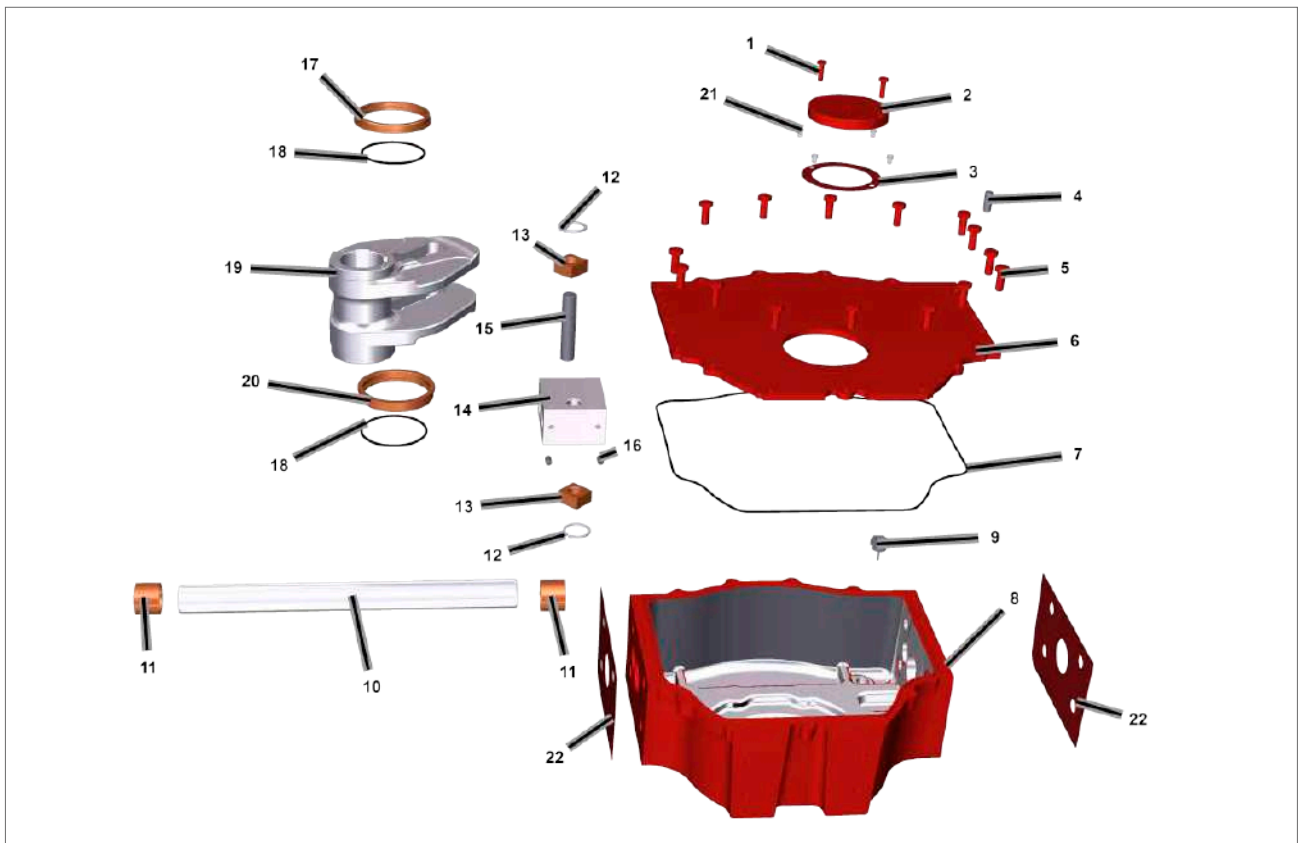

Fig 17.2 Centre body (cast iron) (actuator size 130)

ITEM	DESCRIPTION	QTY
1	Screw	2
2	Position indicator	1
3	Position indicator gasket	● 1
4	Parallel pin	2
5	Screw	15
6	Cover	1
7	O-ring	● 1
8	Housing	1
9	Safety valve	1
10	Guide bar	1
11	Guide bar bushing	2
12	Retaining ring	2
13	Sliding block	2
14	Guide block	1
15	Yoke pin	1
16	Set screw	2
17	Upper bushing	1

ITEM	DESCRIPTION	QTY
18	O-ring	● 2
19	Scotch yoke	1
20	Lower bushing	1
21	Screw	4
22	Gasket	● 2

● Recommended spare part

17. Part list

Centre body (welded) size 65-85-100-130-161-350

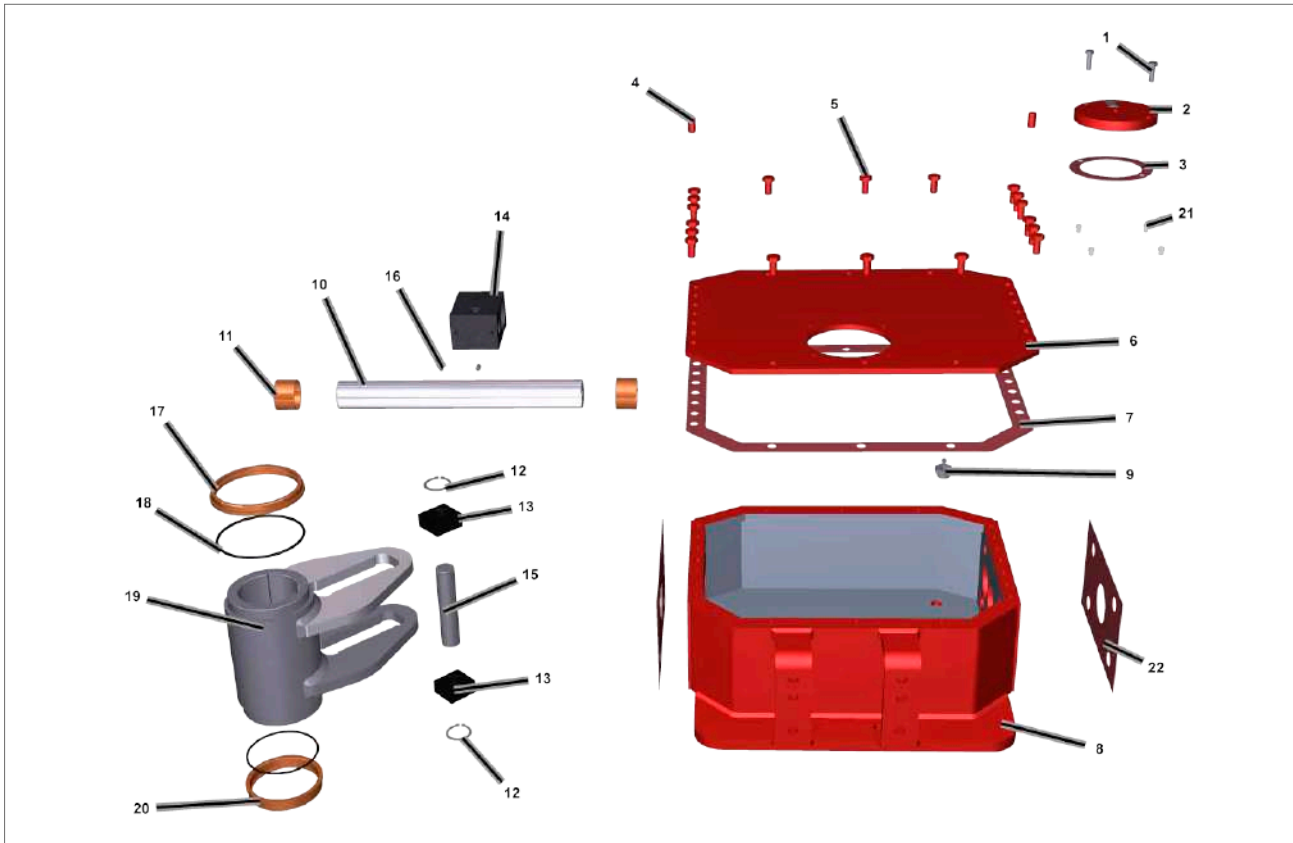

Fig 17.3 Centre body (welded) (actuator size 065, 85, 100, 130, 161, 350)

ITEM	DESCRIPTION	QTY
1	Screw	2
2	Position indicator	1
3	Position indicator gasket	● 1
4	Parallel pin	2
5	Screw	***
6	Cover	1
7	Cover gasket	● 1
8	Housing	1
9	Safety valve	1
10	Guide bar	1
11	Guide bar bushing	2
12	Circlip	2
13	Sliding block	2
14	Guide block	1
15	Yoke pin	1
16	Set screw	2
17	Upper bushing	1

ITEM	DESCRIPTION	QTY
18	O-ring	● 2
19	Scotch yoke	1
20	Lower bushing	1
21	Screw	4
22	Gasket	● 2

● Recommended spare part

(***) = number of screws per arm size

17. Part list

Centre body (cast iron) size 161

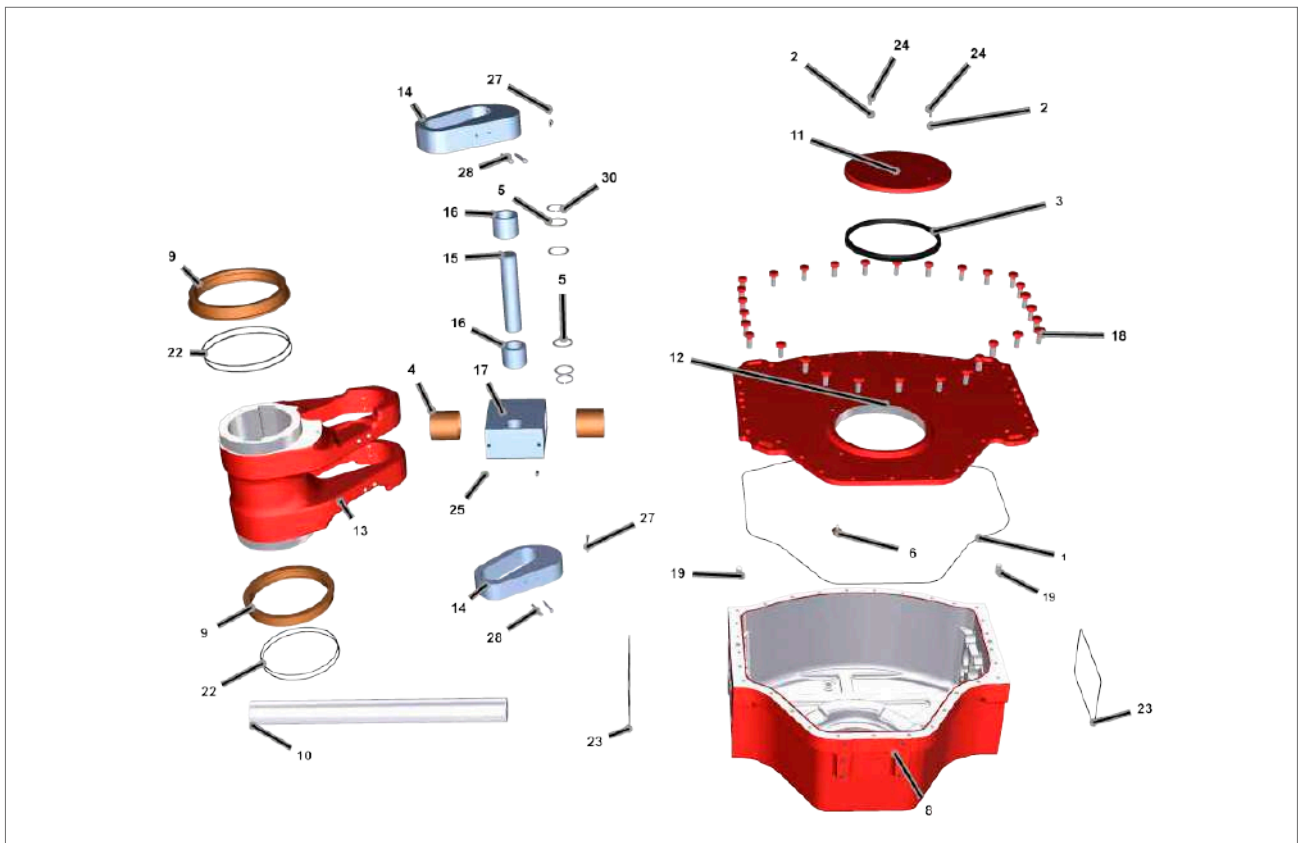

Fig 17.4 Centre body (cast iron) (actuator size 161)

ITEM	DESCRIPTION		QTY
1	O-ring	●	1
2	Washer		2
3	Position indicator seal	●	1
4	Guide bar bushing		2
5	Washer		4
6	Safety valve		1
8	Housing		1
9	Yoke bushing		2
10	Guide bar		1
11	Position indicator		1
12	Cover		1
13	Scotch yoke		1
14	Insert		2
15	Yoke pin		1
16	Bearing		2
17	Guide block		2

ITEM	DESCRIPTION		QTY
18	Screw		30
19	Parallel pin		2
22	O-ring	●	4
23	O-ring	●	2
24	Screw		2
25	Set screw		2
27	Screw		2
28	Screw		2
30	Circlip		2

● Recommended spare part

17. Part list

Centre body (welded) size 200-201-270-271

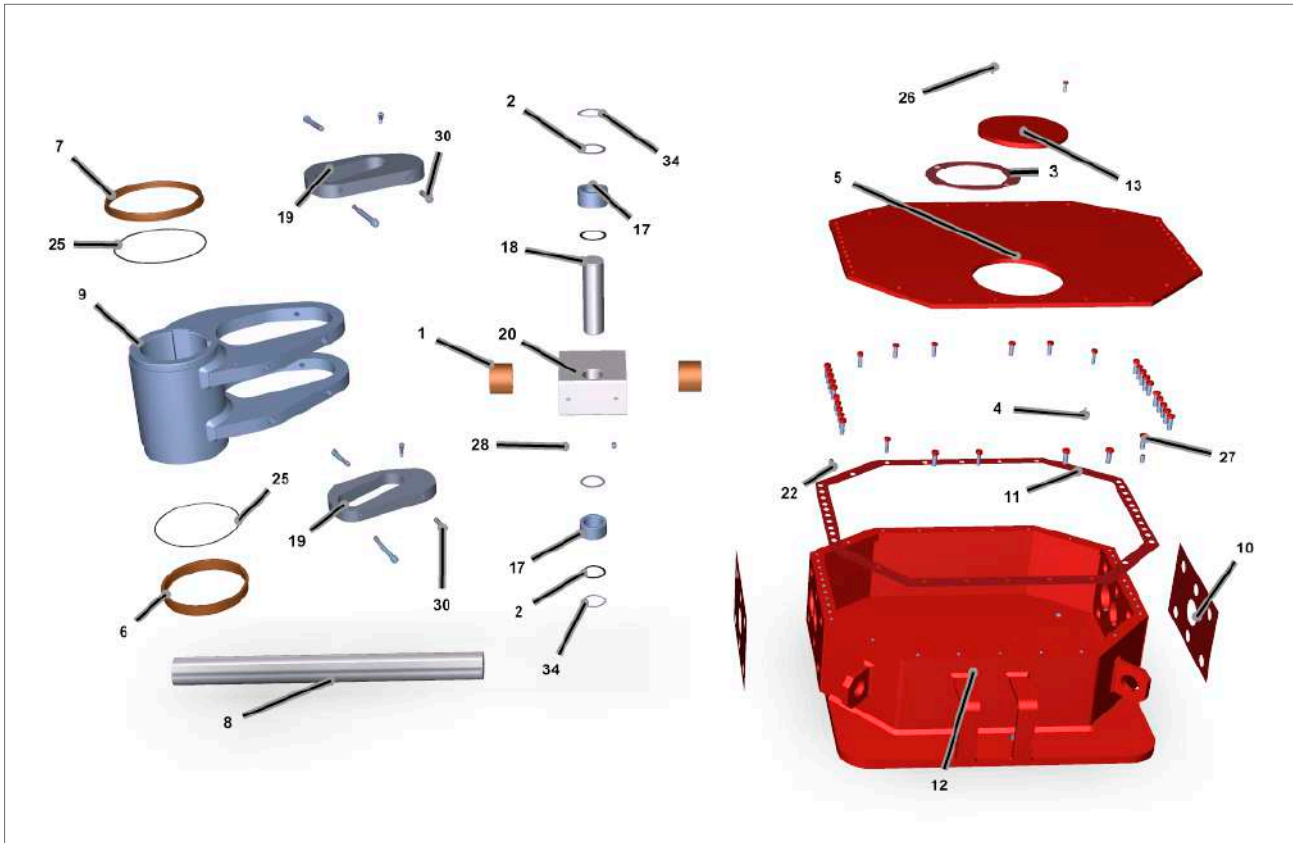

Fig 17.5 Centre body (welded) (actuator size 200, 201, 270, 271)

ITEM	DESCRIPTION	QTY
1	Guide bar bushing	2
2	Washer	2
3	Position indicator gasket ●	1
4	Safety valve	1
5	Cover	1
6	Lower bushing	1
7	Upper bushing	1
8	Guide bar	1
9	Yoke	1
10	Gasket ●	2
11	Cover gasket ●	1
12	Housing	1
13	Position indicator	1
17	Bearing	2

● Recommended spare part

(***) = number of screws per arm size

ITEM	DESCRIPTION	QTY
18	Yoke pin	1
19	Insert	2
20	Guide block	1
22	Parallel pin	2
25	O-ring ●	2
26	Screw	1
27	Screw	***
28	Set screw	2
30	Screw	2
34	Circlip	2

17. Part list

Spring container

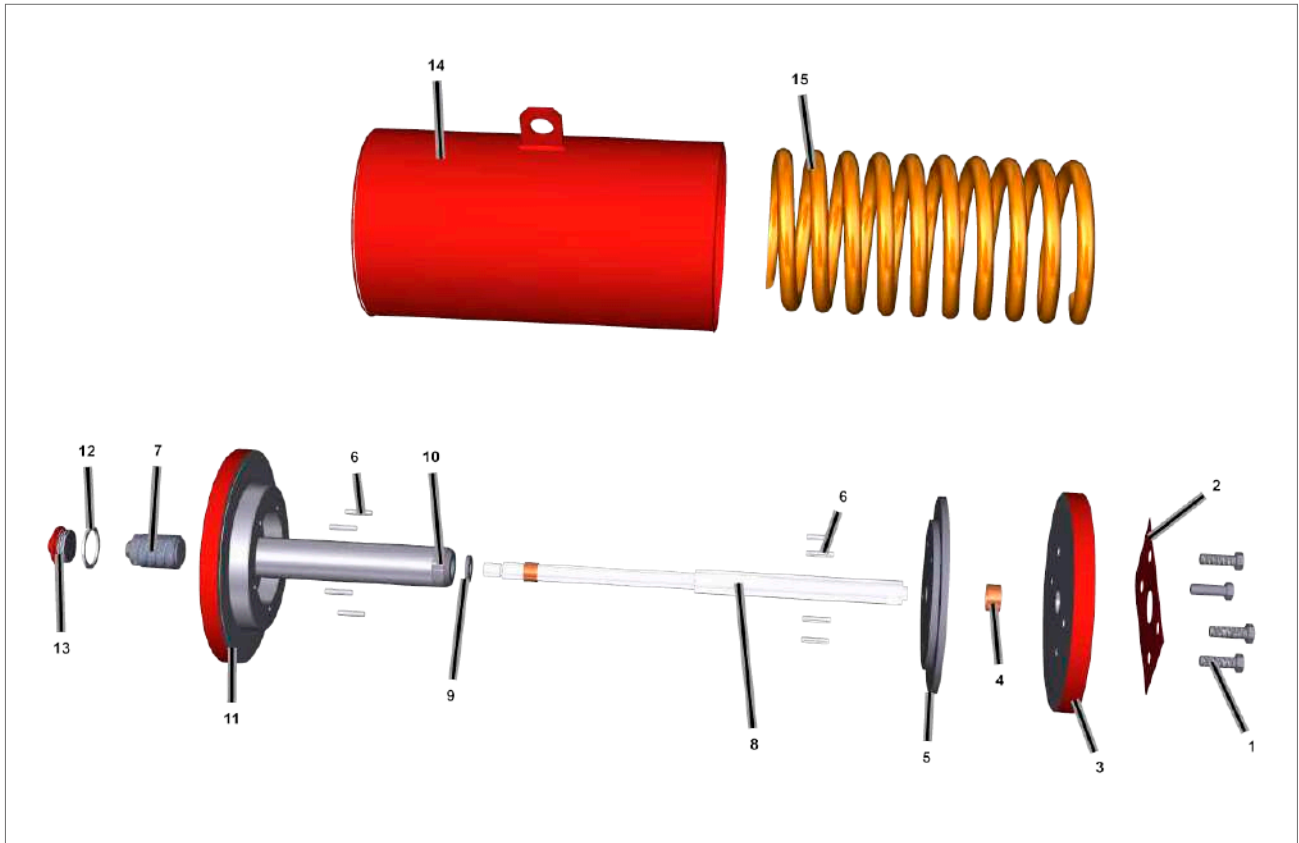

Fig 17.6 Spring container

ITEM	DESCRIPTION	QTY
1	Screw	*
2	Gasket	1
3	Head flange	1
4	Bushing	1
5	Spring driving flange	1
6	Elastic pin	8
7	Stop bolt	2
8	Rod	1
9	Washer	1
10	Nut	1
11	End flange	1
12	Seal washer/O-ring	● 2
13	Plug	1
14	Spring container	1
15	Spring	**

● Recommended spare part

(*) = Number of screws depending on size

(**) = Number of springs depending on size

17. Part list

Centre body closure flange

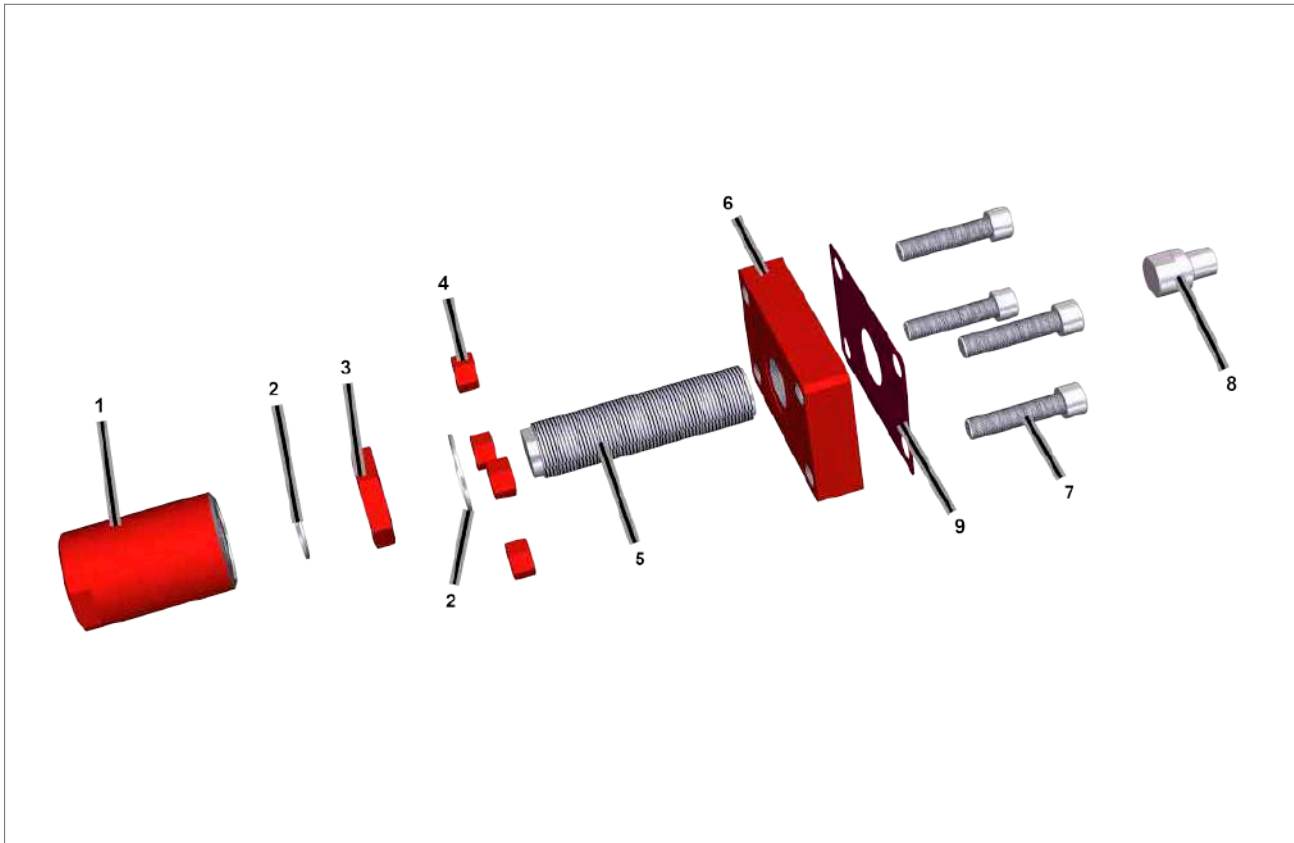

Fig 17.7 Centre body closure flange

ITEM	DESCRIPTION	QTY
1	Cap nut	1
2	Seal washer/O-ring	● 2
3	Stop nut	1
4	Nut	***
5	Stop bolt	1
6	Flange	1
7	Screw	***
8	Guide block plug	1
9	Gasket/O-ring	● 1

● Recommended spare part

(***) = Number and size of screw depending on arm size

17. Part list

Hydraulic cylinder

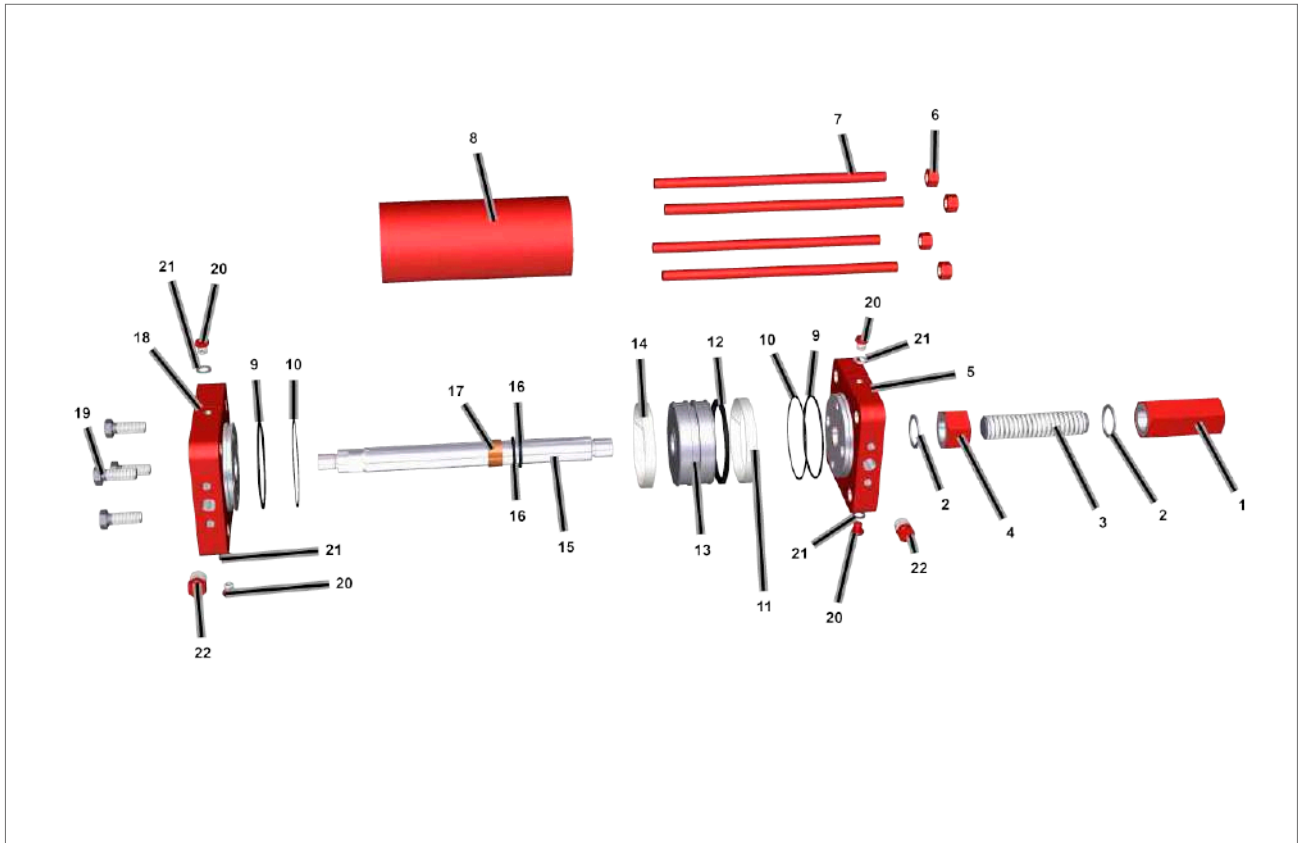

Fig 17.8 Hydraulic cylinder

ITEM	DESCRIPTION	QTY
1	Cap nut	1
2	Seal washer/O-ring	● 2
3	Stop bolt	1
4	Stop nut	1
5	End flange	1
6	Nut	**
7	Tie rod	**
9	O-ring	● 2
10	Back up ring	● 2
11	Sliding ring	● 1
12	Piston seal	● 1
13	Piston	1
14	Sliding ring	● 1
15	Piston rod	1

ITEM	DESCRIPTION	QTY
16	Piston rod seal	● 2
17	Bushing	1
18	Head flange	1
19	Screw	4
20	Plug	4
21	Washer	4
22	Plug	2

● Recommended spare part

(**) = Number of tie rods and nut depending on cylinder size

18. Grease and hydraulic oil specification

In general, there is no need to lubricate the actuator because its mechanism is lubricated for life. The standard grease specifications for Rotork scotch yoke actuators are shown below. If an alternative was specified and/or supplied, please refer to the job specific documentation.

18.1 Grease

Lubricate the mechanical sliding components of the scotch yoke actuators using the following grease or equivalent for temperature range -30 to +100 °C (-22 to +212 °F).

Manufacturer:	Dow Corning Corporation
Trade name: Colour:	MOLIKOTE® P40 Clear brown
Unworked penetration (ISO 2137): Viscosity of oil at 40 °C (104 °F) (DIN 51 562):	310-350 mm/10 360 mm ² /s
Service temperature: Drop point (ISO 2176):	-40 to 230 °C (-40 to 446 °F) None
Four ball tester Weld load (Din 51 350 pt.4) Wear scar under 800N load (Din 51 350 pt.5)	3000 N 0.94 mm
Coefficient of friction ^[1] Screw test - μ thread Screw test - μ head	0.16 0.08

1. Coefficient of friction in bolted connection, M12x1.75, 8.8, on blackened surface.

Lubricate mechanical sliding components of the scotch yoke actuators using the following grease or equivalent for temperature range -60 to +100 °C (-76 to +212 °F).

Manufacturer:	Mobil
Trade name:	MOBILTHEMP® SHC100™
NLGI grade:	2
Colour:	Clear brown
Penetration, density, viscosity Worked penetration at 25 °C (77 °F) (ASTM D 217): Viscosity of oil at 40 °C (104 °F) (ASTM D445):	280 100 CSt
Temperature Drop point (ASTM D 2265):	>260 °C (>500 °F)
Load-carrying capacity, wear protection, service life Four ball tester (ASTM D 2266) Weld load (ASTM D 2596) Corrosion protection (ASTM D6138)	0.4 mm >200 0

QUANTITY OF GREASE IN HOUSING	
Centre body size	Qty (kg)
065	0.3
085	0.3
100	0.3
130	0.4
161	0.5
200/201	0.5
270/271	0.8
350	1.2

18. Grease and hydraulic oil specification

18.2 Hydraulic oil

This is the standard oil specification for Rotork hydraulic manual override and hydraulic cylinders working at temperature between -20 to +100 °C (-4 to +212 °F) for EX and non-EX application.

Manufacturer:	MOBIL
Trade name:	DTE 10 EXCEL 32
ISO viscosity grade:	32
Viscosity, ASTM D 445 cSt @ 40 °C (104 °F) cSt @ 100 °C (212 °F)	32.7 6.63
Viscosity index, ASTM D 2270	164
Brookfield viscosity ASTM D 2983, cP @ -20 °C (-4 °F)	1090
Brookfield viscosity ASTM D 2983 cP @ -30 °C (-22 °F)	3360
Brookfield viscosity ASTM D 2983 cP @ -40 °C (-40 °F)	14240
Tapered roller bearing (CEC L-45-A-99), %viscosity loss	5
Density 15 °C (59 °F), ASTM D 4052, kg/L	0.8468
Copper strip corrosion, ASTM D 130, 3 hrs @ 100 °C (212 °F)	1B
Rust characteristics, ASTM D 665B	Pass
FZG gear test, DIN 51534, fail stage	12
Pour point, ASTM D 97	-54 °C (-65 °F)
Flash point, ASTM D 92	250 °C (482 °F)
Foam sequence I, II, III, ASTM D 892, ml	20/0
Dielectric strength, ASTM D877, kV	49
Acute aquatic toxicity (LC-50, OECD 203)	Pass

This is the standard oil specification for Rotork hydraulic manual override and hydraulic cylinders working at temperature between -40 to +100 °C (-40 to +212 °F) for EX and non-EX application.

Manufacturer:	MOBIL
Trade name:	DTE 10 EXCEL 15
ISO viscosity grade:	15
Viscosity, ASTM D 445 cSt @ 40 °C (104 °F) cSt @ 100 °C (212 °F)	15.8 4.07
Viscosity index, ASTM D 2270	158
Brookfield viscosity ASTM D 2983 cP @ -40 °C (-40 °F)	2620
Tapered roller bearing (CEC L-45-A-99), %viscosity loss	5
Density 15 °C (59 °F), ASTM D 4052, kg/L	0.8375
Copper strip corrosion, ASTM D 130, 3 hrs @ 100 °C (212 °F)	1B
Pour point, ASTM D 97	-54 °C (-65 °F)
Flash point, ASTM D 92	182 °C (360 °F)
Foam sequence I, II, III, ASTM D 892, ml	20/0
Dielectric strength, ASTM D877, kV	45
Acute aquatic toxicity (LC-50, OECD 203)	Pass

18. Grease and hydraulic oil specification

This is the standard oil specification for Rotork hydraulic manual override and hydraulic cylinders working at temperature down to -60 °C (-76 °F) for non-EX applications.

Manufacturer:	MOBIL
Trade name:	UNIVIS HVI
ISO viscosity grade:	32
Viscosity, ASTM D 445 cSt @ 40 °C (104 °F) cSt @ 100 °C (212 °F)	13.5 5.3
Viscosity index, ASTM D 2270	404
Kinematic viscosity @ -40 °C (-40 °F), ASTM D 445	371 cST
Copper strip corrosion, ASTM D 130	1A
Pour point, ASTM D 97	-60 °C (-76 °F)
Flash point, ASTM D 92	101 °C (214 °F)

This is the standard oil specification for Rotork hydraulic manual override and hydraulic cylinders working at temperature range -60 to +90 °C (-76 to +194 °F) for EX application.

Manufacturer:	TECCEM
Trade name:	SynTop 1003 FG
ISO viscosity grade:	3
Viscosity, ASTM D 445 cSt @ -40 °C (-40 °F) cSt @ -55 °C (-67 °F) cSt @ 40 °C (104 °F)	73 2.6 3.2
Pour point, ASTM D 97	-88 °C (-126 °F)
Flash point, ASTM D 92	140 °C (284 °F)
Density 20 °C (68 °F), kg/L	0.86

An alternative oil may have been specified for your application. Please refer to the job specific documentation.

rotork®



www.rotork.com

A full listing of our worldwide sales and service network is available on our website.

Rotork plc
Brassmill Lane, Bath, UK
tel +44 (0)1225 733200
email mail@rotork.com

PUB011-007-00
Issue 09/24

All Rotork actuators are manufactured under a third party accredited ISO9001 quality assurance programme. As we are continually developing our products, their design is subject to change without notice.

The name Rotork is a registered trademark. Rotork recognises all registered trademarks.
Published and produced in the UK by Rotork. POLTG0924